

List of pages in this Trip Kit

Trip Kit Index

Airport Information For VTBS

Terminal Charts For VTBS

Revision Letter For Cycle 07-2023

Change Notices

Notebook

General Information

Location: BANGKOK THA
ICAO/IATA: VTBS / BKK
Lat/Long: N13° 41.15', E100° 44.93'
Elevation: 5 ft

Airport Use: Public
Daylight Savings: Not Observed
UTC Conversion: -7:00 = UTC
Magnetic Variation: 0.6° W

Fuel Types: Jet A-1
Customs: Yes
Airport Type: IFR
Landing Fee: Yes
Control Tower: Yes
Jet Start Unit: No
LLWS Alert: Yes
Beacon: Yes

Sunrise: 2304 Z
Sunset: 1130 Z

Runway Information

Runway: 01L
Length x Width: 12139 ft x 197 ft
Surface Type: asphalt
TDZ-Elev: 5 ft
Lighting: Edge, ALS, Centerline, TDZ

Runway: 01R
Length x Width: 13123 ft x 197 ft
Surface Type: asphalt
TDZ-Elev: 5 ft
Lighting: Edge, ALS, Centerline, TDZ

Runway: 19L
Length x Width: 13123 ft x 197 ft
Surface Type: asphalt
TDZ-Elev: 5 ft
Lighting: Edge, ALS, Centerline, TDZ

Runway: 19R

Length x Width: 12139 ft x 197 ft
Surface Type: asphalt
TDZ-Elev: 5 ft
Lighting: Edge, ALS, Centerline, TDZ

Communication Information

ATIS: 127.650 Departure Service
ATIS: 133.600 Arrival Service
Suvarnabhumi Tower: 119.000
Suvarnabhumi Tower: 118.200
Suvarnabhumi Ground: 121.650
Suvarnabhumi Ground: 121.750
Suvarnabhumi Ground: 121.950
Suvarnabhumi Clearance Delivery: 133.800
Suvarnabhumi Clearance Delivery: 128.700
Bangkok Approach: 120.300
Bangkok Approach: 128.950
Bangkok Approach: 124.350
Bangkok Approach: 125.800
Bangkok Approach: 119.100
Bangkok Approach: 122.350
Bangkok Approach: 125.200
Suvarnabhumi Arrival: 126.300
Suvarnabhumi Arrival: 121.100
Suvarnabhumi Departure: 119.250

VTBS/BKK

SUARNABHUMI INTL



15 APR 22

20-1P

.Eff.21.Apr.

BANGKOK, THAILAND

AIRPORT BRIEFING

1. GENERAL

1.1. ATIS

Arrival D-ATIS 133.6 Departure D-ATIS 127.65

1.2. LOW VISIBILITY PROCEDURES (LVP)

1.2.1. GENERAL

- Low visibility procedures will be established for operation in a visibility of less than RVR 550 m or a cloud base of less than 200 ft.
- Special ATC procedures and safeguarding will be applied during CAT II operations to protect ACFT operating in low visibility and to avoid interference to the ILS signals in accordance with ICAO Doc 9365: Manual of all-weather operations. Pilots will be informed when these procedures are in operation by ATIS or RTF.
- Runway 19L/01R and runway 19R/01L, subject to serviceability of the required facilities, are suitable for CAT II operations by operators whose minima have been accepted by the Department of Civil Aviation (DCA).

1.2.2. ARRIVAL

- CAT II Approach and Landing: Pilots who wish to carry out an ILS CAT II approach shall inform Bangkok Approach on initial contact.
- Pilots may carry out a practice ILS CAT II approach at any time. But the full safeguarding procedures will not be applied and pilots should anticipate the possibility of ILS signal interference.
- When Low Visibility Procedures are in operation, a much reduced landing rate can be expected due to the requirement for increased spacing between arriving ACFT.
- ACFT will be vectored to intercept the ILS localizer at least 10 NM from touchdown.
- All runway exits are equipped with green/yellow coded taxiway center line lights to indicate the boundary of the localizer sensitive area.
- Pilots are required to make a "RUNWAY VACATED" call giving due allowance for the size of the ACFT to ensure that the entire ACFT has vacated the localizer sensitive area.
- ACFT shall vacate the runway via the first convenient exit taxiways which are designated as follows:
 - Runway 19L via B8, B10, B11, B12, B13
 - Runway 01R via B7, B5, B3, B2, B1
 - Runway 19R via E9, E13, E15, E19, E21
 - Runway 01L via E12, E7, E5, E2, E1
- Pilots not able to comply with these requirements should notify ATC immediately.

1.2.3. DEPARTURE

- ATC will require departing ACFT to use the CAT II holding positions listed below:
 - Runway 19L: B1, B2
 - Runway 01R: B13, B12
 - Runway 19R: E1, E2
 - Runway 01L: E21, E19
- Except as described above, other intersection take-offs are not permitted.
- Pilots wishing to conduct an ILS guided take-off shall inform ATC on start up in order to ensure that the protection of the localizer sensitive area is provided.

1.2.4. TAXIING ACFT

- Taxiing ACFT must follow the lighted taxiway center line in relation to the standard taxi route provided by ATC. Deviation from the standard taxi route may be approved for traffic reasons.
- When low visibility operating procedures are in operation pilots-in-command shall adjust ACFT taxiing speeds to ensure that they are able to comply with ATC instructions.

1.2.5. TOWING OF ACFT

- ACFT towing will be restricted when the RVR is less than 550m.

VTBS/BKK
SUVARNABHUMI INTL

 15 APR 22
Eff. 21. Apr. 20-1P1

BANGKOK, THAILAND
AIRPORT BRIEFING

1. GENERAL

1.2.6. ACFT GUIDANCE UNDER ALL-WEATHER OPERATIONS CATEGORY II

- Taxiway center line lights.
- As soon as the operation of Category II low visibility procedures is announced, ACFT will only be permitted to taxi on taxiways with operating center line lights.
- Taxiway center line lights within the ILS sensitive area are color-coded (Green/Yellow) from runway 19L/01R to taxiway B and from runway 19R/01L to taxiway E. To indicate that the ACFT has vacated the ILS sensitive area, pilots are to delay the call "RUNWAY VACATED" until the ACFT has completely passed the end of the Green/Yellow color-coded taxiway center line lights.

1.2.7. STOP BARS

- Taxiing across stop bars is strictly prohibited as long as they are in operation. No kind of clearance includes permission to taxi across a stop bar in operation.
- Stop bar is provided to assist in preventing inadvertent incursions of aircraft and vehicles onto the runway.
- Stop bars are installed at following locations:
 - Taxiway B1, B2, B3, B11, B12, B13
 - Taxiway E1, E2, E5, E15, E19, E21

1.2.8. NO-ENTRY BAR

- No-entry bar is provided across a taxiway which is intended to be used as an exit only taxiway to assist in preventing inadvertent access of traffic to that taxiway.
- No-entry bar is provided to prevent traffic from entering the taxiway in the wrong direction.
- No-entry bars are installed at following locations:
 - Taxiway B5, B7, B8, B10
 - Taxiway E7, E9, E12, E13

1.2.9. INTERMEDIATE HOLDING POSITION LIGHTS

- Taxiing across intermediate holding position lights is allowed.
- Intermediate holding position lights are installed at some intermediate holding position.
- Intermediate holding position lights consist of three fixed unidirectional lights showing yellow in the direction of approach to intermediate holding position.

1.2.10. ADVERSE WEATHER WARNING

- Aircraft will not be refused permission to land or take off at Suvarnabhumi International airport solely because of adverse weather conditions. The pilot-in-command of a commercial air transport aircraft shall be responsible for operation in accordance with applicable company weather minima.

1.3. ADVERSE WEATHER CONDITION & PROCEDURES

Adverse Weather Condition Warning at Suvarnabhumi International airport:

Adverse weather condition that causes thunderstorms and/or strong wind and even lightning may endanger airside operation to a large extent. Therefore, when it is predicted to occur, the effective warning system shall be deployed for

airside workers and vehicle operators. The objective of this warning is to elaborate how the situations of each phase are and to alert all the airside personnel to work more carefully and safely in the airfield. Adverse Weather Condition Warning at Suvarnabhumi International airport can be defined into 3 levels;

Level 1 Thunderstorms Observations Reporting: The report is used when thunderstorms are detected within 50 kilometers from Aerodrome Reference Point (ARP) and their directions are heading Suvarnabhumi International airport.

Level 2 Thunderstorms and/or Strong Wind Warning: This warning is used when thunderstorms and/or strong wind are more than 25 knots within 16 kilometers from Aerodrome Reference Point (ARP) and their directions are towards or over Suvarnabhumi International airport.

Level 3 Lightning Warning: The warning is employed when thunderstorms are over Suvarnabhumi International airport and lightning characteristic is obviously detected.

1.3.1. LEVEL 1: THUNDERSTORMS OBSERVATION REPORTING

- Suvarnabhumi International airport will notify all concerned units by announcing "Thunderstorms Warning" when adverse weather condition level 1 takes place.

VTBS/BKK

SUARNABHUMI INTL



BANGKOK, THAILAND

AIRPORT BRIEFING

1. GENERAL

1.3.1. Level 1: Thunderstorms Observation Reporting (Cont):

The details how the announcement is made has already distributed to the operators concerned by means of official letter.

-When the condition of adverse weather condition level 1 terminates, Suvarnabhumi International airport will announce "Thunderstorms Warning Terminated".

Airlines, Ground Service Providers, and Airside Operator's Procedures

When receive the adverse weather condition level 1;

-Report the situation to their staff.

- Operate with carefulness, be alert of the aircraft and vehicle' safety and tightly secure all ground service equipments.

1.3.2. Level 2: Thunderstorms and/or strong wind warning

- When thunderstorms and/or strong wind are more than 25 knots within 16 kilometers from Aerodrome Reference Point (ARP) and their direction are towards or over the aerodrome, Suvarnabhumi International airport will notify all concerned units by announcing "Thunderstorms and Strong Wind Warning".

- And when receive the cancellation of adverse weather condition, Suvarnabhumi International airport will announce as "Thunderstorms and Strong Wind Warning Terminated".

Airlines, Ground Service providers, and Airside Operator's Procedures

When receive the adverse weather condition level 2;

- Report the situation to their staff.

- Remove the stair from the aircraft and tie the gantry securely to the ground and also close the front part of stair.

- Ensure aircraft parking brake is applied during on the parking stand.

- Ensure aerobridge is parked on the assigned markings and close the front part of it.

- Bond the aircraft ground receptacle.

- Ensure that light aircraft are parked facing head wind and secured to the ground.

1.3.3. Level 3: Lightning warning

- When thunderstorms are over Suvarnabhumi International airport and may likely cause lightning, Suvarnabhumi International airport will notify all concerned units by announcing "Lightning Warning" and instantly turn on the red warning light and siren.

- And when receive the cancellation of adverse weather condition, turn off the red warning light and siren and announce as "Lightning Warning Terminated".

Suvarnabhumi Air Traffic Control Center's Procedures

When receive the adverse weather condition warning level 3 from Airside Operations Control Center (AOCC), keep monitoring the situation and inform Flight Operation of the airlines concerned about the adverse weather condition warning level 3 at Suvarnabhumi International airport and/or announce through Automatic Terminal Information Service (ATIS).

Airlines, Ground Service providers, and Airside Operator's Procedures

When receive the adverse weather condition level 3;

- Restrain from operating and stay in the nearby buildings, or vehicles, or lightning shelters, or high mass light poles within 22.60 meters, or under aircraft with ground receptacle bonded and monitor the weather conditions outside periodically.

- Avoid contacting or staying near the aircraft without ground receptacle connected.

- When receive the lightning warning while being outside the building, do not lie down on the floor. Do sit on feet together with knees up in order to least contact with the ground and decrease the overall body height which might induce electricity through the body from the lightning currents.

- Refrain from refueling the aircraft.

- Airlines informs ground service providers the adverse weather condition warning level 3 and recommend them the temporary suspension of ground operations and cease the communication with pilot.

Arrival Aircraft

- Aircraft designated to park at parking bay with Visual Docking Guidance System: VDGS;
1.) While the aircraft is approaching to the parking bay, the License Mechanic who is responsible for aircraft conveyance shall monitor the aircraft movement in order to make sure the moving aircraft is safe. This should be done while he/she is in the safe area.

VTBS/BKK

SUARNABHUMI INTL



BANGKOK, THAILAND

AIRPORT BRIEFING

1. GENERAL

1.3.3. Level 3: Lightning warning (Cont):

- 2.) When the aircraft reaches the parking bay and is in the right position of stand markings, the License Mechanic shall coordinate with pilots to apply parking brake and bond the aircraft's nose gear and aircraft ground receptacle. Also, wait for the cancellation of adverse weather condition warning from Suvarnabhumi International airport. Then, the operations could be done as normal.
- Aircraft arranged to park at parking bay without Visual Docking Guidance System: VDGS;
 - 1.) Airlines and ground service providers must provide the License Mechanic who is responsible for aircraft conveyance to perform as Marshaller leading the aircraft to its parking bay.
 - 2.) When the aircraft reaches the parking bay and is in the right position of stand markings, the License Mechanic shall coordinate with pilots to apply parking brake and bond the aircraft's nose gear and aircraft ground receptacle. And also, wait for the cancellation of adverse weather condition warning from Suvarnabhumi International airport. Then, the operations should be done as normal.

Departure Aircraft

Departure aircraft operating at parking bay should be done as follows;

- 1.) While the aircraft is being pushed back from parking bay and/or being on the taxiway ready to take off with all engines started, operate a normal procedures until they are completed and the aircraft has taken off.
- 2.) In case the aircraft is being pushed back but the engine is not started yet. If the ground service providers consider bringing the aircraft back to its parking bay and wait for the cancellation of adverse weather condition warning from Suvarnabhumi International airport, airline or ground service providers must inform AOCC of that decision. This is because the airport is needed to rearrange the parking bay for another arriving aircraft.
- 3.) For the aircraft in no.2 which arranged to park at the Contact Gate that has passenger loading bridges, while waiting for the adverse weather condition warning to be cancelled and airline or ground service provider considers that the aircraft bridge is needed again, inform the Airside Operations Control Center (AOCC) accordingly. Also, follow the procedures for facility request from Suvarnabhumi International airport properly.

Suspending the operations of airlines and/or ground service providers is conducted solely for the sake of safety of all operators which was mutually decided between airline members/ ground service providers and the airport operator. Therefore, in case of flight delays, airlines and ground service providers shall not claim any compensation from Suvarnabhumi International airport or concerned units.

1.4. GROUND MOVEMENT

1.4.1. TAXI PROCEDURES

- All surface movement of aircraft, vehicles and personnel on the maneuvering area is subject to prior permission from ATC.
- Within the movement area, pilots will be cleared to and from the aircraft stands under general direction from Ground Control. Pilots are reminded of the extreme importance of maintaining a careful look out at all times.
- Directions issued by ATC should be followed specifically. RTF transmissions must be brief, concise and kept to the minimum number.

1.4.2. OPERATION OF MODE S TRANSPONDERS ON THE GROUND

- Suvarnabhumi International Airport is equipped with an Advanced Surface Movement Radar utilizing mode S multilateration. Aircraft operators intending to use Suvarnabhumi International Airport should ensure that mode S transponders are able to operate when the aircraft is on the ground.
- For aircraft that are capable of reporting aircraft identification (i.e. call signs used in flight) the aircraft identification should also be entered via FMS or control panel. The ICAO defined format for aircraft identification (i.e. same format as used in ICAO plan e.g. THA640, CPA701, SIA068) shall be used.

VTBS/BKK

JEPPESSEN

BANGKOK, THAILAND

SUARNABHUMI INTL

22 JAN 21 (20-1P4) .Eff.28.Jan.

AIRPORT BRIEFING

1. GENERAL

1.4.2. OPERATION OF MODE S TRANSPONDERS ON THE GROUND (CONT)

- Flight crew should select XPDR or the equivalent according to specific installation. It must also be ensured that the transponder is operating (i.e. OUT OF STAND-BY or OFF POSITION) and the assigned mode A code is selected in accordance with the following:
 - a) for a departing flight, upon received airway clearance; except that subject to allocated wheels up time (AWUT) or departure time restrictions, the action should be done when starting up engine.
 - b) for an arriving flight, continuously until the aircraft is fully parked at the stand.
- To prevent possible interference to radar surveillance systems, TCAS should be functioned;
 - a) for departure, when ACFT are entering the runway or line up clearance is received;
 - b) for arrival, until ACFT have vacated the runway.
- While on the ground, pilots of ACFT not equipped with mode S transponder shall operate the transponder and select mode A code as individually directed by the ATC unit:
 - a) for departure, when starting up engine;
 - b) for arrival, until ACFT have completely parked.

1.4.3. TRACKING AND IDENTIFICATION OF AIRPORT SURFACE VEHICLES

- To provide tracking and identification of authorized movements, any authorized vehicle intended to be used on the maneuvering area at Suvarnabhumi International Airport shall be equipped with mode S squitter box to inform mode S multilateration system of its position.

1.5. RADIO COMMUNICATION FAILURE PROCEDURE

1.5.1. GENERAL

- Radio communication is considered to be failed, if during two minutes that the pilot or the ATC unit does not answer the repeated calls through all available communication channels.
- The transponder is set to be Mode A code 7600 as soon as the pilot has detected communication failure.
- The pilot shall use all available facilities to re-establish communication with ATC unit directly or by means of the other aircraft. If necessary, the emergency frequency 121.5 MHz may be used.
- In any case of radio communication failure, the pilot shall continue listening on the appropriate radio frequency and transmitting the position reports, actions and flight conditions. The pilot shall comply with one of the following procedures: ARRIVAL paragraph 2.2., DEPARTURE paragraph 3.3. below.

1.6. AIRCRAFT TRANSPONDER FAILURE PROCEDURES

1.6.1. CONTROL OF AIRCRAFT EXPERIENCING TRANSPONDER FAILURE PROCEDURE

- When a transponder failure is detected to be unserviceable prior to departure, ATC shall confirm with the pilot of his transponder operations using the following phraseologies.

Phraseologies

- 'C/S, CONFIRM TRANSPONDER ON', or
- 'C/S, CHECK YOUR TRANSPONDER OPERATED NORMALLY', or
- 'C/S, TRANSPONDER NOT RECEIVED, CHECK FUNCTIONALITY'

When it has been confirmed that aircraft transponder fails, ATC shall advise the pilot to repair it before departure. However, the surface radar blind spot, where the transponder might not be easily detected, should be taken into consideration.

Phraseologies

- 'C/S, ADVISE TRANSPONDER REPAIRED BEFORE DEPARTURE', or
- 'C/S, ADVISE RETURN TO BAY FOR TRANSPONDER REPAIRING'

VTBS/BKK

JEPPESSEN

22 JAN 21 (20-1P5) .Eff.28.Jan.

BANGKOK, THAILAND

SUARNABHUMI INTL

AIRPORT BRIEFING

1. GENERAL

1.6.1. CONTROL OF AIRCRAFT EXPERIENCING TRANSPONDER FAILURE PROCEDURE (CONT)

- When transponder appears to be unserviceable after the aircraft is airborne, ATC must inform the pilot of his transponder failure using the following phraseologies.

Phraseologies

'C/S, CONFIRM TRANSPONDER ON', or

'C/S, CHECK YOUR TRANSPONDER OPERATED NORMALLY', or

'C/S, TRANSPONDER NOT RECEIVED, CHECK FUNCTIONALITY'

When it has been confirmed that the aircraft transponder fails, ATC shall advise the pilot to return to his departure airport as well as relay all necessary information to Aerodrome Control Tower and all concerned units.

Phraseologies

'C/S, ADVISE RETURN TO LAND AT (DEPARTURE AERODROME) FOR TRANSPONDER REPAIRING, REQUEST YOUR INTENTION',

'C/S, ADVISE RETURN TO BAY FOR TRANSPONDER REPAIRING'

In case pilot decide to proceed to first intended landing or nearest suitable aerodrome, primary radar separation shall be provided. However, the pilot shall be reminded that delays can be expected and some requests might not be granted e.g. route to be flown, cruising altitude/level.

1.6.2. CONTROL OF AIRCRAFT OVERFLYING BANGKOK FIR OR AIRCRAFT INTENDING TO LAND AT SUARNABHUMI INTERNATIONAL AIRPORT WITH ITS FAILED TRANSPONDER PROCEDURE

- ATC must immediately inform the pilot of his transponder failure so that he could check its operations and repair it.
- ATC shall control, according to the filed flight plan, the aircraft experiencing transponder failure to land safely at Suvarnabhumi International Airport.
- ATC shall control, according to the filed flight plan, the over-fly aircraft experiencing transponder failure to land safely at the destination aerodrome.
- Approach Control shall coordinate closely with Suvarnabhumi Tower and/or other concerned units regarding the problem.
- The above procedures shall be applied to all aircraft except state aircraft and military aircraft.
- Aircraft intending to land at Suvarnabhumi International Airport with its failed transponder might be assigned to fly along an RNAV STAR and controlled solely by Suvarnabhumi PSR which normally covers up to 80NM.

1.7. LOCAL TRAFFIC REGULATIONS

1.7.1. AIRPORT REGULATIONS

- Suvarnabhumi Aerodrome Traffic Zone (ATZ) airspace is classified as class C.
- IFR and authorized VFR flights only are permitted, all flights are subject to air traffic control service and separated from each other.
- For air traffic management and effective traffic flow, runway 01L and 19L shall be mainly used for departure while Runway 01R and 19R shall be used for arrival. The use of runways different from this requirement may be possible as considered necessary under special circumstances, such as adverse weather conditions or operational necessity. In normal situations, only when traffic permits, ATC may initiate pilots to depart or land on the appropriate runway.
- To retain the defined value of runway capacity at Suvarnabhumi International Airport, and to provide efficient separation between ACFT for the safety of flight and orderly flow of air traffic, only ACFT category B or above with the minimum final approach speed of 110 kt. are permitted to use Suvarnabhumi International Airport. However, other ACFT may be authorized to operate within Suvarnabhumi ATZ if:
 - The ACFT is being used for or in connection with:

VTBS/BKK

JEPPESSEN

BANGKOK, THAILAND

SUVARNABHUMI INTL

22 JAN 21

20-1P6

.Eff.28.Jan.

AIRPORT BRIEFING

1. GENERAL

1.7.1. AIRPORT REGULATIONS (CONT)

- a) a search and rescue operation;
- b) a medical emergency; or
- c) a flight inspection of air navigation facilities.
- The pilot of the ACFT has declared an in-flight emergency.
- The ACFT constitutes VIP flight.
- The ACFT is as may be determined by the appropriate authority.
- The following school and training flights are not permitted:
 - a) school and training flights;
 - b) continuous take-off and landing exercises;
 - c) solo flight during basic flight training.

1.8. FUEL DUMPING PROCEDURE AND IN-FLIGHT MANAGEMENT PROCEDURES

1.8.1. INTRODUCTION

An aircraft in emergency or other urgent situations may need to dump fuel so as to reduce to maximum landing mass in order to affect a safe landing.

1.8.2. FUEL DUMPING AREAS

- North fuel dumping area: between R-335 and R-355, distance of 30 to 50 NM from BKK VOR, altitude at or above 8500'.
- East fuel dumping area: between R-090 and R-110, distance of 30 to 50 NM from BKK VOR, altitude at or above 8500'.
- South fuel dumping area: between R-190 and R-210, distance of 30 to 50 NM from BKK VOR, altitude at or above 8500'.

1.8.3. IN-FLIGHT FUEL MANAGEMENT PROCEDURES

- Definition

Minimum fuel: The term used to describe a situation in which an aircraft's fuel supply has reached a state where the flight is committed to land at a specific aerodrome and no additional delay can be accepted.

Mayday fuel: Describes the nature of the distress conditions when the calculated usable fuel predicted to be available upon landing at the nearest aerodrome where a safe landing can be made is less than the planned final reserve fuel.

- Actions taken by pilot

- The pilot-in-command shall continually ensure that the amount of usable fuel remaining on board is not less than the fuel required to proceed to an aerodrome where a safe landing can be made with the planned final reserve fuel remaining upon landing.
- The pilot-in-command shall request delay information from ATC when unanticipated circumstances may result in landing at the destination aerodrome with less than the final reserve fuel plus the fuel required either to proceed to an alternate aerodrome or the fuel required to operate to an isolated aerodrome.
- The pilot-in-command shall advise ATC of a minimum fuel state by declaring 'MINIMUM FUEL' when, having committed to land at a specific aerodrome, the pilot calculates that any changes to the existing clearance to that aerodrome may result in landing with less than planned final reserve fuel.

Note 1: The declaration of 'MINIMUM FUEL' informs ATC that all planned aerodrome options have been reduced to a specific aerodrome of intended landing and any changes to the existing clearance may result in landing with less than planned final reserve fuel. This is not an emergency situation but an indication that an emergency situation is possible should any additional delays occur.

Note 2: It should be noted that Pilots should not expect any form of priority handling as a result of a 'MINIMUM FUEL' declaration. ATC will, however, advise the flight crew of any additional expected delays as well as coordinate when transferring control of the aircraft to ensure that other ATC units are aware of the flight's fuel state.

VTBS/BKK

 JEPPESEN

BANGKOK, THAILAND

SUVARNABHUMI INTL

22 JAN 21 (20-1P7) .Eff.28.Jan.

AIRPORT BRIEFING

1. GENERAL

1.8.3. IN-FLIGHT FUEL MANAGEMENT PROCEDURES (CONT)

- The pilot-in-command shall declare a situation of distress related to the amount of fuel available on board the aircraft by broadcasting 'MAYDAY, MAYDAY, MAYDAY, FUEL' when the calculated usable fuel predicted to be available upon landing at the nearest aerodrome where a safe landing can be made is less than the planned final reserve fuel.
- Actions taken by ATC
 - When a pilot reports a state of 'MINIMUM FUEL', ATC shall respond to the pilot who indicates or suggests that he is becoming short of fuel or who has declared 'MINIMUM FUEL' as follows:
 - Inform the pilot of either:
 - a. The estimated delay, if pilots are en-route to, joining or are established in holding point such as IAWPs; or
 - b. The estimated track mileage, if pilots are being vectored to an instrument approach; or
 - Coordinate when transferring control of the aircraft to ensure other ATC units to be aware of the flight's fuel state.
 - Standard phraseology
 - Pilot transmission: (C/S), MINIMUM FUEL
 - Controller transmission: (C/S), ROGER [NO DELAY EXPECTED or EXPECT (delay information)]
- When a pilot reports a state of 'MAYDAY, MAYDAY, MAYDAY FUEL', this is an emergency and the aircraft shall be given priority over other traffic in the landing sequence. The aircraft will be committed to a landing, as in the event of any delay or a go-around, there may be insufficient fuel remaining for a safe landing.
 - Standard phraseology
 - Pilot transmission: (C/S) MAYDAY, MAYDAY, MAYDAY FUEL
 - Controller transmission: (C/S) ROGER MAYDAY

VTBS/BKK

SUARNABHUMI INTL



26 NOV 21

20-1P8

.Eff.2.Dec.

BANGKOK, THAILAND

AIRPORT BRIEFING

2. ARRIVAL

2.1. SPEED CONTROL AND ALTITUDE RESTRICTIONS IN BANGKOK TMA

In order to facilitate the air traffic flow procedure of arriving aircraft within Bangkok TMA, speed control procedures and altitude restricted must be applied to optimize the spacing between aircraft and reduce the overall delay of traffic.

2.1.1. SPEED CONTROL

- Speed control shall be in force at all times unless otherwise instructed. Pilots will be individually advised by ATC when speed control is cancelled.
- All arriving aircraft are to apply speed of not more than 250 KT when flying at or below altitude of 10,000'.
- Arriving aircraft shall comply with speed control restrictions as published on the RNAV STARs Charts and Instrument Approach Procedures unless otherwise advised by ATC.
- En route and terminal holding speed shall be in accordance with ICAO standard holding speeds requirement. Pilots shall resume speed control procedures when leaving the holding fix.
- ATC may issue further speed adjustment instructions during various flight phases or/and when required by traffic situation.
- All speed restrictions are to be flown as accurately as possible. If unable to conform to these procedures, pilots should immediately inform ATC and state the speed to be used so that an alternative action can be taken.

2.1.2. ALTITUDE RESTRICTIONS

- When an arriving aircraft on a STAR is cleared to descend to a level lower than the level or the level(s) specified in the STAR, the aircraft shall nevertheless follow the published vertical, unless such restrictions are explicitly cancelled by ATC. Published minimum levels based on terrain clearance shall always be strictly applied.
- To facilitate safe traffic integration and provide vertical separation between converging traffic in Bangkok TMA, pilots shall plan their descent profile in accordance with the published STAR procedures or their descent profile against distance to touchdown.
- All altitude restrictions are to be flown as accurately as possible. If unable to conform to these restrictions, pilots should immediately inform ATC so that an alternative action can be taken.

2.2. RADIO COMMUNICATION FAILURE PROCEDURE

2.2.1. TOTAL RADIO COMMUNICATION FAILURE FOR ARRIVING AIRCRAFT

2.2.1.1. If in VMC, continue to fly in VMC and land at the nearest suitable aerodrome.

2.2.1.2. If in IMC or when the pilot of an IFR flight considers it inadvisable to complete the flight in accordance with paragraph 2.2.1.1. above, the pilot shall:

- If a specific STAR procedure has been designated and acknowledged prior to the occurrence of radio communication failure, comply with the radio communication failure procedures.

Proceed according to the STAR route to the termination point (WALTZ/EKCHO for Rwy 19L/R or WOCAL/ENKAA for Rwy 01L/R) and descend in accordance with the published all speed and altitude restrictions of the relevant STAR procedure, thence:

- a. For Rwy 19L/R: After passing WALTZ/EKCHO, the pilot shall fly heading 015[^] and maintain altitude 6000' for next 10 NM, then turn right/left and descend to 2000' and carry out the appropriate ILS approach procedure.
- b. For Rwy 01L/R: After passing WOCAL/ENKAA, the pilot shall fly heading 195[^] and maintain altitude 6000' for next 10 NM, then turn right/left and descend to 2000' and carry out the appropriate ILS approach procedure.

VTBS/BKK



BANGKOK, THAILAND

SUARNABHUMI INTL

26 NOV 21

20-1P9

.Eff.2.Dec.

AIRPORT BRIEFING

2. ARRIVAL

2.2.1. TOTAL RADIO COMMUNICATION FAILURE FOR ARRIVING AIRCRAFT (CONT)

- If no specific STAR procedure has been designated or acknowledged prior to the occurrence of radio communication failure, endeavor to ascertain the landing direction from any available means in paragraph 2.2.4. below. The pilot then should proceed in accordance with the STAR procedure appropriate to its ATS route and landing direction and comply with the radio communication failure procedures.
- 2.2.1.3. When an arriving aircraft is being radar vectored, if no transmissions are heard on the frequency in use for a period of two minutes, a radio frequency check is to be made. If the radio frequency check indicates a radio communication failure, pilot should proceed in the most direct manner possible to rejoin the STAR procedure appropriate to its ATS route and landing direction.
- 2.2.1.4. Pilots should ensure that they remain at or above the minimum sector altitude. If the aircraft is below the minimum sector altitude, pilots shall immediately climb to the minimum sector altitude.

2.2.2. TOTAL RADIO COMMUNICATION FAILURE FOR MISSED APPROACH AIRCRAFT

- 2.2.2.1. The pilot shall set the aircraft transponder to Mode A code 7600 and fly to or proceed direct to (in case of radar vector) the appropriate approach holding point at 3000' and hold.
- 2.2.2.2. The pilot then shall climb and maintain 4000' in the holding pattern and complete one holding then start commencing an appropriate approach procedure and landing direction in accordance with paragraph 2.2.4. below, or
- 2.2.2.3. The pilot shall maintain altitude 4000' and proceed to SVB VOR then transition to IAF and commence an appropriate approach procedure.

2.2.3. PARTIAL RADIO COMMUNICATION FAILURE FOR ARRIVING AIRCRAFT

- 2.2.3.1. Aircraft unable to receive: pilots shall adopt the total radio communication failure procedures specified in paragraph 2.2.1 above.
- 2.2.3.2. Aircraft able to receive: following verification that aircraft is able to receive ground transmissions by squawk ident, ATC will continue to issue and repeat instruction and/or clearance to the pilot.

2.2.4 IDENTIFICATION OF RUNWAY IN USE

- 2.2.4.1. A pilot endeavors to obtain information on the landing runway from the following sources: ATIS, D-ATIS, ACARS, satellite phone, etc. If unable, the pilot should rely on the best available information such as aerodrome weather forecasts, meteorological reports or any other relevant information obtained prior to the communication failure and should decide on the most appropriate landing direction.
- 2.2.4.2. To assist the pilot in ascertaining the landing direction, the ILS and approach lighting for the runway in use will be switched on. If the approach lights for the runway-in-use are sighted but the ILS signal is not received, the pilot shall assume that the ILS is inoperative and shall proceed to land on the runway on which the approach lights have been sighted.

2.3. NOISE ABATEMENT PROCEDURES

2.3.1. FLAP SETTING

- Set minimum certified landing flaps according to the airplane flight manual for the applicable conditions.

2.3.2. THRUST REVERSER

- After landing, limit the use of reverse thrust to idle between 1900 and 2300 UTC, unless it adversely affects the safety of aircraft operations.

2. ARRIVAL

2.4. RWY OPERATIONS

2.4.1. MINIMUM RUNWAY OCCUPANCY TIME

- Shall be strictly applied in order to achieve the highest possible rate for arrivals and departures.
- Pilots are reminded that rapid exit from the landing runway enables ATC to apply minimum spacing on final approach that will achieve maximum runway utilization and will minimize the occurrence of 'go-arounds'.

2.4.2. REDUCE COMMUNICATION WORKLOAD

- To reduce communication workload, additional Arrival Control frequency 126.3 shall be established and used during the congested traffic periods. The control of arriving aircraft shall be transferred from Arrival Control frequency 121.1 to Arrival Control frequency 126.3.

2.4.3. HIGH INTENSITY RUNWAY OPERATION

- Shall be strictly applied in order to achieve the highest possible rate for arrivals and departures.
- To achieve the highest possible rate/hour for arrivals and departures, runway occupancy times are to be reduced to a minimum, as a rule. Runway shall be vacated via high speed turn-offs.
- Whenever runway conditions permit, pilots should prepare their landing so as to vacate the runways via the following high speed turn-offs:

REMARK:

Distance to turn off is the distance of the respective runway to turn-off intersection.

RUNWAY 19L	DISTANCE TO TURN OFF
B8	5381' (1640m)
B10	6726' (2050m)
B11	8399' (2560m)

RUNWAY 19R	DISTANCE TO TURN OFF
E9	4823' (1470m)
E13	6726' (2050m)
E15	8005' (2440m)

RUNWAY 01R	DISTANCE TO TURN OFF
B7	5807' (1770m)
B5	7710' (2350m)
B3	8990' (2740m)

RUNWAY 01L	DISTANCE TO TURN OFF
E12	4462' (1360m)
E7	6726' (2050m)
E5	8399' (2560m)

2.5. FLIGHT PROCEDURES

2.5.1. APPROACH PROCEDURES WITH RADAR CONTROL

- All procedures are designed to maximize departure and arrival capacity in Bangkok TMA and to minimize noise disturbance in areas overflown.
- The final approach may be carried out by means of ILS or other available instrument approach system at the discretion of the pilot.
- The spacing provided between aircraft will be designed to achieve maximum runway utilization within the parameters of safe separation minima including vortex effect and runway occupancy. It is important to validate the separation provided to achieve the optimum runway capacity, that runway occupancy time is kept to a minimum consistent with the prevailing conditions.
- The horizontal radar separation minimum shall be 5NM except within Bangkok TMA, Bangkok CTR and Suvarnabhumi ATZ a reduced separation of 3NM may be applied.

2.5.2. MISSED APPROACH

- As directed by ATC.
- In the absence of instructions from ATC, aircraft shall follow the missed approach procedures contained on the Instrument Approach Charts.

VTBS/BKK

JEPPESEN

BANGKOK, THAILAND

SUARNABHUMI INTL

22 JAN 21 (20-1P11) .Eff.28.Jan.

AIRPORT BRIEFING

3. DEPARTURE

3.1. NOISE ABATEMENT PROCEDURES.

- All departing aircraft are required to apply noise abatement procedure with thrust reduction at 1500' AGL and acceleration at 3000' AGL.

3.2. SPEED CONTROL AND ALTITUDE RESTRICTIONS IN BANGKOK TMA

In order to facilitate the air traffic flow procedure of departing aircraft within Bangkok TMA, speed control procedures and altitude restricted must be applied to optimize the spacing between aircraft and reduce the overall delay of traffic.

3.2.1. SPEED CONTROL

- Speed control shall be in force at all times unless otherwise instructed. Pilots will be individually advised by ATC when speed control is cancelled.
- All departing aircraft are to apply speed of not more than 250 KT when flying at or below altitude of 10,000'.
- Departing aircraft shall comply with speed control restrictions as published in the RNAV SIDs Procedures unless otherwise advised by ATC.
- ATC may issue further speed adjustment instructions during various flight phases or/and when required by traffic situation.
- All speed restrictions are to be flown as accurately as possible. If unable to conform to these procedures, pilots should immediately inform ATC and state the speed to be used so that an alternative action can be taken.

3.2.2. ALTITUDE RESTRICTION

- When a departing aircraft on a SID is cleared to climb to a level higher than the initially cleared level or the level(s) specified in the SID, the aircraft shall nevertheless follow the published vertical profile, unless such restrictions are explicitly cancelled by ATC.
- Departing aircraft intending to cruise below the transition level shall follow an appropriate SID track and comply with individual ATC climb instructions.
- All altitude restrictions are to be flown as accurately as possible. If unable to conform to these restrictions, pilots should immediately inform ATC so that an alternative action can be taken.

3.3. RADIO COMMUNICATION FAILURE PROCEDURE

3.3.1. TOTAL RADIO COMMUNICATION FAILURE FOR DEPARTURING AIRCRAFT

- 3.3.1.1. The pilot shall set the aircraft transponder to Mode A Code 7600 and comply with the last acknowledged clearance up to the next reporting point on the SID, then climb to the planned cruising level in accordance with the published speed and altitude restrictions of the relevant SID procedure. Thereafter, the pilot shall comply with the flight planned routing.
- 3.3.1.2. Whenever a pilot experiences total radio communication failure immediately after departure and it is deemed unsafe for the flight to continue to its destination, the pilot shall adhere to the procedures below:
 - The pilot shall set the aircraft transponder to Mode A Code 7600.
 - The pilot shall comply with the last assigned altitude in accordance with the published speed and altitude restrictions of the relevant SID procedure.
 - The pilot shall climb/descend to maintain 8500' for 2 minutes then proceed direct to BKK VOR and hold. If fuel dumping is necessarily required before making an approach to land, after maintaining altitude at 8500' for 2 minutes, the pilot shall proceed to the nearest suitable fuel dumping area and start dumping fuel. When it is completed, the pilot must fly direct to BKK VOR and hold.
 - The pilot is required to make a left holding pattern over BKK VOR with inbound course 120° and one minute leg to complete one holding then start commencing an appropriate approach procedure and landing direction in accordance with paragraph 2.2.4. ARRIVAL.

VTBS/BKK

JEPPESEN

BANGKOK, THAILAND

SUVARNABHUMI INTL

22 JAN 21

20-1P12

.Eff.28.Jan.

AIRPORT BRIEFING

3. DEPARTURE

3.3.2. PARTIAL RADIO COMMUNICATION FAILURE FOR DEPARTING AIRCRAFT

- 3.3.2.1 Aircraft unable to receive: pilots shall adopt the total radio failure procedures specified in paragraph 3.3.1.2. above.
- 3.3.2.2. Aircraft able to receive: following verification that aircraft is able to receive ground transmissions by squawk ident, ATC will continue to issue and repeat instructions and/or clearances to the pilot.

3.3.3. AIRCRAFT OVERFLYING BANGKOK TMA

- 3.3.3.1 The pilot shall set the aircraft transponder to Mode A Code 7600.
- 3.3.3.2. If in VMC, the pilot shall continue to fly in VMC and land at the nearest suitable aerodrome.
- 3.3.3.3. If in IMC, or when the pilot of an IFR flight considers it inadvisable to complete the flight in accordance with paragraph 3.3.3.2. above, the pilot shall maintain the last assigned speed and level, or minimum flight altitude if higher, for a period of ten minutes following the aircraft's failure to report its position over a compulsory reporting point and thereafter adjust level and speed in accordance with the filed flight plan.

3.3.4. DEPARTING OR OVERFLYING UNDER RADAR CONTROL

- 3.3.4.1 The pilot shall set the aircraft transponder to Mode A Code 7600.
- 3.3.4.2. The pilot shall maintain the last assigned heading, speed and level, or minimum flight altitude if higher, for a period of two minutes following:
- The time the last assigned level or minimum flight altitude is reached; or
 - The time the transponder is set to 7600; or
 - The aircraft's failure to report its position over a compulsory reporting point, whichever is later, and thereafter adjust level and speed in accordance with the filed flight plan.
- 3.3.4.3. After a period of two minutes, the pilot shall proceed in the most direct manner possible to rejoin the SID procedure appropriate to its ATS route or the flight planned route no later than the next significant point, taking into consideration to the applicable minimum flight altitude.

3.4. RWY OPERATIONS

3.4.1. HANDLING SERVICES AND FACILITIES

- For the purpose of noise and emission on the apron area, any aircraft that is designated to park at the stands served with passenger loading bridges shall utilize the fixed ground power supply (400Hz) and the fixed pre-conditioned air supply provided by the airport if in service.
- Fixed ground power supply (400Hz) - Operators are recommended to reduce electric load immediately after parking. If fixed ground power supply is out of service, mobile GPU may be used. APU shall not be used more than 10 minutes before off-block time and 5 minutes after parking. If the operators request to operate the APU, the aircrafts shall be allocated to the remote stand.
- Fixed pre-conditioned air supply: Operators are recommended to turn off the cabin air re-circulation system to prevent outside air mixing with PC-Air, if fixed PCA is out of service, mobile ACU may be used.
- Visual Docking Guidance System is provided at all stands. If VDGS is out of service, a marshaller shall guide the aircraft from the taxiway to the parking position on the stand.

3.3.2. ACTION TO BE TAKEN BY THE PILOT IN COMMAND

When the aircraft is fully ready the pilot-in-command shall :

- Ensure that the area behind an aircraft is clear of vehicles, equipment and other obstructions before the start-up or pushback of aircraft commences. This is to be done using standard phraseology in communication with the ground operations headset operator.

VTBS/BKK

JEPPESEN

BANGKOK, THAILAND

SUVARNABHUMI INTL

22 JAN 21

20-1P13

.Eff.28.Jan.

AIRPORT BRIEFING

3. DEPARTURE

I 3.3.2. ACTION TO BE TAKEN BY THE PILOT IN COMMAND (CONT)

- Ensure that prior to start-up, the pilot must be certain that the propellers or the air flows caused by the engine cannot cause injuries or damage to persons or property on ground. This is to be done using standard phraseology in communication with the operations headset operator.
- Contact Ground Control for permission to start up the engines.
In normal operations, the engine start-up at the aircraft parking position is not allowed. Should the engine start be performed at the aircraft parking positions, ensure that the requirements for such engine start up conditions are met.
- Ensure that the ground engineer, or the person responsible for ground to cockpit communications who is in direct intercom-radio contact with the pilot-in-command, acknowledges the start up permission. In the event intercom-radio contact is not available, the use of standard hand signals will be used.
- Ensure that the anti-collision beacons of the aircraft have been switched on before pushing back or starting the engine. Ensure to obtain an "all-clear" signal from the ground operations headset operator.
- During pushback operations, all aircraft shall be pushed back with its fuselage longitudinally centered over, and parallel to, a taxiway centerline before commencing engine start.
- Ensure that the ground engineer or ground operations headset operator acknowledges the permission.
- Ensure that the aircraft is being pushed back in the right direction onto the taxilane.
- Request permission from Ground Control to taxi when the tug has been disconnected as confirmed by the ground engineer and the ground engineer or ground operations headset operator has given the "all clear" signal.

I 3.3.3. PUSH BACK PROCEDURES

- Aircraft which are parked either nose in to the terminal building on a stand attached to a PASSENGER LOADING BRIDGE or nose in on a remote stand will need to be pushed back from the stand towards the taxilane center line taking into account the standard taxiway routing.
- Once the pilot-in-command of an aircraft has decided that the aircraft is fully ready for departure he/she will contact Ground Control for start up, stating the parking position, and after that for push back permission.
- Note- Fully ready in this sense means all passengers, hold and cargo doors are closed, the Passenger Loading Bridge is disconnected and back in its rest position, the tug is connected to the aircraft and the ground engineer is in position and in contact with the pilot in command.
- When the anti-collision beacons of the aircraft have been switched on no vehicular movement is permitted behind the aircraft.
- ATC may deviate from the standard push back procedure as stated below for reasons such as traffic or work in progress. The deviation will be given in the push back permission and the pilot-in-command has to make sure that the ground engineer fully understands the deviation.
- The PIC shall use minimum break away power and minimum taxi power when operating on the aprons and taxi lanes.
- Nose wheel positions have been marked on the taxilane center line to indicate to the driver where the push pull maneuver has to be stopped and the tug can be disconnected.
- A 340-600 aircraft may only be pushed back using a towbarless tow tractor.
This is to avoid blocking the road in front of the aircraft by a tractor with towbar.
- While the aircraft is being pushed back from parking bay and/or being on the taxilane ready to take off with all engines started, operate normal procedures until they are completed and the aircraft has taken off.

VTBS/BKK



BANGKOK, THAILAND

SUARNABHUMI INTL

22 JAN 21

20-1P14

.Eff.28.Jan.

AIRPORT BRIEFING

3. DEPARTURE

AIRCRAFT PARKING AT MAIN APRON (26 STANDS)

Aircraft stands	Frequency Ground Control	Push Back Instructions
C2	121.75	Aircraft shall be pushed back to face east onto aircraft stand taxi lane T12 until aircraft nose wheel is on marking 1.
C4, C6	121.75	Aircraft shall be pushed back to face south onto aircraft stand taxi lane T8 and then towed forward until aircraft nose wheel is on marking 2.
C8, C10	121.75	Aircraft shall be pushed back to face south onto aircraft stand taxi lane T8 and then towed forward until aircraft nose wheel is on marking 1.
301	121.75	Aircraft shall be pushed back to face north onto aircraft stand taxi lane T9 until aircraft nose wheel is on marking 1.
302	121.75	Aircraft shall be pushed back to face north onto aircraft stand taxi lane T9 and then towed forward until aircraft nose wheel is on marking 1.
303	121.75	Aircraft shall be pushed back to face north onto aircraft stand taxi lane T9 until aircraft nose wheel is on marking 2.
304	121.75	Aircraft shall be pushed back to face north onto aircraft stand taxi lane T9 and then towed forward until aircraft nose wheel is on marking 2.
305	121.75	Aircraft shall be pushed back to face north onto aircraft stand taxi lane T10 until aircraft nose wheel is on marking 1.
306	121.75	Aircraft shall be pushed back to face north onto aircraft stand taxi lane T10 and then towed forward until aircraft nose wheel is on marking 1.
307	121.75	Aircraft shall be pushed back to face north onto aircraft stand taxi lane T10 until aircraft nose wheel is on marking 2.
308	121.75	Aircraft shall be pushed back to face north onto aircraft stand taxi lane T10 and then towed forward until aircraft nose wheel is on marking 2.
D1	121.75	Aircraft shall be pushed back to face east onto aircraft stand taxi lane T12 until aircraft nose wheel is on marking 1.
D2	121.75	Aircraft shall be pushed back to face east onto aircraft stand taxi lane T12 and then towed forward until aircraft nose wheel is on marking 1.
D3	121.75	Aircraft shall be pushed back to face east onto aircraft stand taxi lane T12 until aircraft nose wheel is on marking 2.
D4	121.75	Aircraft shall be pushed back to face east onto aircraft stand taxi lane T12 and then towed forward until aircraft nose wheel is on marking 2.
D5	121.75	Aircraft shall be pushed back to face west onto aircraft stand taxi lane T12 and then towed forward until aircraft nose wheel is on marking 3.
D6	121.75	Aircraft shall be pushed back to face west onto aircraft stand taxi lane T12 until aircraft nose wheel is on marking 3.
D7	121.75	Aircraft shall be pushed back to face west onto aircraft stand taxi lane T12 and then towed forward until aircraft nose wheel is on marking 4.
D8	121.75	Aircraft shall be pushed back to face west onto aircraft stand taxi lane T12 until aircraft nose wheel is on marking 4.
E1	121.75	Aircraft shall be pushed back to face west onto aircraft stand taxi lane T12 until aircraft nose wheel is on marking 4.
E3, E5	121.75	Aircraft shall be pushed back to face south onto aircraft stand taxi lane T11 and then towed forward until aircraft nose wheel is on marking 2.
E7, E9	121.75	Aircraft shall be pushed back to face south onto aircraft stand taxi lane T11 and then towed forward until aircraft nose wheel is on marking 1.

VTBS/BKK

 22 JAN 21 (20-1P15) .Eff.28.Jan.

BANGKOK, THAILAND

SUARNABHUMI INTL

AIRPORT BRIEFING

3. DEPARTURE

AIRCRAFT PARKING AT EAST APRON (54 STANDS)

Aircraft stands	Frequency Ground Control	Push Back Instructions
A1, A2	121.65	Aircraft shall be pushed back to face south onto aircraft stand taxi lane T5 until aircraft nose wheel is on marking 1.
A3, A4, A5, A6	121.65	Aircraft shall be pushed back to face south onto aircraft stand taxi lane T5.
101	121.65	Aircraft shall be pushed back to face south onto aircraft stand taxi lane T5 and then towed forward until aircraft nose wheel is on marking 2.
102, 103	121.65	Aircraft shall be pushed back to face north onto aircraft stand taxi lane T5 and then towed forward until aircraft nose wheel is on marking 3.
104, 105, 106 107	121.65	Aircraft shall be pushed back to face north onto aircraft stand taxi lane T5.
108, 109	121.65	Aircraft shall be pushed back to face north onto aircraft stand taxi lane T5 then towed forward until aircraft nose wheel is on marking 4.
110, 111, 112 113, 114	121.65	Aircraft shall be pushed back to face north onto aircraft stand taxi lane T5.
115, 116, 117	121.65	Aircraft shall be pushed back to face south onto aircraft stand taxi lane T5.
118	121.65	Aircraft shall be pushed back to face south onto aircraft stand taxi lane T5 and then towed forward until aircraft nose wheel is on marking 2.
119	121.65	Aircraft shall be pushed back to face north onto aircraft stand taxi lane T5 then towed forward until aircraft nose wheel is on marking 3.
120, 121, 122 123	121.65	Aircraft shall be pushed back to face north onto aircraft stand taxi lane T5.
124	121.65	Aircraft shall be pushed back to face north onto aircraft stand taxi lane T5 then towed forward until aircraft nose wheel is on marking 4.
125, 126, 127 128, 129	121.65	Aircraft shall be pushed back to face north onto aircraft stand taxi lane T5.
130, 131, 132 133, 134	121.65	Aircraft shall be pushed back to face east onto aircraft stand taxi lane T1.
B1, B3	121.65	Aircraft shall be pushed back to face south onto aircraft stand taxi lane T5 until aircraft nose wheel is on marking 1.
B2, B4	121.65	Aircraft shall be pushed back to face west onto aircraft stand taxi lane T6 until aircraft nose wheel is on marking on taxi lane.
B5	121.65	Aircraft shall be pushed back to face east onto aircraft stand taxi lane T4 then towed forward until aircraft nose wheel is on marking on taxi lane..
B6	121.65	Aircraft shall be pushed back to face west onto aircraft stand taxi lane T6 and then towed forward until aircraft nose wheel is on marking on taxi lane.
C1	121.65	Aircraft shall be pushed back to face west onto aircraft stand taxi lane T6 then towed forward until aircraft nose wheel is on marking on taxi lane.
C3, C5	121.65	Aircraft shall be pushed back to face south onto aircraft stand taxi lane T7 then towed forward until aircraft nose wheel is on marking 2.
C7, C9	121.65	Aircraft shall be pushed back to face south onto aircraft stand taxi lane T7 and then towed forward until aircraft nose wheel is on marking 1.
201, 202	121.65	Aircraft shall be pushed back to face south onto aircraft stand taxi lane T7 and then towed forward until aircraft nose wheel is on marking 2.
203	121.65	Aircraft shall be pushed back to face south onto aircraft stand taxi lane T7 and then towed forward until aircraft nose wheel is on marking 1.

VTBS/BKK

 22 JAN 21 (20-1P16) .Eff.28.Jan.

BANGKOK, THAILAND

SUARNABHUMI INTL

AIRPORT BRIEFING

3. DEPARTURE

AIRCRAFT PARKING AT WEST APRON (44 STANDS)

Aircraft stands	Frequency Ground Control	Push Back Instructions
E2	121.95	Aircraft shall be pushed back to face east onto aircraft stand taxi lane T14 until aircraft nose wheel is on marking on taxi lane.
E4, E6	121.95	Aircraft shall be pushed back to face south onto aircraft stand taxi lane T13 and then towed forward until aircraft nose wheel is on marking 2.
E8, E10	121.95	Aircraft shall be pushed back to face south onto aircraft stand taxi lane T13 and then towed forward until aircraft nose wheel is on marking 1.
401, 402	121.95	Aircraft shall be pushed back to face south onto aircraft stand taxi lane T13 until aircraft nose wheel is on marking 2.
403	121.95	Aircraft shall be pushed back to face south onto aircraft stand taxi lane T13 and then towed forward until aircraft nose wheel is on marking 1.
F1, F3	121.95	Aircraft shall be pushed back to face east onto aircraft stand taxi lane T14 until aircraft nose wheel is on marking on taxi lane.
F2, F4	121.95	Aircraft shall be pushed back to face east onto aircraft stand taxi lane T15 until aircraft nose wheel is on marking on taxi lane.
F5	121.95	Aircraft shall be pushed back to face east onto aircraft stand taxi lane T14 and then towed forward until aircraft nose wheel is on marking on taxi lane.
F6	121.95	Aircraft shall be pushed back to face east onto aircraft stand taxi lane T15 and then towed forward until aircraft nose wheel is on marking 1.
G1, G2	121.95	Aircraft shall be pushed back to face east onto aircraft stand taxi lane T15 until aircraft nose wheel is on marking on taxi lane.
G3, G4	121.95	Aircraft shall be pushed back to face north onto aircraft stand taxi lane T17 and then towed forward until aircraft nose wheel is on marking 2.
G5	121.95	Aircraft shall be pushed back to face north onto aircraft stand taxi lane T17 and then towed forward until aircraft nose wheel is on marking 1.
501	121.95	Aircraft shall be pushed back to face north onto aircraft stand taxi lane T17 and then towed forward until aircraft nose wheel is on marking 1.
502, 503	121.95	Aircraft shall be pushed back to face north onto aircraft stand taxi lane T17 and then towed forward until aircraft nose wheel is on marking 2.
504, 505	121.95	Aircraft shall be pushed back to face north onto aircraft stand taxi lane T17 and then towed forward until aircraft nose wheel is on marking 1.
506 - 521	121.95	Aircraft shall be pushed back to face south onto taxiway D.
522 - 525	121.95	Aircraft shall be pushed back to face south onto taxiway D, then towed forward until abeam stand 522 with nose wheel on marking on taxiway.

3.4. ATC CLEARANCE PROCEDURES

3.4.1. ISSUANCE OF ATC CLEARANCE

- When flight formalities have been completed and aircraft is ready for departure (all doors are closed), all aircraft are to call Suvarnabhumi Clearance Delivery Control (CDC) for ATC clearance including the aircraft call sign, aircraft type, destination, route, proposed flight level, if different from the filed flight plan and, when applicable, special requirements (e.g. inability to comply with SID climb profile), on the clearance delivery frequencies as depicted on the 20-9 chart.

(Except : IFR aircraft departing to VTBD, VTBU, VTBK, VTBL, VTPI and VTPH at or below FL160 are to call Bangkok Approach on 125.8 MHz)

- To improve tactical management of air traffic, minimize delay as well as reduce controllers and pilots workload, the following procedure will be applied:
 - a) Under normal circumstances, altitude 6000' shall be initially assigned.
 - b) First airborne first flight level selection principle.
 - c) No one ground flight level negotiation and reservations.
 - d) Cruising level shall be assigned by Bangkok Control after airborne.

VTBS/BKK



BANGKOK, THAILAND

SUARNABHUMI INTL

22 JAN 21 (20-1P17) .Eff.28.Jan.

AIRPORT BRIEFING

3. DEPARTURE

3.4.2. DEPARTURE TIME RESTRICTION

- Departure time restrictions may be imposed for Air Traffic Management when so required.
- When ATC clearance includes departure time restrictions, pilots shall:
 - a) keep listening watch on relevant Suvarnabhumi Ground Control frequency at all times for additional or revised ATC clearance and in readiness for push back; and
 - b) call Ground Control in the appropriate time with the departure time restriction.
- Failure to comply with 3.4.2.a and 3.4.2.b will result in cancellation of ATC clearance.

3.4.3. CANCELLATION OF ATC CLEARANCE

- Once ATC clearance has been received, unless there is a departure time restriction included in ATC clearance or other restriction resulting from Air Traffic Management, the aircraft must be pushed back within 5 minutes from the time ATC clearance is received, otherwise ATC clearance will be cancelled.
- Additionally, in order to provide a more flexible ground traffic movement, all domestic departures shall no longer be required to push back within 5 minutes after clearance received.

After ATC clearance is received, pilot shall contact defined ground control frequency according to the parking stand for start up and push back.

3.5. DEPARTURE PROCEDURES

3.5.1. OPERATIONAL FOR SAFETY AND MORE EFFECTIVE AIR TRAFFIC MANAGEMENT IN BANGKOK TMA

Suvarnabhumi Departure shall be established to provide Air Traffic Control Service at Suvarnabhumi International Airport, the operational procedures shall be as follows:

- All departing aircraft, before transferring to relevant approach sectors (East, West, South and North), are strictly required to contact Suvarnabhumi Departure on frequency 119.25 immediately after airborne unless otherwise instructed by ATC.
- Pilots shall be reminded that, to reduce communication workload, the departure frequency shall not be included in take-off clearance.
- Air Traffic Management for flight operating on ATS route A202, departure aircraft shall flight plan via A1 SELKA DCT RAMEI A202.

3.5.2. RUNWAY-IN-USE

- The runway-in-use is selected by Suvarnabhumi Control Tower as the best for general purpose. If it is unsuitable for a particular operation, the pilot can obtain permission from ATC to use another but must accept that he may thereby incur a delay.

3.5.3. DEPARTURE SEQUENCE

- Departure shall normally be cleared in the order in which they are ready for take-off, except that deviations may be made from this order of priority to facilitate the maximum number of departures with the least average delay.
- To increase runway capacity and to comply with slot times if required, ATC may re-order departure sequence at any time. In addition, intersections will be assigned for departure. Pilots unable to accept the reduced take-off run available for the assigned intersection, shall inform ATC directly.

3.5.4. DEPARTURE CLEARANCE

- The order in which aircraft are given take-off clearances will be determined on the basis of normal traffic priorities, the application of wake turbulence standard separation and departure slot allocations and management.
- Under normal circumstances all departing aircraft will be issued with SIDs. If, for traffic management reasons, a SID has to be cancelled, the pilot will be given a specific departure instruction.
- If, after take-off, a pilot experiences radio failure, he/she shall comply with communication failure procedures as published in the RNAV SID Charts.

VTBS/BKK

22 JAN 21



20-1P18

.Eff.28.Jan.

BANGKOK, THAILAND

SUVARNABHUMI INTL

AIRPORT BRIEFING

3. DEPARTURE

I 3.5.5. INTERSECTION DEPARTURE

- Departing aircraft will normally be directed by ATC to use the full length of the runway for take-off. Pilots-in-command may request or ATC may propose an intersection departure to resolve a particular runway or maneuvering area conflict. The final decision whether to make an intersection departure rests with the pilot-in-command.

I 3.5.6. CLEARANCE FOR IMMEDIATE TAKE-OFF

- A pilot receiving an immediate take-off instruction is required to act as follows:
 - a) if waiting clear of the runway, taxi immediately to runway and begin take-off run without stopping aircraft;
 - b) if already lined up on the runway, take-off without delay;
 - c) if unable to comply with the instruction, inform ATC immediately.

I 3.5.7. MINIMUM RUNWAY OCCUPANCY TIME

- On receipt of line-up clearance pilots should ensure, commensurate with safety and standard operation procedures, that they are able to taxi into the correct position at the hold and line up on the runway as soon as the preceding aircraft has commenced its take-off roll.
- Whenever possible, cockpit checks should be completed prior to line up and any checks requiring completion while on the runway should be kept to the minimum required. Pilots should ensure that they are able to commence the take-off roll immediately after take-off clearance is issued.
- Pilots not able to comply with these requirements should notify ATC as soon as possible.
- Pilots shall prepare for the following take-off run available (TORA):

RUNWAY 19L	TORA
B1	13123' (4000m)
B2	12697' (3870m)

RUNWAY 19R	TORA
E1	12139' (3700m)
E2	11778' (3590m)

RUNWAY 01R	TORA
B13	13123' (4000m)
B12	12762' (3890m)

RUNWAY 01L	TORA
E21	12139' (3700m)
E19	11778' (3590m)

- In order to expedite departure traffic, the runway declared distance at each additional available departing point when entering from taxiway, are as follows:

RUNWAY 19L	TORA
B3	9744' (2970m)

RUNWAY 19R	TORA
E5	9121' (2780m)

RUNWAY 01L	TORA
E15	9760' (2670m)

RUNWAY 01R	TORA
B11	9121' (2780m)

Remarks: The aircraft take-off from these points shall be approved when traffic permitted in VMC only.

VTBS/BKK



BANGKOK, THAILAND

SUARNABHUMI INTL

22 JAN 21

20-1P19 .Eff.28.Jan.

AIRPORT BRIEFING

4. PRE-DEPARTURE CLEARANCE (PDC)

4.1. Introduction

- 4.1.1 Bangkok Area Control Center (BACC) has implemented a Pre-Departure Clearance (PDC) over Data Link service at Suvarnabhumi Airport. This procedure provides advance notification to operators for their necessary planning and preparation.
- 4.1.2 Implementation of the PDC over Data Link service is effective 24 hr.
- 4.1.3 The PDC service aims to further improve the accuracy and reliability in PDC operations, reduce the workload of pilots and ATC and reduce congestion on the Clearance Delivery Control radio frequency.

4.2. Data Link Service

- 4.2.1 The PDC data link procedure will be applied to flights departing from Suvarnabhumi Airport on the following ATS Routes:
 - a. Southbound: A464 / M751 / W19 / G458
 - b. Eastbound: A1 / A202 / W1
 - c. Eastbound: G474 / R468 / N891 RYN M644 OR N891 RYN R334 EXCEPT ROUTING N891 RYN N891 BENSA
 - d. Northbound: A464 / R474 / W9 / W21 / B346
- 4.2.2 The PDC data link will be applied under the following principles:
 - a. Under normal circumstances, initial level of FL160 shall be assigned
 - b. First airborne first flight level selection principle
 - c. No on-ground flight level negotiation and reservations
 - d. Final cruising level shall be assigned by Bangkok Control after airborne
 - e. Flight requesting level lower than FL160 shall be cleared accordingly
- 4.2.3 With PDC operations, request for departure clearance will be initiated by the pilot. After satisfactory verification of the request, the BACC PDC system will respond with the departure clearance message.
- 4.2.4 All PDC messages (such as departure request, departure clearance and read back) between aircraft and PDC system will be exchanged in accordance with the Airlines Electronic Engineering Committee (AEEC) Specification 623 (AEEC623: Character-Oriented Air Traffic Service (ATS) Applications) for departure clearance and transmitted via data link service providers, between the aircraft and the PDC system directly.

4.3 Operators' Equipment Requirements

- 4.3.1 Aircraft equipped with Aircraft Communications Addressing and Reporting System (ACARS) equipment and compliant with AEEC623 may utilize the PDC over data link.

4.4 PDC Pilots' Procedures

1. Pilot should initiate a PDC request within 20 minutes prior to aircraft being ready for departure (all doors closed) using appropriate ICAO call sign and departure airport ("VTBS").
2. Pilot will receive a message ("RCD RECEIVED, REQUEST BEING PROCESSED, STANDBY") to inform that PDC uplink message (CLD) will be delivered shortly. Sample CLD message format is provided in Attachment.
3. Within 5 minutes after receiving the PDC uplink message (CLD), pilot shall select the "ACCEPT" function on the flight deck to acknowledge the clearance over data link.
4. Upon reception of clearance acceptance, pilot will receive a confirmation message ("CDA RECEIVED CLEARANCE CONFIRMED") completing en route clearance, waiving the requirement that "the aircraft must be pushed back within 5 minutes".
5. When flight formalities have been completed and aircraft is ready for departure (all doors are closed), pilot shall call the relevant Ground Control frequency for push back and start up.

(continued)

VTBS/BKK



BANGKOK, THAILAND

SUVARNABHUMI INTL

22 JAN 21

20-1P20

.Eff.28.Jan.

AIRPORT BRIEFING

4. PRE-DEPARTURE CLEARANCE (PDC)

(Contd)

4.5. Contingency Procedure

4.5.1 If there is any problem with the data link exchanges, pilot shall request the clearance via voice using the following frequencies:

Frequency	Direction	ATS Route
120.8	Southbound	A464 / M751 / W19 / G458
133.8	Eastbound	A1 / A202 / W1
135.8	Eastbound	G474 / R468 / N891
128.7	Northbound	A464 / R474 / W9 / W21 / B346

Table 1 - PDC Message Format

Line Number	Message Format
1	" PDC" , Clearance Number
2	Flight ID " CLRD TO" Destination Airport " OFF" Runway " VIA" SID Transition " TRANSITION" Route Flight Level
3	" SQUAWK" Ssr Code

Notes:

1. Fields in Bold will be generated by the PDC system or manually input by ATC controller.
2. Each line is ended by CR LF ASCII characters.

Figure 1 - Sample PDC Message

PDC 001
 THA281 CLR**D** TO VTSM OFF 19L VIA SEESA1C REGOS
 TRANSITION W32 FL160 SQUAWK 7211

VTBS/BKK



BANGKOK, THAILAND

SUARNABHUMI INTL

22 JAN 21

20-1P21

.Eff.28.Jan.

AIRPORT BRIEFING

OPERATIONAL PROCEDURES FOR STARTING AND RUNNING OF AIRCRAFT ENGINES

INTRODUCTION

Suvarnabhumi International Airport has developed the following procedures in regards to starting and running of aircraft engines. It is important for aircraft operators and related stakeholders to strictly adhere to the below mentioned procedures. This is in order to ensure a maximum level of safety in the airside operations area for all related parties.

STARTING OR RUNNING OF AIRCRAFT ENGINES

1. In normal operations, engine start-up at the aircraft parking position is not allowed. Aircraft operators wishing to start or run aircraft engines at the aircraft parking positions, shall ensure that the following conditions are met:
 - The aircrafts engine(s) are running at minimum idle power.
 - The aircraft is properly parked with its fuselage longitudinally centered over the lead line and nose gear on top of the parking position painted nose block marking.
 - The aircraft operator shall provide additional ground staff as wing walkers to lookout on both sides of the aircraft; he/she must keep an eye on specific parts of the aircraft when it is moving and safeguard the rear movement of the aircraft to ensure safe clearance and to prevent collision. He/she must be in constant communications with the person in charge of the operation.
 - The aircraft operator seeks permission from the Ground Control prior to starting the engine(s).
 - No other aircraft with ground crew in attendance is on the taxiway centerline or about to pushback from an adjacent stand on to the centerline behind the aircraft waiting to start.
 - The PIC receives an "all-clear" visual and audible signal from the ground engineer or the ground operations headset operator that it is safe to start the engine(s). The PIC must bear in mind that even though the start engine's permission is received from the Ground Control, the ground engineer or the ground operations headset operator has the final authority that the environment around the aircraft is safe for the engine(s) to be started.
 - The ground crew must ensure that the area behind the aircraft is clear of vehicles, equipment and other obstructions before the start-up or pushback of aircraft commences.
 - Minimum power idle engine runs are limited to ten (10) minutes in duration. Otherwise, the operations must be done at the run up area or aircraft parking position with no operations conducted in the adjacent area, or as stipulated/directed by the Airside Operations Control Center (AOCC) Tel: +66 2 132 4110.

2. For the purpose of noise and carbon emission reduction on the apron area, any aircraft that is designated to park at the stand served with passenger loading bridges shall utilize the fixed ground power supply (400Hz) and fixed pre-conditioned air supply provided by the airport if serviceable.
 - Fixed ground power supply (400Hz): Operators are recommended to reduce electric load immediately after parking. If fixed ground power supply is out of service, mobile GPU or APU may be used with consent from AOCC.
 - APU shall not be used more than 10 minutes before off-block time and 5 minutes after parking.
 - If the operator needs to run an APU more than the mentioned time length, they must seek approval from the AOCC. Any acts of non-compliance by the aircraft operator will result in actions being taken by the airport authority, including the assignment of parking stand to a remote area.
 - Aircraft operators that would like to run the APU for an extended period of time shall notify the ground staff to ensure that they are prepared for the effect of extra ground noise.
 - Fixed Pre-Conditioned Air (PCA) supply: Operators are recommended to turn off the cabin air re-circulation system to prevent outside air mixing with PC-Air. If fixed PCA is out of service, mobile ACU may be used with consent from AOCC.

VTBS/BKK



BANGKOK, THAILAND

SUARNABHUMI INTL

22 JAN 21

20-1P22 .Eff.28.Jan.

AIRPORT BRIEFING

OPERATIONAL PROCEDURES FOR STARTING AND RUNNING OF AIRCRAFT ENGINES

(Contd)

3. No aircraft engine shall be started or run unless a licensed pilot or certified mechanic is attending the aircraft controls. Wheel blocks equipped with ropes or other suitable means of chocking the wheels of an aircraft to deter movement shall always be placed in front of the main landing wheels before starting the engine(s), unless the aircraft is locked into position by functioning locking brakes.
4. All aircraft shall be started and run-up in locations, including leased premises, designated for such purposes by the AOCC (Tel. +66 2 132 4110). Maintenance run of aircraft engines shall not be performed in the passenger ramp, apron, cargo and public parking areas.
5. During pushback operations, all aircraft should be pushed back with its fuselage longitudinally centered over, and parallel to a taxiway centerline before commencing engine start. If the PIC wishes to start the engine(s) during push-back, he/she shall coordinate with the ground crew.
6. Running an aircraft engine is prohibited unless reasonably necessary for maintenance purposes, testing or repairing of such engine. The instruction of mechanics or pilots, or the movement/flight operation of such aircraft must be done with strict compliance to Suvarnabhumi Airport Noise Abatement procedures.
7. Turbo jet and turbo fan cross-bleed engine air-start of multi-engine jet aircraft may be conducted on taxiways, provided that the following conditions are met:
 - The aircraft Auxiliary Power Units (APU) is inoperative.
 - The aircraft operator seeks permission from the Ground Control prior to starting engines.
 - Cross-bleed engine start procedure is conducted while the aircraft is longitudinally centered over and parallel to a taxiway centerline while the engine start is being performed.
8. Aircraft of departing flights on aircraft parking positions that are subject to delay are prohibited from running the engine(s). Aircraft power supply must be provided by either: the Passenger Boarding Bridge, APU, or other Ground Power Unit (GPU).
9. The starting or operating of aircraft engines inside any hangar or within 7.5 m radius of any building or other structure is prohibited.
10. No aircraft engine exhaust, blast, and/or propeller wash shall be directed in such a manner as to cause injury, damage, or hazard to any person, aircraft, vehicles, equipment, or structure. If it is impossible to taxi the aircraft without compliance with the above, the engine(s) must be shut off and the aircraft must be towed.
11. Aircraft engines shall not be operated during refueling or defueling operations; or, during a fuel spill unless otherwise approved by the Aircraft Rescue and Fire Fighting (ARFF) Officer in Charge.

RUN-UP OF AIRCRAFT ENGINES

1. High power run of aircraft engines is prohibited at all aircraft parking positions.
2. All non-essential preflight engine run-ups shall be conducted during the hours of 0700 - 2200 local time (in case of urgency, the extension of operation hours may be extended up to 0200 local time) at the run up area located at the south end of Taxiway C, between C8 - C10. Given the proximity of the noise sensitive areas, it is the responsibility of all airport users to strictly limit the engine run-ups that are done on an urgency basis. For those that are absolutely critical and cannot be postponed until the next day, the run-ups may be performed beyond 0200 local time.
3. Aircraft engines shall not be run in hangars, except in approved engine test areas. Aircraft engines shall be run-up only in designated areas. At no times shall engines be run-up when aircraft is inside any hangar or within 7.5 m radius of any building or other structures, or when persons in observation areas are in the proximity of the propeller slipstream or jet blast.

VTBS/BKK

 JEPPESEN

BANGKOK, THAILAND

SUVARNABHUMI INTL

22 JAN 21

20-1P23 .Eff.28.Jan.

AIRPORT BRIEFING

OPERATIONAL PROCEDURES FOR STARTING AND RUNNING OF
AIRCRAFT ENGINES

(Contd)

4. Aircraft operators must obtain location approval and instructions from AOCC (Tel. +66 2 132 4110), before conducting an extended run of any aircraft engine above minimum idle power; high power engine operation, or engine run.
5. Leak checks, one (1) engines power at idle thrust only per start, may be performed at aircraft parking areas that is limited to ten (10) minutes, provided that the operator provides adequate measures to protect personnel and equipment operating behind the aircraft, and the leak check does not interfere with the use of adjacent gate operations.
6. Idle engine checks and auxiliary power units are to be operated at the minimum time required to accomplish the necessary maintenance or preflight check.

AIRPORT COLLABORATIVE DECISION MAKING (A-CDM) AT SUVARNABHUMI INTL AIRPORT

1. DEFINITION OF TERMS COMMONLY USED IN A-CDM

- 1.1 Target Off-Block Time (TOBT) - The time that an Aircraft Operator (AO) or Ground Handler (GH) estimates that an aircraft will be ready, all doors closed, boarding bridge removed, push back vehicle available and ready to start-up and push back immediately upon reception of clearance from the Aerodrome Control Tower (TWR).
- 1.2 Target Start-Up Approval Time (TSAT) - The time provided by ATC taking into account TOBT, CTOT and/or the traffic situation that an aircraft can expect start-up/push back approval.
- 1.3 Calculated Take-Off Time (CTOT) - A time calculated and issued by the appropriate Central Management unit, as a result of tactical slot allocation, at which a flight is expected to become airborne.

2. A-CDM OPERATION AT SUVARNABHUMI INTERNATIONAL AIRPORT

- 2.1 The objectives of A-CDM operation are as follows:
 - 2.1.1 To increase efficiency of Pre-departure sequence for flight depart from Don Mueang International Airport by applying TOBT and TSAT.
 - 2.1.2 To allow Aircraft Operator (AO)/Ground Handler (GH) to be familiar with how to notify TOBT and TSAT to pilots.
 - 2.1.3 To verify TSAT issuance by iDEP system and to assess accuracy of TSAT.
- 2.2 All Departure flights are required to participate in the A-CDM operation.
- 2.3 Aircraft Operator (AO)/Ground Handler (GH) are to follow A-CDM TOBT procedures, TSAT procedures and Pilots/ATC are to follow start-up and push back procedures.

3. SUVARNABHUMI A-CDM PROCEDURES

3.1 Suvarnabhumi A-CDM Procedure Overview

The chart below describes the simple overview of the A-CDM process at Suvarnabhumi International Airport from the time that airlines input the TOBT to the time that aircraft is airborne. It includes the responsibilities and procedures in brief, as described below.

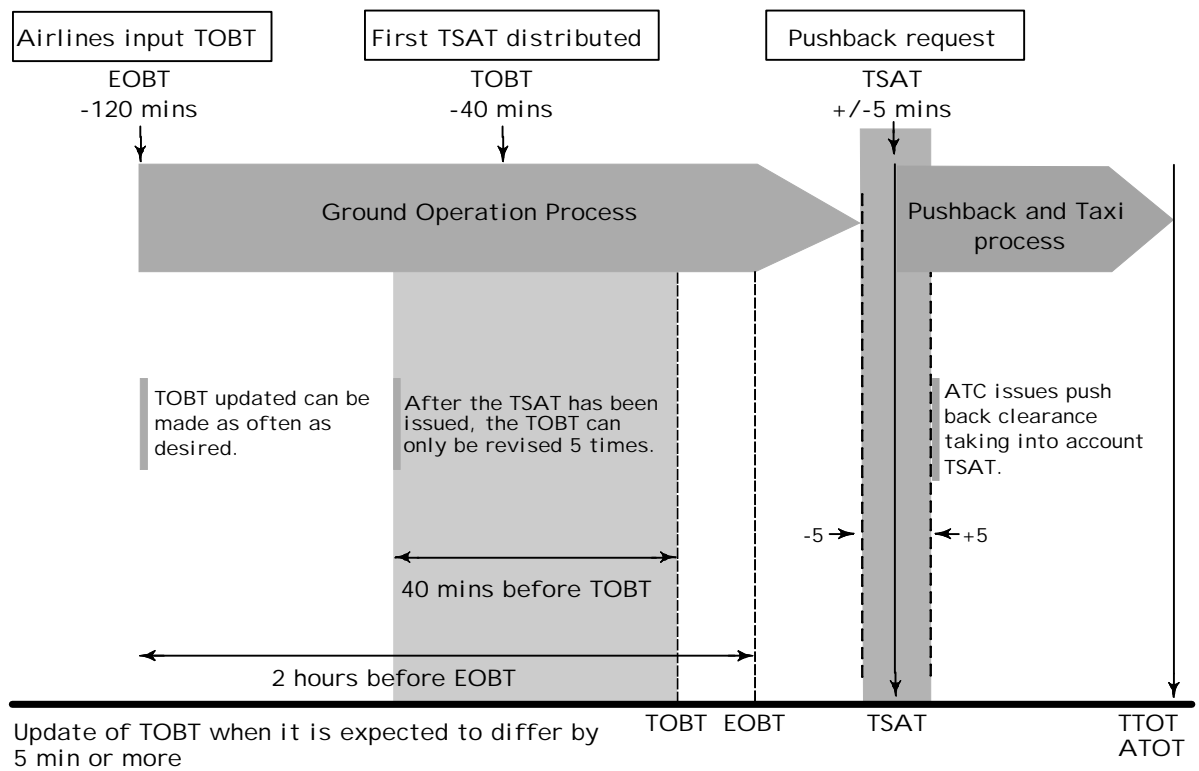

VTBS/BKK

JEPPESSEN

BANGKOK, THAILAND

SUARNABHUMI INTL

11 NOV 22

20-1P25

AIRPORT BRIEFING

AIRPORT COLLABORATIVE DECISION MAKING (A-CDM) AT SUARNABHUMI INTL AIRPORT (CONTD)

3.2 Target Off-Block Time (TOBT) Procedures

3.2.1 General

Airlines or person responsible for the TOBT are required to access and manually input the TOBT into the iDEP system in order that the start-up approval time (TSAT) can be expected.

3.2.2 Person Responsible for TOBT

-Airline operator (AO) is responsible for the input of and adherence to the TOBT. However, AO may prefer to delegate this function to ground handler (GH). It is the responsibility of the AO/GH to communicate and ensure that the pilot of a flight has the correct TOBT and TSAT prior to requesting ATC clearance.

-AO need to ensure that a timely, accurate and stable TOBT is provided. If it becomes obvious that the TOBT cannot be respected, it shall be updated by the person responsible for the TOBT as early as possible.

3.2.3 TOBT Input and Revision

The following has to be taken into account for the input and/or revision of the TOBT:

- a) The first TOBT can be input at 120 minutes (2 hours) prior to EOBT.
- b) A TOBT input must be at least the present time.
- c) The TOBT revision can be made as often as desired until the TSAT has been issued (40 minutes prior to TOBT).
- d) After the TSAT has been issued, the TOBT can only be revised not more than 5 times to ensure a stable operation.
- e) New TOBT must differ by at least 5 minutes (+/-5 minutes) from the latest input TOBT to protect a stable Pre-Departure Sequence.

3.2.4 Flights with Calculated Take-Off Time (CTOT)

Flights with CTOT will usually take priority when calculating TSATs in order to minimize potential CTOT delay.

3.2.5 TOBT Deletion

- a) TOBT can be deleted by users with permission to input/revise the TOBT.
- b) If the TOBT is deleted, the TSAT is automatically deleted.
- c) The TOBT has to be deleted in the following cases:
 - TOBT is unknown (e.g. technical problems with the aircraft), or
 - The permitted number of TOBT revision (5 times) after the generation of the TSAT has been exceeded.
- d) If a new TOBT is known, the process shall continue and the person responsible for the the TOBT has to enter a new TOBT.

3.2.6 TOBT Reporting Channels

The TOBT is reported or updated by the following ways:

- iDEP Web-based Application (<http://www.aerothai.aero>)
- SMS via digital trunked radio system
- Mobile Application

3.3 Target Start-Up Approval Time (TSAT) Procedures

3.3.1 General

The TSAT is the target time for start-up approval calculated by iDEP system based on the TOBT input from the airlines and operational constraints. The TSAT is calculated based on the following key parameters:

- Target Off-Block Time (TOBT)
- Calculated Take-Off Time (CTOT)
- Operational Capacity
- Variable Taxi Time (VTT)
- Parking Stand
- Departure Runway

VTBS/BKK

JEPPESSEN

BANGKOK, THAILAND

SUVARNABHUMI INTL

11 NOV 22

20-1P26

AIRPORT BRIEFING

AIRPORT COLLABORATIVE DECISION MAKING (A-CDM) AT SUVARNABHUMI INTL AIRPORT (CONTD)

3.3.2 TSAT Distribution

3.3.2.1 The TSAT is displayed/distributed 40 minutes prior to the TOBT.

3.3.2.2 After TSAT has been distributed, the TOBT can only be revised not more than 5 times to ensure a stable sequence and CTOT allocation.

3.3.2.3 Subsequent TOBT revision triggers a recalculation of TSAT. It should therefore be noted that an incorrect TOBT leads to disadvantages for further sequencing and/or CTOT allocation of regulated flights.

3.3.2.4 The TSAT may not be final and can be revised due to air traffic management.

3.3.3. TSAT Reporting Channels

3.3.3.1 The TSAT will be issued to airlines or person responsible for TOBT via the same reporting channels as the TOBT:

- iDEP Web-based Application (<http://www.aerothai.aero>)
- SMS via digital trunked radio system
- Mobile Application

3.3.3.2 The AO/GH is responsible for updating and ensuring that the pilot of a flight has the correct TOBT and TSAT prior to requesting ATC clearance.

3.4 Start-Up and Push Back Procedures

3.4.1 General

Start-up and push back approval are issued taking into account the TOBT and TSAT.

The sequence of the start-up and push back request is no longer a factor. The following rules apply:

3.4.2 Start-Up and Push Back Procedures

3.4.2.1 Pilot shall ensure that aircraft is ready for push back at TOBT.

3.4.2.2 After obtaining ATC clearance, pilot shall monitor defined ground control frequency in accordance with aircraft parking stand. If there is any change of TSAT, Ground Control will update the pilot as soon as possible.

3.4.2.3 Pilot shall contact Ground Control for start-up and push back within window (TSAT +/- 5 minutes). These three scenarios may occur:

1. Before TSAT window: Flight will be requested to call again when it is within the TSAT window.
2. Within TSAT window: Flight will be planned for outbound sequence and may expect start-up approval directly or within a few minutes depending on actual operational situation.
3. After TSAT window: The TSAT of the flight has expired. Flight will be denied start-up approval. Pilot has to contact its AO/GH to update the TOBT and shall contact ATC again when TOBT update has resulted in an updated TSAT.

3.4.2.4 Ground Control will issue start-up and push back clearance taking TSAT into account.

3.4.2.5 If a flight is unable to push back due to the aircraft being unready, TSAT will be cancelled. Pilot must notify the AO/GH to update the TOBT for a new TSAT.

VTBS/BKK

 JEPPESEN

BANGKOK, THAILAND

SUARNABHUMI INTL

11 NOV 22 (20-1P27)

AIRPORT BRIEFING

AIRPORT COLLABORATIVE DECISION MAKING (A-CDM) AT SUARNABHUMI INTL AIRPORT (CONTD)

4. A-CDM IN ADVERSE CONDITION

4.1 Adverse Conditions consist of collaborative management of the capacity of an airport during periods of predicted or unpredicted reduction of airport capacity. The aim is to achieve a common situation awareness for the A-CDM partners, including better information for the passengers, in anticipation of a disruption and expeditious recovery after the disruption.

4.2 In case of adverse conditions or any circumstances where predicted or unpredicted reduction of airport capacity may be expected, the following procedures shall be applied:

4.2.1 The pilot shall contact Ground Control for start-up and push back at TSAT +/- 5 minutes.

4.2.2 If there is any change of TSAT, Ground control will update the pilot accordingly.

5. NON A-CDM Operation

5.1 In case of unavailability or maintenance of iDEP system, TSAT will not be provided and Non A-CDM Operation shall be performed.

5.2 During period of Non A-CDM Operation, pilot shall request for ATC clearance when the aircraft is ready for pushback. ATC will then issue start-up/pushback clearance on a first-come-first-serve basis.

5.3 To minimize taxi-out delay and reduce fuel consumption, Gate Hold Procedures for departing aircraft may be implemented. Details are as follows:

5.3.1 When the occurrence of more than four departing aircraft bunching at the runway holding position is anticipated, an Expected Pushback Time (EPT) will be issued.

5.3.2 An EPT is issued to subsequent departing aircraft which is ready for pushback.

5.3.3 The determination of EPT will take into account an aircraft parking stand as well as taxi time to runway-in-use holding position.

5.3.4 When an EPT is issued, pilots are required to monitor on a relevant ground control frequency for possible updates of EPT.

5.3.5 When a departing aircraft is occupying a gate that has been assigned to an arriving aircraft, the departing aircraft may be instructed by ground control to push back onto the taxiway without engine start-up to allow the arriving aircraft to taxi in. An Expected Taxi Time will be provided accordingly.

CHANGES: ANREN, DULEM and NUGPA transitions added. BATOK transition removed. AIRWAYS L-880, M-633, N-506 and P-629 added. JEPPESEN BANGKOK, THAILAND .RNAV STAR. 2 OCT 20 20-2 EFF 8 Oct.

D-ATIS 133.6	Apt Elev 5	Alt Set: hPa Trans level: FL130
------------------------	----------------------	------------------------------------

1. RNAV1 required. 2. GNSS or DME/DME/IRU required. 3. RADAR required.
4. For non-RNAV equipped aircraft, pilot shall inform ATC in order to get RADAR guidance. 5. Pilot should plan for possible descent as depicted on STAR, actual descent clearance will be given by ATC. 6. If unable to comply with flight restrictions, advise ATC immediately.

**DOLNI3C [DOLN3C], EASTE3C [EAST3C]
LEBIM3C [LEBI3C]
RNAV ARRIVALS
(RWYS 19L/R)**

**SPEED: MAX 250 KT AT OR BELOW
10000 UNLESS OTHERWISE AUTHORIZED BY ATC**

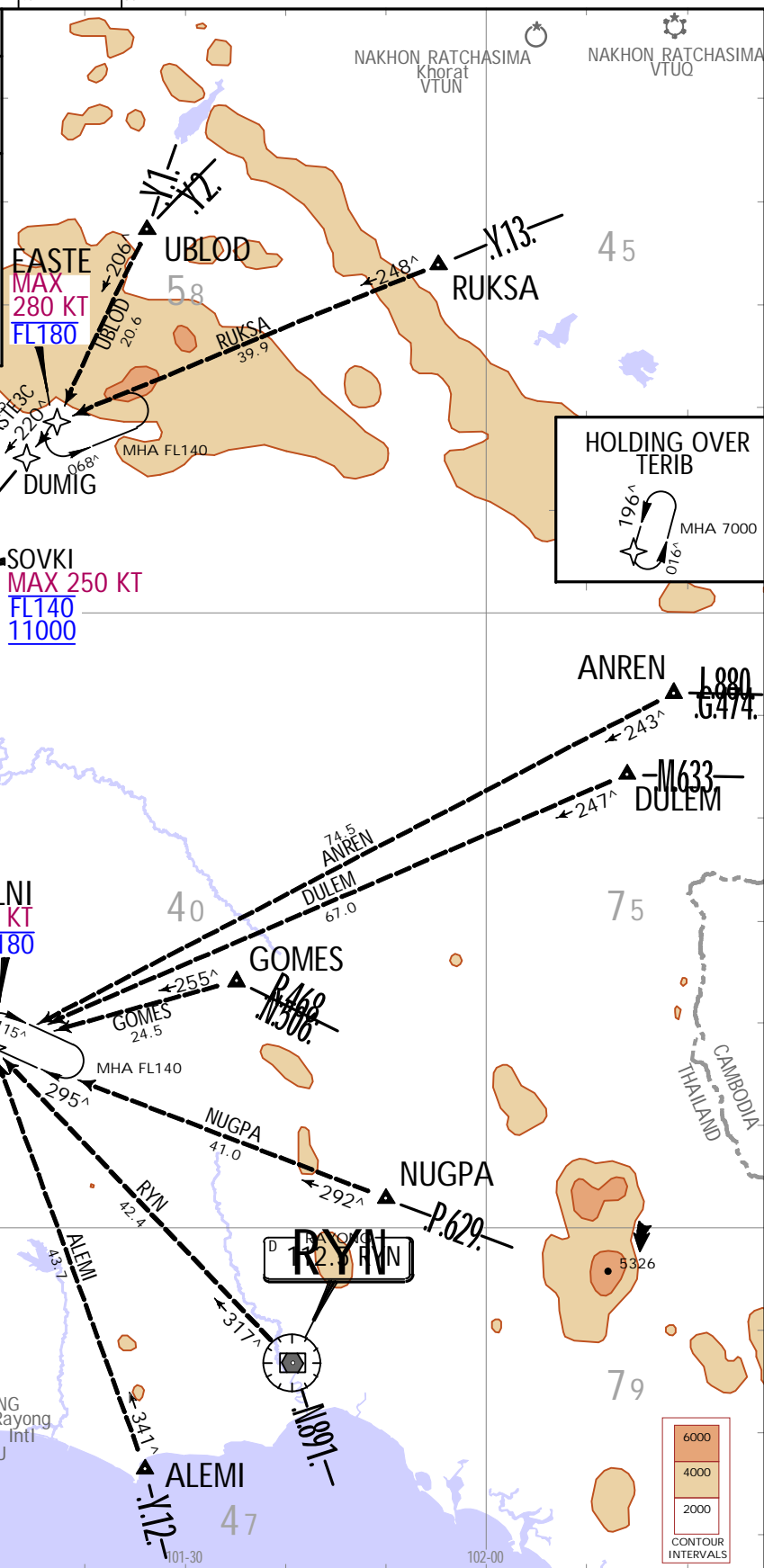
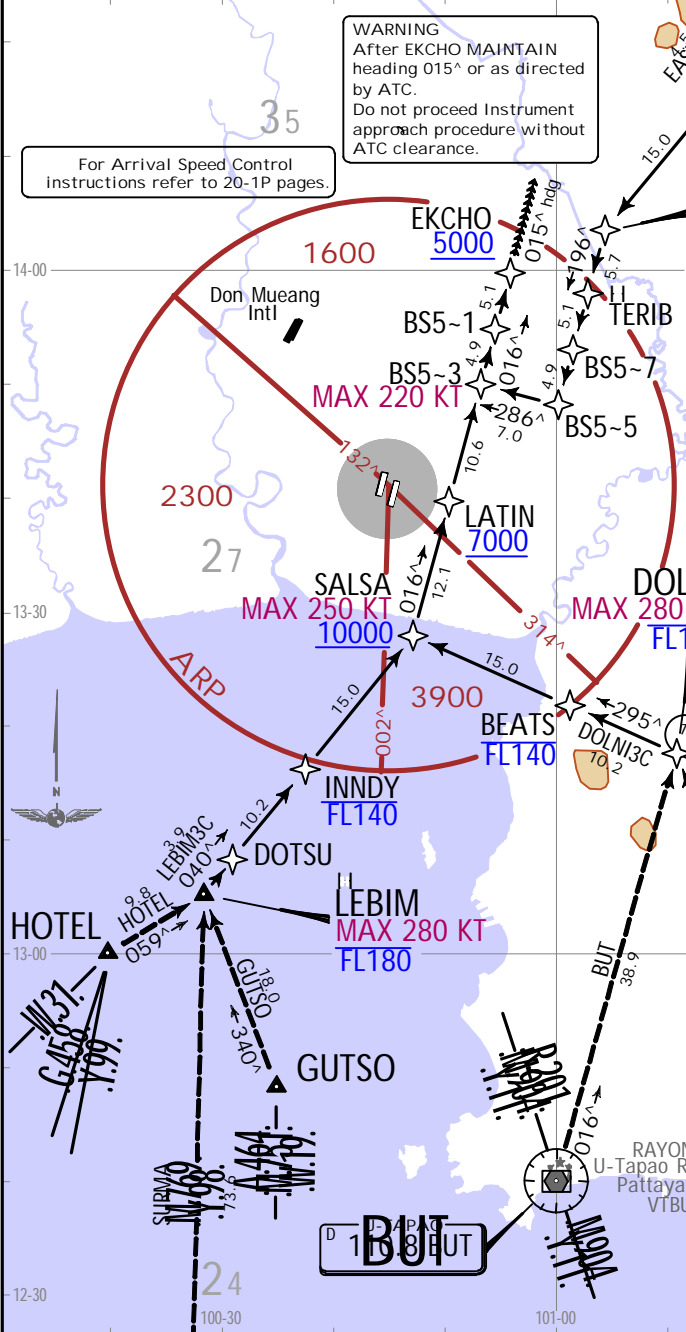

NOT TO SCALE

SURMA

M769
M771
M772
M773
M774
M775
M776
M777
M778
M779
M780
M781
M782
M783
M784
M785
M786
M787
M788
M789
M790
M791
M792
M793
M794
M795
M796
M797
M798
M799
M800

HOLDING OVER LEBIM

360°
180°

MHA FL140

- LOST COMMS
1. Set the aircraft transponder to mode A/C code 7600.
 2. Proceed according to the STAR route to the termination point EKCHO, descend in accordance with the published all speed and altitude restrictions of the relevant STAR procedure, then, after passing EKCHO fly heading 015° and MAINTAIN altitude 6000 for the next 10 NM, then turn LEFT and descend to 2000 and carry out the appropriate ILS approach procedure.
 3. When an arriving aircraft is being RADAR vectored, if no transmissions are heard on the frequency in use for a period of two minutes, a radio frequency check is to be made. If the radio frequency check indicates a radio communication failure, pilot should proceed in the most direct manner possible to rejoin the STAR procedure appropriate to its ATS route and landing direction and then comply with the procedures in item 2. above.

**DOLNI3C [DOLN3C]
EASTE3C [EAST3C]
LEBIM3C [LEBI3C]
RNAV ARRIVALS
(RWYS 19L/R)**

VTBS/BKK
SUVARNABHUMI INTL
JEPPESEN BANGKOK, THAILAND .RNAV STAR. 2 OCT 20 20-2 EFF 8 Oct.

JEPPesen BANGKOK, THAILAND
 SUVARNABHUMI INTL
 30 NOV 18 (20-2B) .Eff. 6. Dec. .RNAV .STAR.

D-ATIS 133.6
 Apt Elev 5
 Alt Set: hPa
 Trans level: FL130

1. RNAV1 required. 2. GNSS or DME/DME/IRU required. 3. RADAR required.
 4. For non-RNAV equipped aircraft, pilot shall inform ATC in order to get RADAR guidance. 5. Pilot should plan for possible descent as depicted on STAR, actual descent clearance will be given by ATC. 6. If unable to comply with flight restrictions, advise ATC immediately.

**NORTA3C [NORT3C]
 WILLA3C [WILA3C]
 RNAV ARRIVALS
 (RWYS 19L/R)
 .SPEED: MAX 250 KT AT OR BELOW
 10000 UNLESS OTHERWISE
 AUTHORIZED BY ATC**

COMMS ▶ LOST COMMS ▶ LOST COMMS ▶ LOST COMMS ▶ LOST COMMS

1. Set the aircraft transponder to mode A/C code 7600.
2. Proceed according to the STAR route to the termination point WALTZ, descend in accordance with the published all speed and altitude restrictions of the relevant STAR procedure, then, after passing WALTZ fly heading 015° and MAINTAIN altitude 6000 for the next 10 NM, then turn RIGHT and descend to 2000 and carry out the appropriate ILS approach procedure.
3. When an arriving aircraft is being RADAR vectored, if no transmissions are heard on the frequency in use for a period of two minutes, a radio frequency check is to be made. If the radio frequency check indicates a radio communication failure, pilot should proceed in the most direct manner possible to rejoin the STAR procedure appropriate to its ATS route and landing direction and then comply with the procedures in item 2. above.

▶ LOST COMMS ▶ LOST COMMS ▶ LOST COMMS ▶ LOST COMMS ▶ LOST COMMS

HOLDING OVER NORTA
 MHA FL140

HOLDING OVER WILLA
 MHA FL140

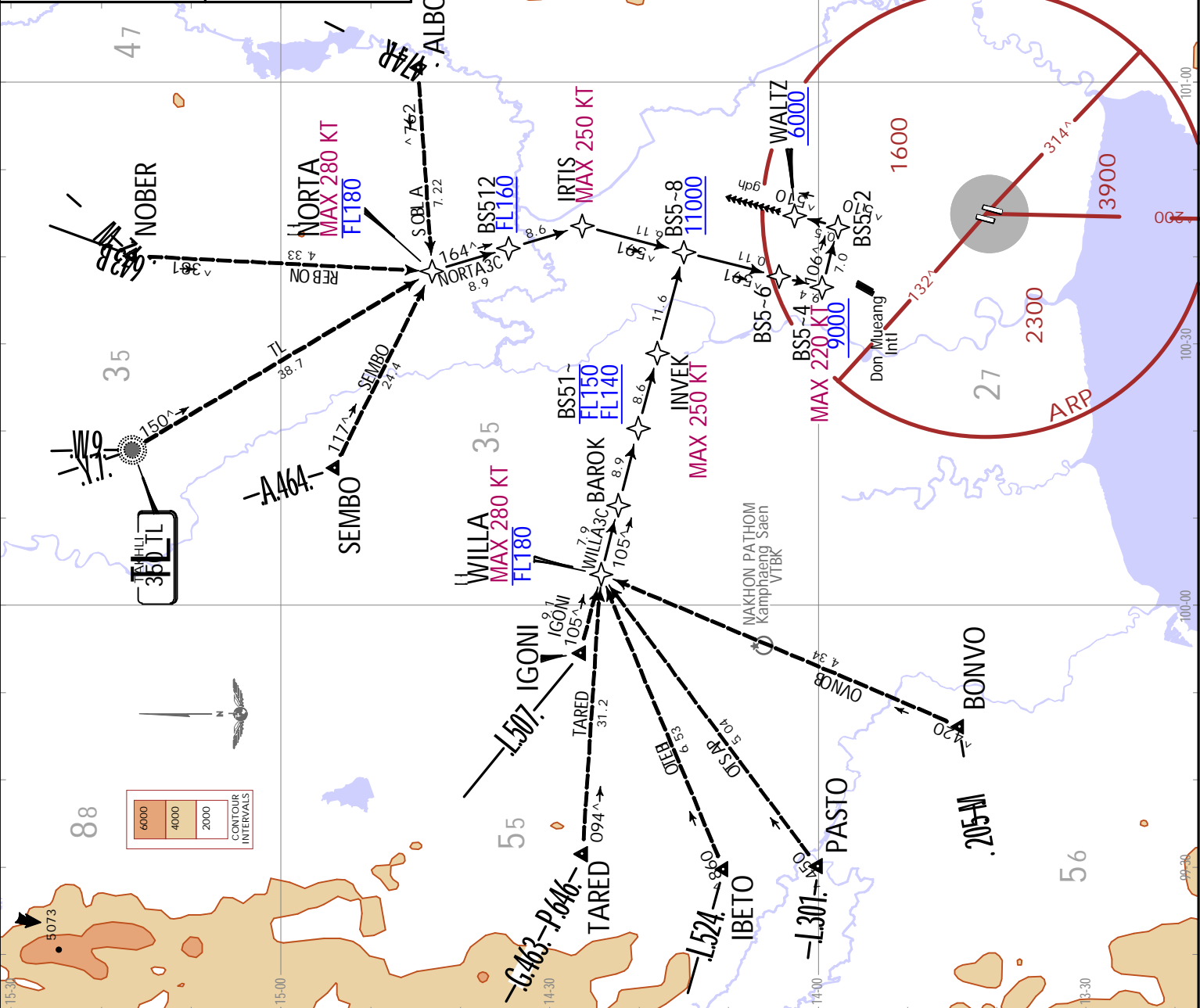

VTBS/BKK
 SUVARNABHUMI INTL

BANGKOK, THAILAND .RNAV.STAR	D-ATIS 133.6	Apt Elev 5	Alt Set: hPa Trans level: FL130
1. RNAV1 required. 2. GNSS or DME/DME/IRU required. 3. RADAR is required. 4. For non-RNAV equipped aircraft, pilot shall inform ATC in order to get RADAR guidance. 5. Pilot should plan for possible descent as depicted on STAR, actual descent clearance will be given by ATC. 6. If unable to comply with flight restrictions, advise ATC immediately.			
NORTA3D [NORT3D] WILLA3D [WILA3D] RNAV ARRIVALS (RWYS 01L/R) .SPEED: MAX 250 KT AT OR BELOW 10000 UNLESS OTHERWISE AUTHORIZED BY ATC			
COMMS ► LOST COMMS ► LOST COMMS ► LOST COMMS ► LOST COMMS 1. Set the aircraft transponder to mode A/C code 7600. 2. Proceed according to the STAR route to the termination point WOCAL, descend in accordance with the published all speed and altitude restrictions of the relevant STAR procedure, then, after passing WOCAL fly heading 195° and MAINTAIN altitude 6000 for the next 10 NM, then turn LEFT and descend to 2000 and carry out the appropriate ILS approach procedure. 3. When an arriving aircraft is being RADAR vectored, if no transmissions are heard on the frequency in use for a period of two minutes, a radio frequency check is to be made. If the radio frequency check indicates a radio communication failure, pilot should proceed in the most direct manner possible to rejoin the STAR procedure appropriate to its ATS route and landing direction and then comply with the procedures in item 2. above.			

HOLDING OVER NORTA MHA FL140 	HOLDING OVER WILLA MHA FL140
--	--

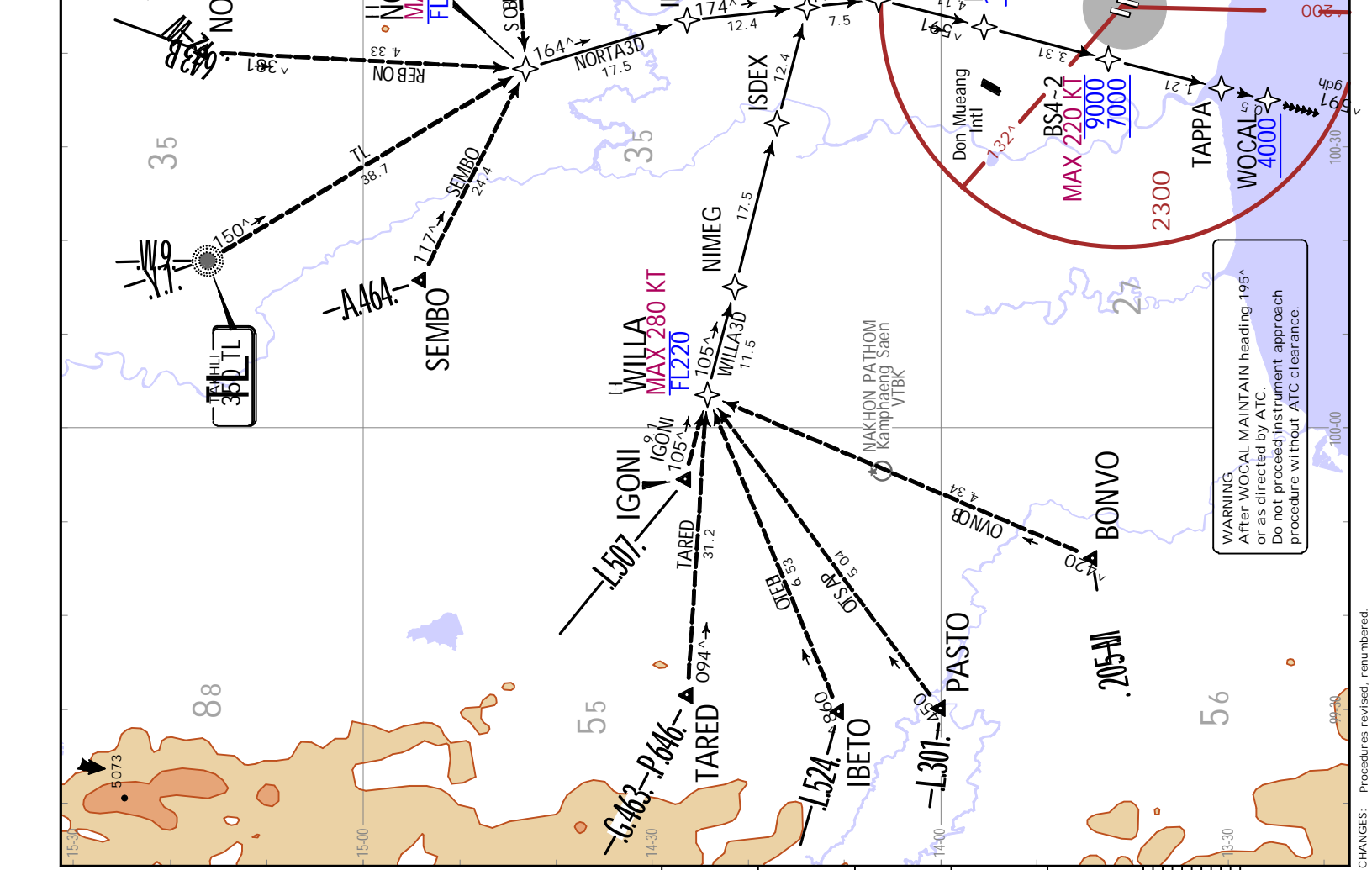

For Arrival Speed Control instructions refer to 20-1P pages.

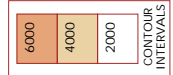

WARNING
 After WOCAL MAINTAIN heading 195° or as directed by ATC.
 Do not proceed instrument approach procedure without ATC clearance.

JEPPESEN BANGKOK, THAILAND
 30 NOV 18 (20-3B) .Eff.6.Dec. .RNAV.SID.

SUVARNABHUMI
 Departure
 119.25
 Apt Elev
 5
 Trans alt: 11000

1. RNAV1 required. 2. GNSS or DME/DME/IRU required. 3. RADAR required.
 4. For non-RNAV equipped aircraft, pilot shall inform ATC in order to get RADAR guidance.
 5. Pilot should plan for possible climb as depicted on SID, actual climb clearance will be given by ATC.
 6. If unable to comply with flight restrictions, advise ATC when aircraft commences to pushback or taxi to the holding point for departure.
 7. Initial climb clearance 6000 or as directed by ATC.

ALBOS3J [ALB03J]
 NOBER3J [NOB03J]
 NUNLI3J [NUNL3J]
 SEMBO3J [SEMB03J]
 TANGO3J [TANG3J], TL3J [TL3J]
 RNAV DEPARTURES
 (RWY 19L)

**.SPEED: MAX 250 KT AT OR BELOW
 10000 UNLESS OTHERWISE
 AUTHORIZED BY ATC**

These SIDs require a minimum climb gradient.
 NOBER3J, NUNLI3J, SEMBO3J, TANGO3J, TL3J:
 340 per NM (5.6%) until passing FL140 for airspace restrictions only.

Gnd speed-KT	75	100	150	200	250	300
340 per NM	425	567	850	1133	1417	1700

LOST COMMS
 1. Set the aircraft transponder to mode A/C code 7600.
 2. Comply with the last acknowledged clearance up to the next reporting point in the SID, then climb to the flight planned cruising level in accordance with the published all speed and altitude restrictions of the relevant SID procedure. Thereafter comply with the flight planned routing and level.
 3. When a departing aircraft is being RADAR vectored, if no transmissions are heard on the frequency in use for a period of two minutes, a radio frequency check is to be made. If the radio frequency check indicates a radio communication failure, the pilot shall MAINTAIN the last assigned heading, speed and level, or minimum flight altitude if higher.
 After a period of two minutes, the flight shall rejoin in the most direct manner possible to the route or the flight plan route no later than the next significant point. Thereafter comply with the flight planned routing and level.

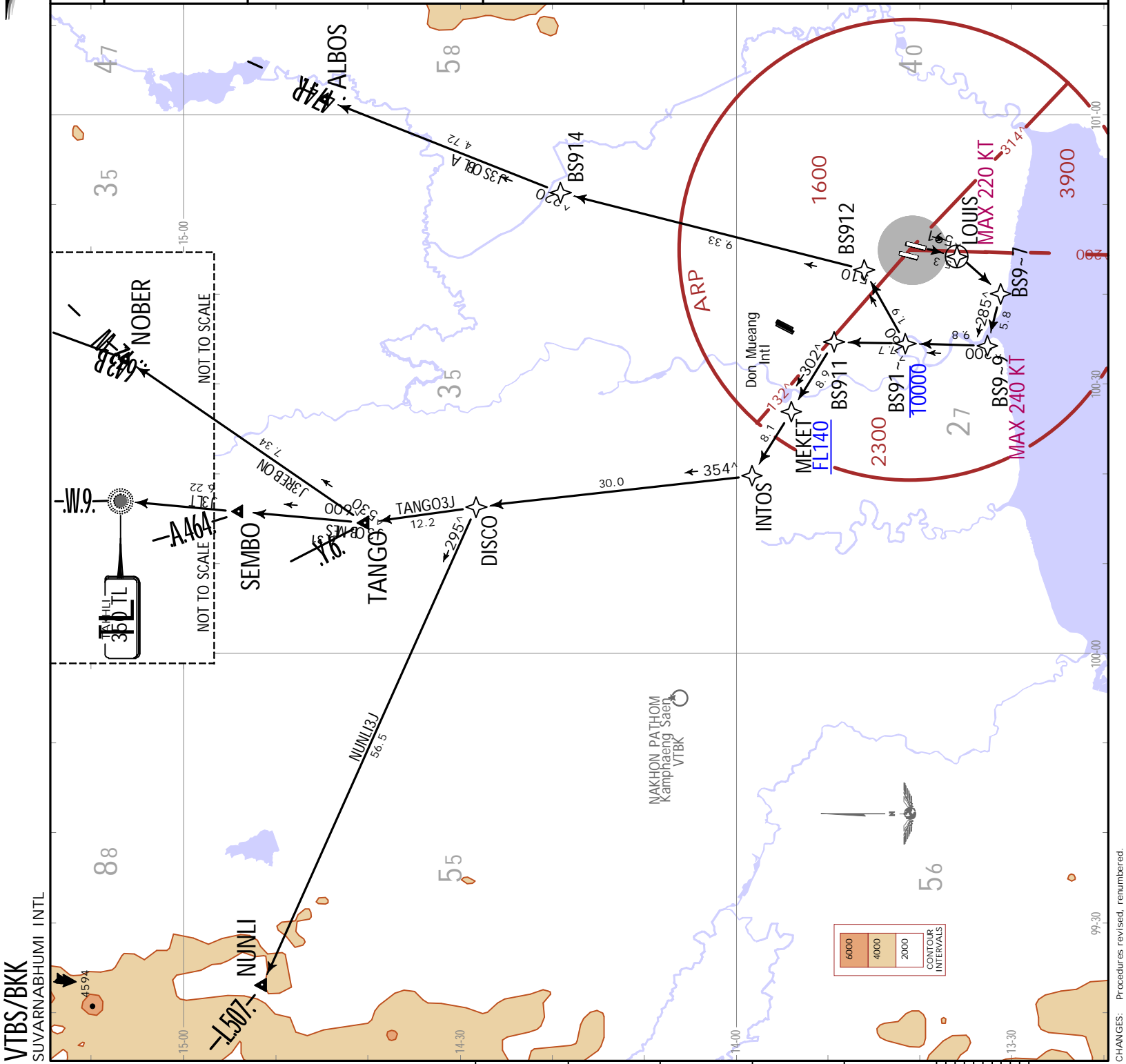

BANGKOK, THAILAND
.RNAV.SID.

VTBS/BKK
 SUVARNABHUMI INTL

JEPPESEN
 30 NOV 18 (20-3C) . Eff. 6. Dec.

SUVARNABHUMI
 Departure
 119.25

Apt Elev
 5

Trans alt: 11000

1. RNAV1 required. 2. GNSS or DME/DME/IRU required. 3. RADAR required.
 4. For non-RNAV equipped aircraft, pilot shall inform ATC in order to get RADAR guidance.
 5. Pilot should plan for possible climb as depicted on SID, actual climb clearance will be given by ATC.
 6. If unable to comply with flight restrictions, advise ATC when aircraft commences to pushback or taxi to the holding point for departure.
 7. Initial climb clearance 6000 or as directed by ATC.

ALBOS3K [ALB03K]
NOBER3K [NOBE3K]
NUNL13K [NUNL3K]
SEMBO3K [SEMB3K]
TANGO3K [TANG3K] TL3K [TL3K]
RNAV DEPARTURES
(RWY 01R)

.SPEED: MAX 250 KT AT OR BELOW 10000 UNLESS OTHERWISE AUTHORIZED BY ATC

These SIDs require minimum climb gradients for airspace restrictions only.

ALBOS3K: 346 per NM (5.7%) until passing FL160.
 NOBER3K, NUNL13K, SEMBO3K, TANGO3K, TL3K: 273 per NM (4.5%) until passing FL140.

Gnd speed-KT	75	100	150	200	250	300
273 per NM	341	455	683	910	1138	1365
346 per NM	433	577	865	1153	1442	1730

LOST COMMS ▼ LOST COMMS ▼ LOST COMMS ▼ LOST COMMS ▼ LOST COMMS

1. Set the aircraft transponder to mode A/C code 7600.
2. Comply with the last acknowledged clearance up to the next reporting point in the SID, then climb to the flight planned cruising level in accordance with the published all speed and altitude restrictions of the relevant SID procedure. Thereafter comply with the flight planned routing and level.
3. When a departing aircraft is being RADAR vectored, if no transmissions are heard on the frequency in use for a period of two minutes, a radio frequency check is to be made. If the radio frequency check indicates a radio communication failure, the pilot shall MAINTAIN the last assigned heading, speed and level, or minimum flight altitude if higher. After a period of two minutes, the flight shall rejoin in the most direct manner possible to rejoin the SID procedure appropriate to its ATS route or the flight plan route no later than the next significant point. Thereafter comply with the flight planned routing and level.

▲ LOST COMMS ▲ LOST COMMS ▲ LOST COMMS ▲ LOST COMMS ▲ LOST COMMS

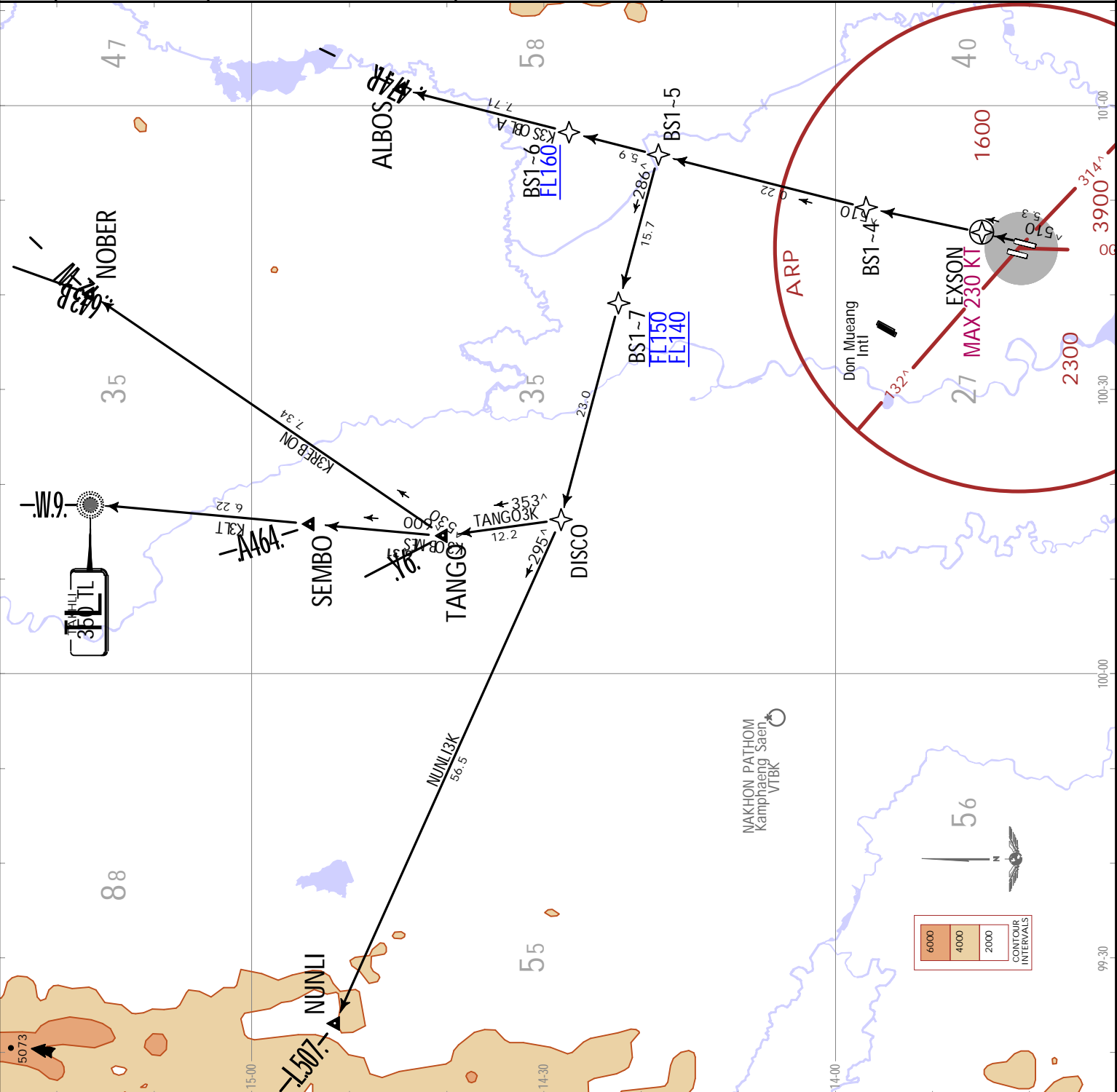

VTBS/BKK
SUVARNABHUMI INTL

JEPPESEN BANGKOK, THAILAND
SUVARNABHUMI
Departure
119.25
Apt Elev
5
Trans alt: 11000
2 OCT 20 (20-3D) Eff: 8 Oct. .RNAV.SID.

VTBS/BKK
SUVARNABHUMI INTL

1. RNAV1 required. 2. GNSS or DME/DME/IRU required. 3. RADAR required.
4. For non-RNAV equipped aircraft, pilot shall inform ATC in order to get RADAR guidance.
5. Pilot should plan for possible climb as depicted on SID, actual climb clearance will be given by ATC.
6. If unable to comply with flight restrictions, advise ATC when aircraft commences to pushback or taxi to the holding point for departure.
7. Initial climb clearance 6000 or as directed by ATC.

1. Set the aircraft transponder to mode A/C code 7600.
2. Comply with the last acknowledged clearance up to the next reporting point in the SID, then climb to the flight planned cruising level in accordance with the published all speed and altitude restrictions of the relevant SID procedure. Thereafter comply with the flight planned routing and level.
3. When a departing aircraft is being RADAR vectored, if no transmissions are heard on the frequency in use for a period of two minutes, a radio frequency check is to be made. If the radio frequency check indicates a radio communication failure, the pilot shall MAINTAIN the last assigned heading, speed and level, or minimum flight altitude if higher. After a period of two minutes, the flight shall rejoin in the most direct manner possible to rejoin the SID procedure appropriate to its ATS route or the flight plan route no later than the next significant point. Thereafter comply with the flight planned routing and level.

BONVO3G | **BONV3G**
PASTO3G | **PAST3G**
ROBKA3G | **ROBK3G**
TARED3G | **TARE3G**
UPKUP3G | **UPKU3G**
RNAV DEPARTURES
(RWY 19R)

.SPEED: MAX 250 KT AT OR BELOW 10000 UNLESS OTHERWISE AUTHORIZED BY ATC

BONVO3G, PASTO3G, TARED3G: These SIDs require a minimum climb gradient of 340 per NM (5.6%) until passing FL140 for airspace restrictions only.

Gnd speed-KT	75	100	150	200	250	300
340 per NM	425	567	850	1133	1417	1700

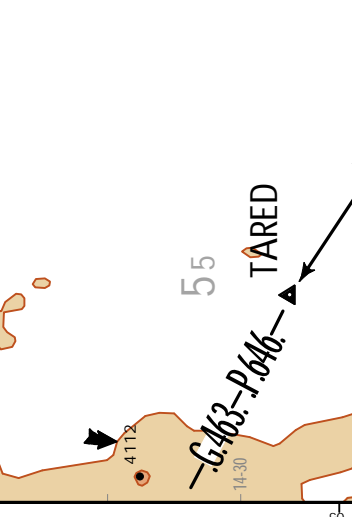
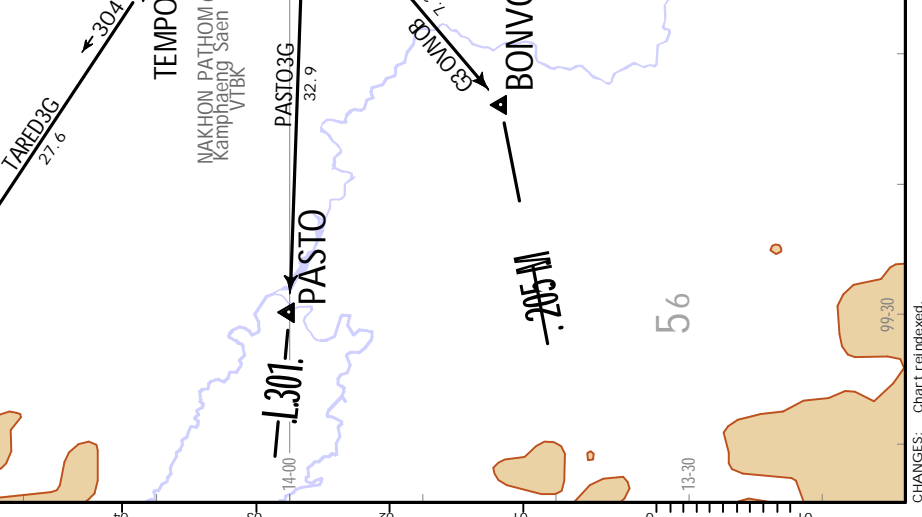
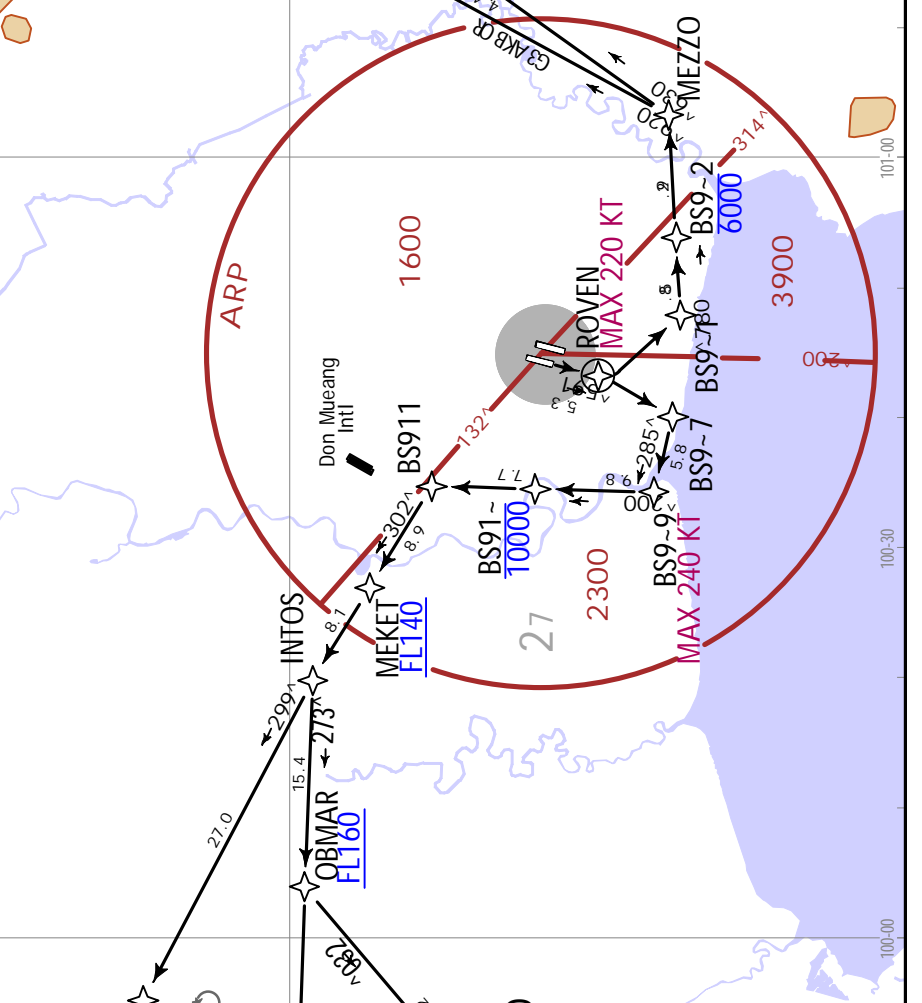
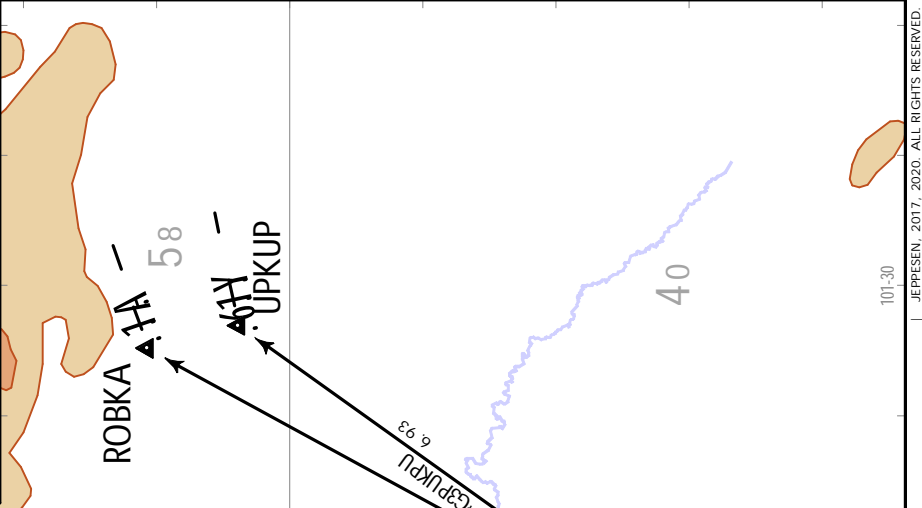

1. RNAV1 required. 2. GNSS or DME/DME/IRU required. 3. RADAR required.
4. For non-RNAV equipped aircraft, pilot shall inform ATC in order to get RADAR guidance.
5. Pilot should plan for possible climb as depicted on SID, actual climb clearance will be given by ATC.
6. If unable to comply with flight restrictions, advise ATC when aircraft commences to pushback or taxi to the holding point for departure.
7. Initial climb clearance 6000 or as directed by ATC.

**BONVO3H [BONV3H]
PASTO3H [PAST3H]
ROBKA3H [ROBK3H]
TARED3H [TARE3H]
UPKUP3H [UPKU3H]
RNAV DEPARTURES
(RWY 01L)**

**.SPEED: MAX 250 KT AT OR BELOW
10000 UNLESS OTHERWISE
AUTHORIZED BY ATC**

1. Set the aircraft transponder to mode A/C code 7600.
2. Comply with the last acknowledged clearance up to the next reporting point in the SID, then climb to the flight planned cruising level in accordance with the published all speed and altitude restrictions of the relevant SID procedure. Thereafter comply with the flight planned routing and level.
3. When a departing aircraft is being RADAR vectored, if no transmissions are heard on the frequency in use for a period of two minutes, a radio frequency check is to be made. If the radio frequency check indicates a radio communication failure, the pilot shall MAINTAIN the last assigned heading, speed and level, or minimum flight altitude if higher. After a period of two minutes, the flight shall rejoin in the most direct manner possible to rejoin the SID procedure appropriate to its ATS route or the flight plan route no later than the next significant point. Thereafter comply with the flight planned routing and level.

These SIDs require minimum climb gradients for airspace restrictions only.

BONVO3H, PASTO3H, TARED3H: 322 per NM (5.3%) until passing 8000.
ROBKA3H, UPKUP3H: 273 per NM (4.5%) until passing VARIS.

Gnd speed-KT	75	100	150	200	250	300
273 per NM	341	455	683	910	1138	1365
322 per NM	402	537	805	1073	1342	1610

6000
4000
2000
CONTOUR INTERVALS

1. **Q**
2. **Q**
3. **Q**
4. **Q**
5. **Q**
6. **Q**
7. **Q**
8. **Q**
9. **Q**
10. **Q**
11. **Q**
12. **Q**
13. **Q**
14. **Q**
15. **Q**
16. **Q**
17. **Q**
18. **Q**
19. **Q**
20. **Q**
21. **Q**
22. **Q**
23. **Q**
24. **Q**
25. **Q**
26. **Q**
27. **Q**
28. **Q**
29. **Q**
30. **Q**
31. **Q**
32. **Q**
33. **Q**
34. **Q**
35. **Q**
36. **Q**
37. **Q**
38. **Q**
39. **Q**
40. **Q**
41. **Q**
42. **Q**
43. **Q**
44. **Q**
45. **Q**
46. **Q**
47. **Q**
48. **Q**
49. **Q**
50. **Q**
51. **Q**
52. **Q**
53. **Q**
54. **Q**
55. **Q**
56. **Q**
57. **Q**
58. **Q**
59. **Q**
60. **Q**
61. **Q**
62. **Q**
63. **Q**
64. **Q**
65. **Q**
66. **Q**
67. **Q**
68. **Q**
69. **Q**
70. **Q**
71. **Q**
72. **Q**
73. **Q**
74. **Q**
75. **Q**
76. **Q**
77. **Q**
78. **Q**
79. **Q**
80. **Q**
81. **Q**
82. **Q**
83. **Q**
84. **Q**
85. **Q**
86. **Q**
87. **Q**
88. **Q**
89. **Q**
90. **Q**
91. **Q**
92. **Q**
93. **Q**
94. **Q**
95. **Q**
96. **Q**
97. **Q**
98. **Q**
99. **Q**
100. **Q**

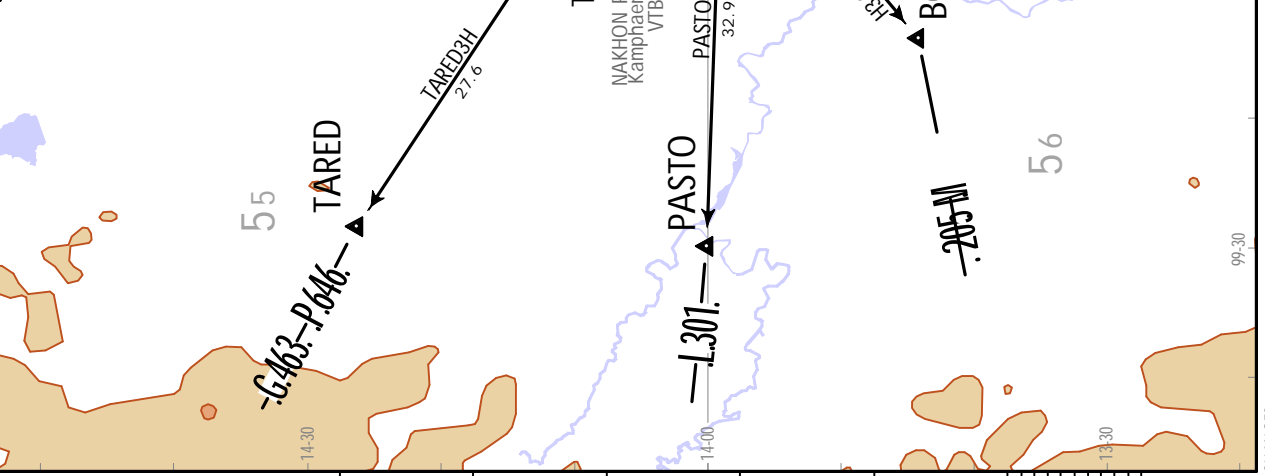

JEPPesen BANGKOK, THAILAND
SUVARNABHUMI INTL
.RNAV.SID.
 2 OCT 20 (20-3F) .Eff:8.Oct.

VTBS/BKK
SUVARNABHUMI INTL
 88
 55
 56
 99-30

SUVARNABHUMI
 Departure
119.25
 Apt Elev
5
 Trans alt: 11000

1. RNAV1 required. 2. GNSS or DME/DME/IRU required. 3. RADAR required.
 4. For non-RNAV equipped aircraft, pilot shall inform ATC in order to get RADAR guidance.
 5. Pilot should plan for possible climb as depicted on SID, actual climb clearance will be given by ATC.
 6. If unable to comply with flight restrictions, advise ATC when aircraft commences to pushback or taxi to the holding point for departure.
 7. Initial climb clearance 6000 or as directed by ATC.

1. Set the aircraft transponder to mode A/C code 7600.
 2. Comply with the last acknowledged clearance up to the next reporting point in the SID, then climb to the flight planned cruising level in accordance with the published all speed and altitude restrictions of the relevant SID procedure. Thereafter comply with the flight planned routing and level.
 3. When a departing aircraft is being RADAR vectored, if no transmissions are heard on the frequency in use for a period of two minutes, a radio frequency check is to be made. If the radio frequency check indicates a radio communication failure, the pilot shall MAINTAIN the last assigned heading, speed and level, or minimum flight altitude if higher. After a period of two minutes, the flight shall rejoin in the most direct manner possible to rejoin the SID procedure appropriate to its ATS route or the flight plan route no later than the next significant point. Thereafter comply with the flight planned routing and level.

BONVO3J [BONV3J]
PASTO3J [PAST3J]
ROBKA3J [ROBK3J]
TARED3J [TARE3J]
UPKUP3J [UPKU3J]
RNAV DEPARTURES (RWY 19L)
.SPEED: MAX 250 KT AT OR BELOW 10000 UNLESS OTHERWISE AUTHORIZED BY ATC

These SIDs require a minimum climb gradient:
 BONVO3J, PASTO3J, TARED3J: 340 per NM (5.6%) until passing FL140 for airspace restrictions only.

Grnd speed-KT	75	100	150	200	250	300
340 per NM	425	567	850	1133	1417	1700

ROBKA 1HA
 58
 40TH
 UPKUP

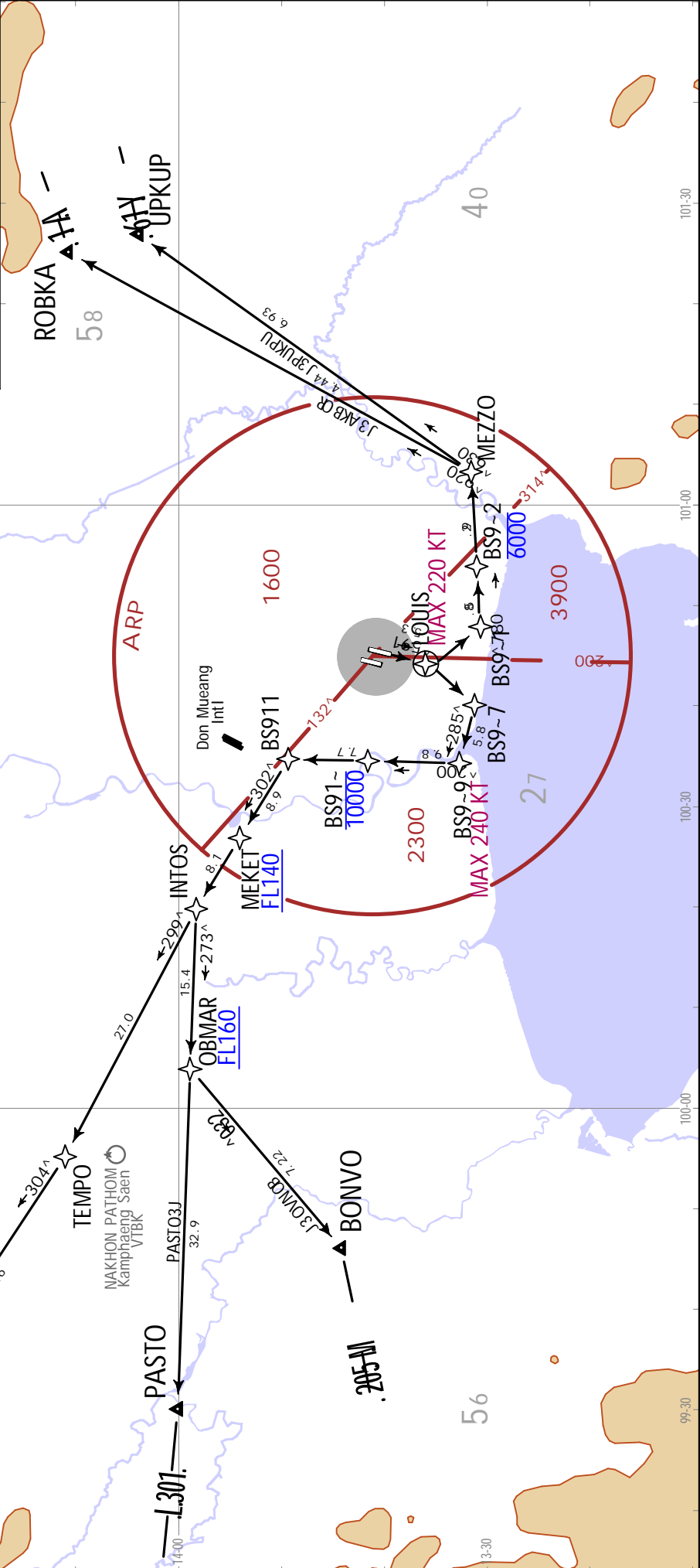

1. RNAV1 required. 2. GNSS or DME/DME/IRU required. 3. RADAR required.
4. For non-RNAV equipped aircraft, pilot shall inform ATC in order to get RADAR guidance.
5. Pilot should plan for possible climb as depicted on SID, actual climb clearance will be given by ATC.
6. If unable to comply with flight restrictions, advise ATC when aircraft commences to pushback or taxi to the holding point for departure.
7. Initial climb clearance 6000 or as directed by ATC.

BONVO3K BONV3K
PASTO3K PAST3K
ROBKA3K ROB3K
TARED3K TARE3K
UPKUP3K UPKU3K
RNAV DEPARTURES (RWY 01R)
.SPEED: MAX 250 KT AT OR BELOW 10000 UNLESS OTHERWISE AUTHORIZED BY ATC

1. Set the aircraft transponder to mode A/C code 7600.
2. Comply with the last acknowledged clearance up to the next reporting point in the SID, then climb to the flight planned cruising level in accordance with the published air speed and altitude restrictions of the relevant SID procedure. Thereafter comply with the flight planned routing and level.
3. When a departing aircraft is being RADAR vectored, if no transmissions are heard on the frequency in use for a period of two minutes, a radio frequency check is to be made. If the radio frequency check indicates a radio communication failure, the pilot shall MAINTAIN the last assigned heading, speed and level, or minimum flight altitude if higher. After a period of two minutes, the flight shall rejoin in the most direct manner possible to rejoin the SID procedure appropriate to its ATS route or the flight plan route no later than the next significant point. Thereafter comply with the flight planned routing and level.

These SIDs require minimum climb gradients.

BONVO3K, PASTO3K, TARED3K: 322 per NM (5.3%) until passing 8000 for airspace restrictions only.	75	100	150	200	250	300
ROBKA3K, UPKUP3K: 273 per NM (4.5%) until passing EXSON.	341	455	683	910	1138	1365
	402	537	805	1073	1342	1610

Gnd speed-KT
273 per NM
322 per NM

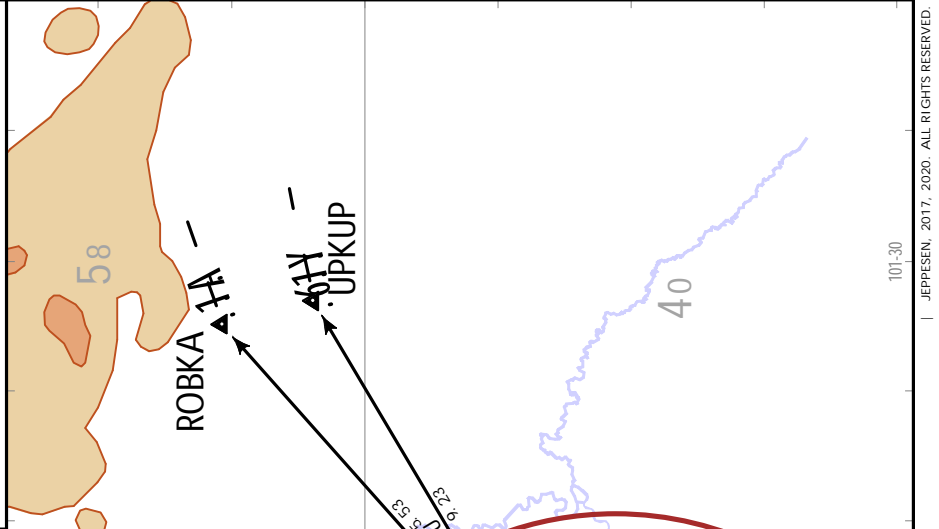
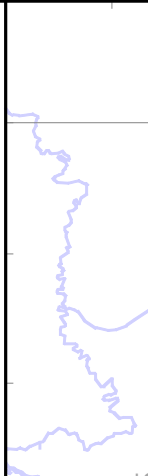

1. RNAV1 required. 2. GNSS or DME/DME/IRU required. 3. RADAR required. 4. For non-RNAV equipped aircraft, pilot shall inform ATC in order to get RADAR guidance. 5. Pilot should plan for possible climb as depicted on SID, actual climb clearance will be given by ATC. 6. If unable to comply with flight restrictions, advise ATC when aircraft commences to pushback or taxi to the holding point for departure. 7. Initial climb clearance 6000 or as directed by ATC.

These SIDs require minimum climb gradients.

BONVO3K, PASTO3K, TARED3K: 322 per NM (5.3%) until passing 8000 for airspace restrictions only.	75	100	150	200	250	300
ROBKA3K, UPKUP3K: 273 per NM (4.5%) until passing EXSON.	341	455	683	910	1138	1365
	402	537	805	1073	1342	1610

Gnd speed-KT
273 per NM
322 per NM

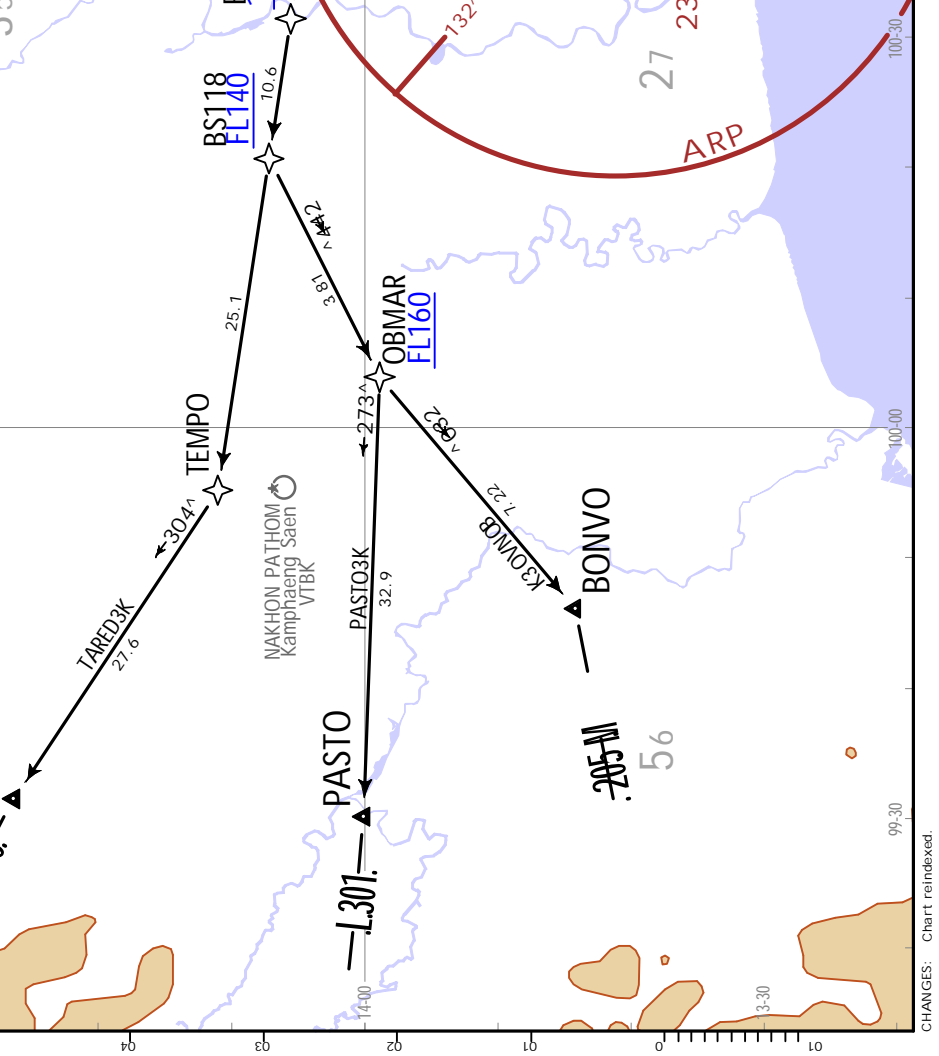

JEPPESEN BANGKOK, THAILAND
SUVARNABHUMI INTL
2 OCT 20 (20-3H) .EFF.8.Oct.
.RNAV.SID.

SUVARNABHUMI
Departure
119.25
Apt Elev
5
Trans alt: 11000

1. RNAV1 required. 2. GNSS or DME/DME/IRU required. 3. RADAR required.
4. For non-RNAV equipped aircraft, pilot shall inform ATC in order to get RADAR guidance.
5. Pilot should plan for possible climb as depicted on SID, actual climb clearance will be given by ATC.
6. If unable to comply with flight restrictions, advise ATC when aircraft commences to pushback or taxi to the holding point for departure.
7. Initial climb clearance 6000 or as directed by ATC.

DOSBU3G [DOSB3G]
GORSI3G [GORS3G]
KASNI3G [KASN3G]
KIGOB3G [KIGO3G]
REGOS3G [REGO3G]
RYN3G [RYN3G]
RNAV DEPARTURES (RWY 19R)

.SPEED: MAX 250 KT AT OR BELOW 10000 UNLESS OTHERWISE AUTHORIZED BY ATC

COMMS ► LOST COMMS ► LOST COMMS ► LOST COMMS ► LOST COMMS
1. Set the aircraft transponder to mode A/C code 7600.
2. Comply with the last acknowledged clearance up to the next reporting point in the SID, then climb to the flight planned cruising level in accordance with the published all speed and altitude restrictions of the relevant SID procedure. Thereafter comply with the flight planned routing and level.
3. When a departing aircraft is being RADAR vectored, if no transmissions are heard on the frequency in use for a period of two minutes, a radio frequency check is to be made. If the radio frequency check indicates a radio communication failure, the pilot shall MAINTAIN the last assigned heading, speed and level, or minimum flight altitude if higher. After a period of two minutes, the flight shall rejoin in the most direct manner possible to the route or the flight plan route no later than the next significant point. Thereafter comply with the flight planned routing and level.

LOST COMMS ► LOST COMMS ► LOST COMMS ► LOST COMMS ► LOST COMMS

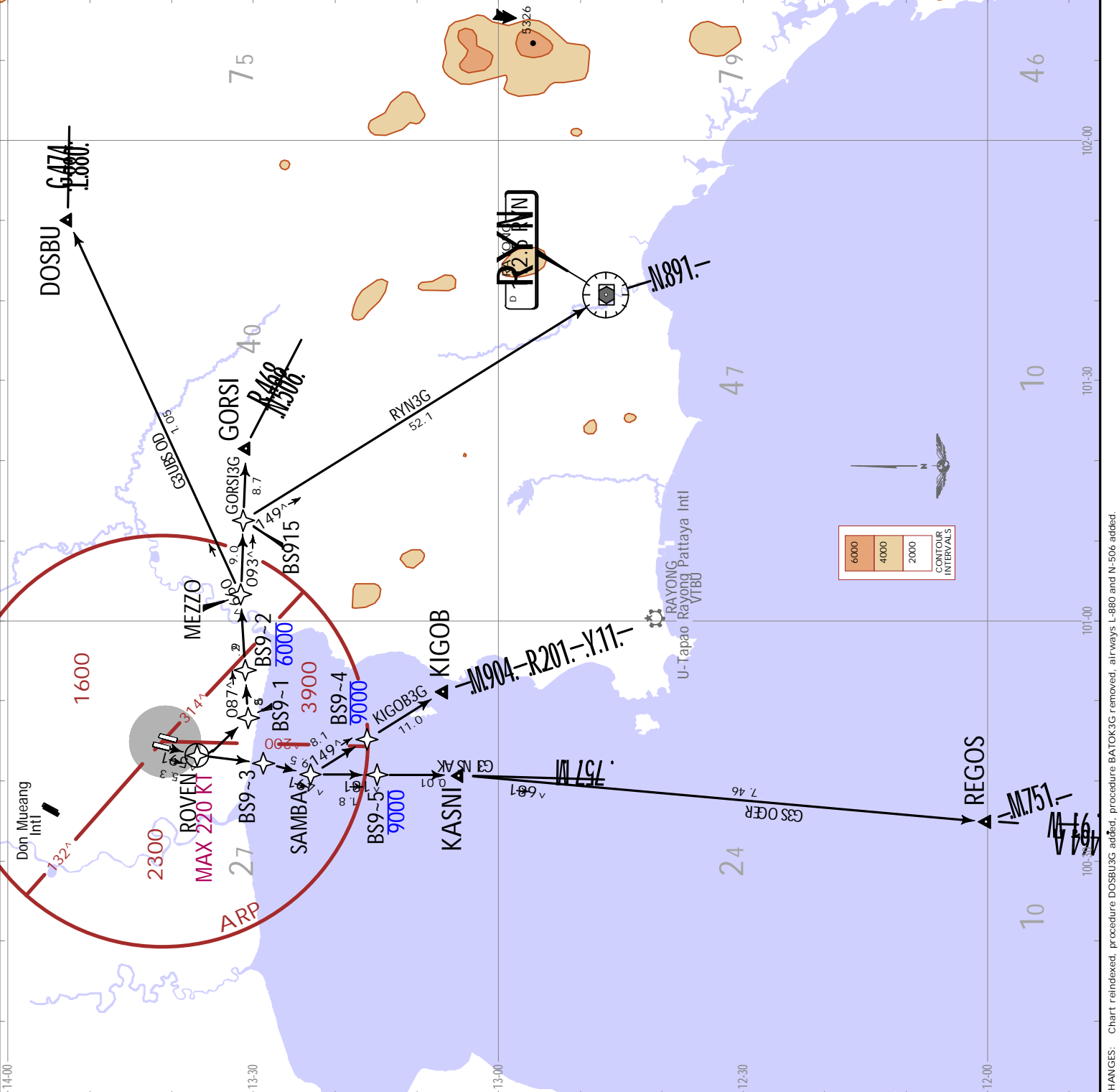

SUVARNABHUMI
Departure
119.25

Apt Elev
5

Trans alt: 11000

1. RNAV1 required. 2. GNSS or DME/DME/IRU required. 3. RADAR required.
4. For non-RNAV equipped aircraft, pilot shall inform ATC in order to get RADAR guidance.
5. Pilot should plan for possible climb as depicted on SID, actual climb clearance will be given by ATC.
6. If unable to comply with flight restrictions, advise ATC when aircraft commences to pushback or taxi to the holding point for departure.
7. Initial climb clearance 6000 or as directed by ATC.

DOSBU3J [DOSB3J]
GORS13J [GORS3J]
KASNI13J [KASIN3J]
KIGOB3J [KIGOB3J]
REGOS3J [REGO3J]
RYN13J [RYN3J]
RNAV DEPARTURES
(RWY 19L)

.SPEED: MAX 250 KT AT OR BELOW
10000 UNLESS OTHERWISE
AUTHORIZED BY ATC

LOST COMMS ▼ LOST COMMS ▼ LOST COMMS ▼ LOST COMMS ▼ LOST
LOST COMMS ▼ LOST COMMS ▼ LOST COMMS ▼ LOST COMMS ▼ LOST
LOST COMMS ▼ LOST COMMS ▼ LOST COMMS ▼ LOST COMMS ▼ LOST
LOST COMMS ▼ LOST COMMS ▼ LOST COMMS ▼ LOST COMMS ▼ LOST

1. Set the aircraft transponder to mode A/C code 7600.
2. Comply with the last acknowledged clearance up to the next reporting point in the SID, then climb to the flight planned cruising level in accordance with the published all speed and altitude restrictions of the relevant SID procedure. Thereafter comply with the flight planned routing and level.
3. When a departing aircraft is being RADAR vectored, if no transmissions are heard on the frequency in use for a period of two minutes, a radio frequency check is to be made. If the radio frequency check indicates a radio communication failure, the pilot shall MAINTAIN the last assigned heading, speed and level, or minimum flight altitude if higher. After a period of two minutes, the flight shall rejoin in the most direct manner possible to rejoin the SID procedure appropriate to its ATS route or the flight plan route no later than the next significant point. Thereafter comply with the flight planned routing and level.

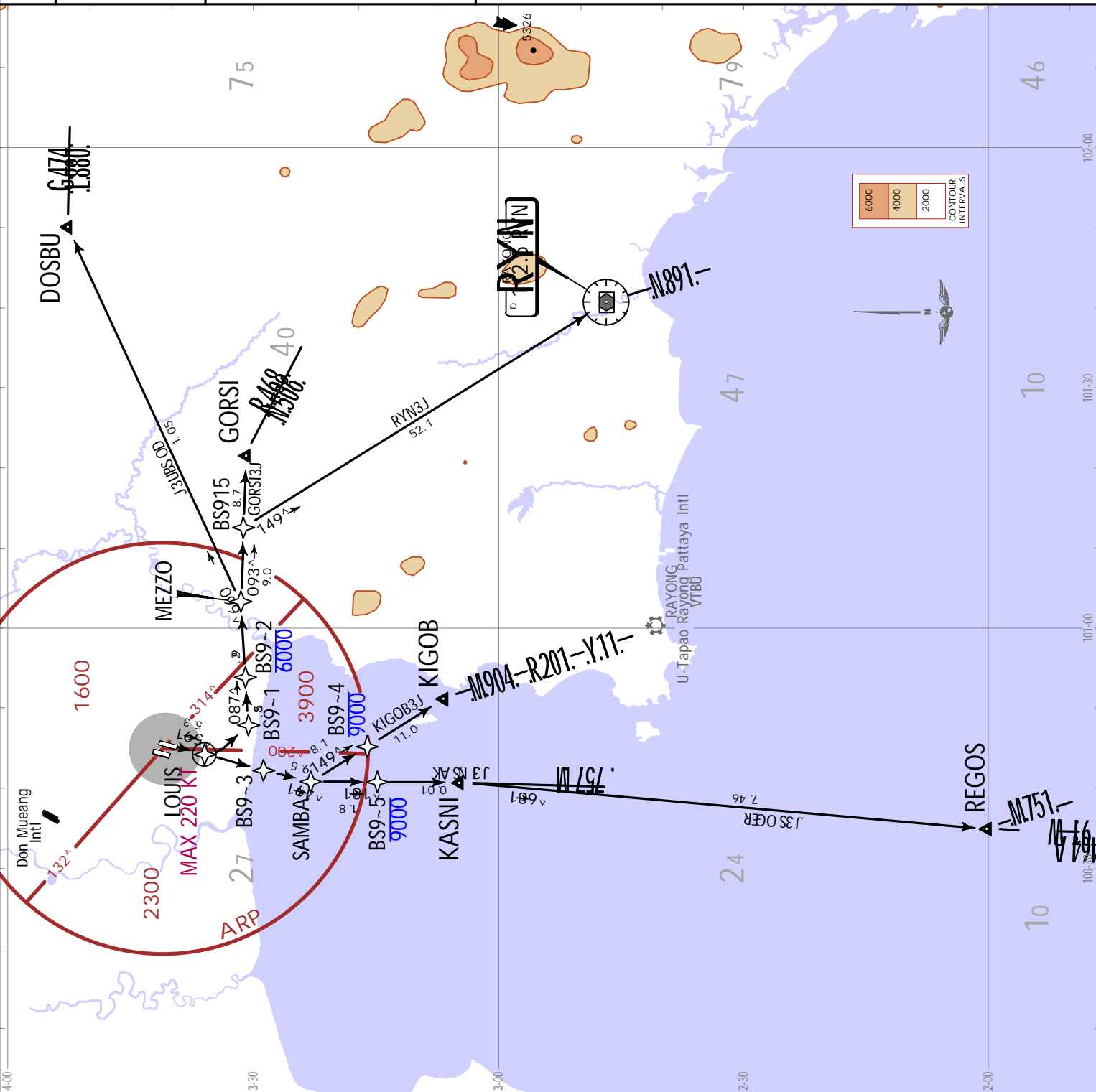

SUVARNABHUMI Departure	Apt Elev	Trans alt: 11000
119.25	5	

- RNAV1 required. 2. GNSS or DME/DME/IRU required. 3. RADAR required.
- For non-RNAV equipped aircraft, pilot shall inform ATC in order to get RADAR guidance.
- Pilot should plan for possible climb as depicted on SID, actual climb clearance will be given by ATC.
- If unable to comply with flight restrictions, advise ATC when aircraft commences to pushback or taxi to the holding point for departure.
- Initial climb clearance 6000 or as directed by ATC.

DOSBU3K [DOSB3K]
GORS13K [GORS3K]
KASNI3K [KASN3K]
KIGOB3K [KIGO3K]
REGOS3K [REGO3K]
RYN3K [RYN3K]
RNAV DEPARTURES (RWY 01R)

.SPEED: MAX 250 KT AT OR BELOW 10000 UNLESS OTHERWISE AUTHORIZED BY ATC

These SIDs require a minimum climb gradient of 273 per NM (4.5%) until passing EXSON.

Gnd speed-KT	75	100	150	200	250	300
273 per NM	341	455	683	910	1138	1365

- Set the aircraft transponder to mode A/C code 7600.
- Comply with the last acknowledged clearance up to the next reporting point in the SID, then climb to the flight planned cruising level in accordance with the published all speed and altitude restrictions of the relevant SID procedure. Thereafter comply with the flight planned routing and level.
- When a departing aircraft is being RADAR vectored, if no transmissions are heard on the frequency in use for a period of two minutes, a radio frequency check is to be made. If the radio frequency check indicates a radio communication failure, the pilot shall MAINTAIN the last assigned heading, speed and level, or minimum flight altitude if higher. After a period of two minutes, the flight shall rejoin in the most direct manner possible to rejoin the SID procedure appropriate to its ATS route or the flight plan route no later than the next significant point. Thereafter comply with the flight planned routing and level.

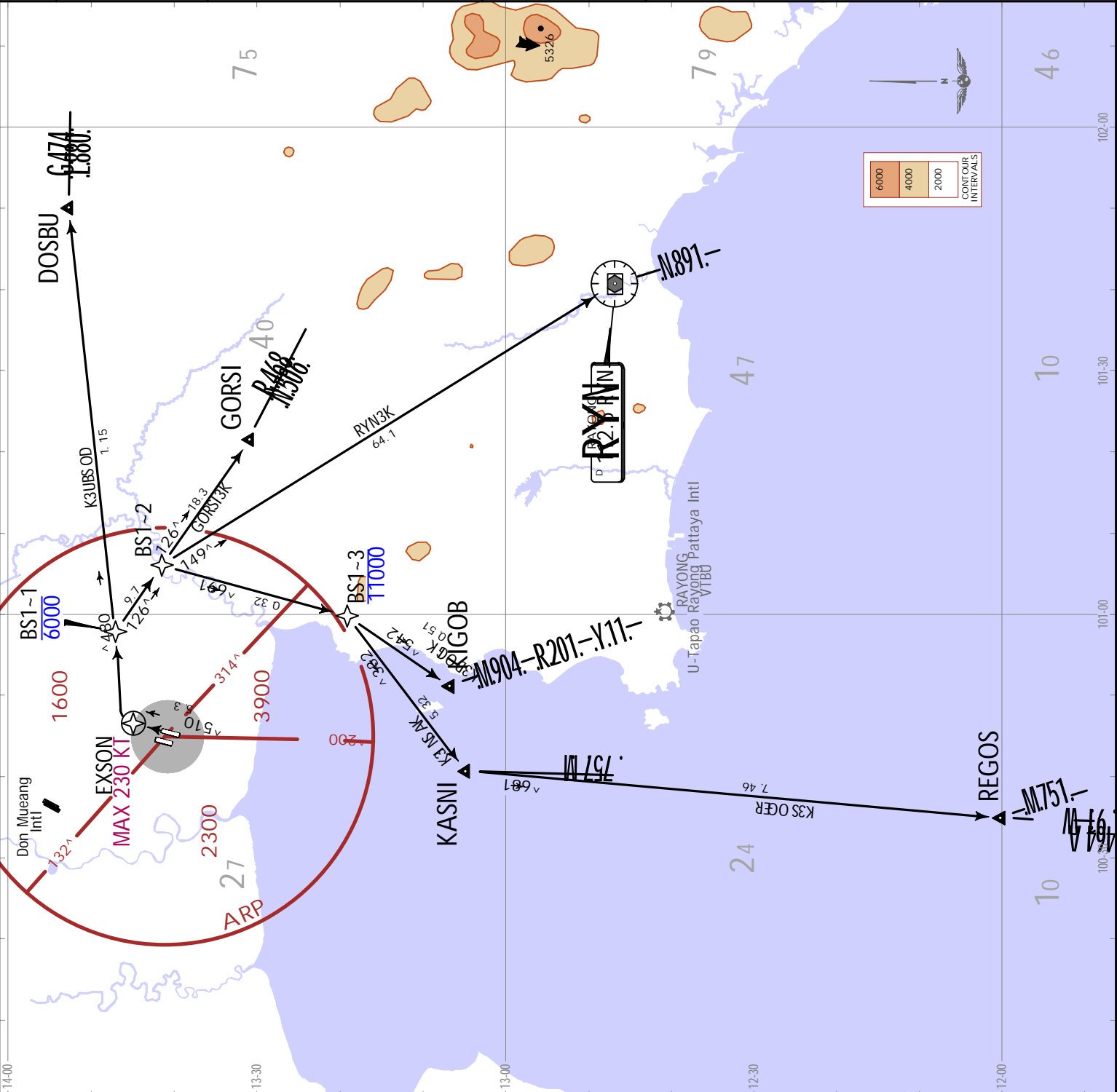

JEPPESEN
BANGKOK, THAILAND
.RNAV.SID.

VTBS/BKK
SUARNABHUMI INTL
30 NOV 18 (20-3N) .Eff. 6 Dec.

SUARNABHUMI Departure 119.25	Apt Elev 5	Trans alt: 11000
------------------------------------	---------------	------------------

1. RNAV1 required. 2. GNSS or DME/DME/IRU required. 3. RADAR required.
 4. For non-RNAV equipped aircraft, pilot shall inform ATC in order to get RADAR guidance.
 5. Pilot should plan for possible climb as depicted on SID, actual climb clearance will be given by ATC.
 6. If unable to comply with flight restrictions, advise ATC when aircraft commences to pushback or taxi to the holding point for departure.
 7. Initial climb clearance 6000 or as directed by ATC.

**HHN3H [HHN3H]
 SABIS3H [SABIS3H]
 UKERA3H [UKER3H]
 RNAV DEPARTURES
 (RWY 01L)**

**.SPEED: MAX 250 KT AT OR BELOW
 10000 UNLESS OTHERWISE
 AUTHORIZED BY ATC**

These SIDs require a minimum climb gradient of 322 per NM (5.3%) until passing 8000 ft for airspace restrictions only.

Gnd speed-KT	75	100	150	200	250	300
322 per NM	402	537	805	1073	1342	1610

LOST COMMS ▼ LOST COMMS ▼ LOST COMMS ▼ LOST COMMS ▼ LOST COMMS ▼ LOST COMMS ▼ LOST COMMS ▼ LOST COMMS ▼ LOST COMMS ▼ LOST COMMS ▼ LOST COMMS ▼ LOST COMMS ▼ LOST COMMS ▼ LOST COMMS ▼ LOST COMMS ▼

1. Set the aircraft transponder to mode A/C code 7600.
2. Comply with the last acknowledged clearance up to the next reporting point in the SID, then climb to the flight planned cruising level in accordance with the published all speed and altitude restrictions of the relevant SID procedure. Thereafter comply with the flight planned routing and level.
3. When a departing aircraft is being RADAR vectored, if no transmissions are heard on the frequency in use for a period of two minutes, a radio frequency check is to be made. If the radio frequency check indicates a radio communication failure, the pilot shall MAINTAIN the last assigned heading, speed and level, or minimum flight altitude if higher. After a period of two minutes, the flight shall rejoin in the most direct manner possible to rejoin the SID procedure appropriate to its ATIS route or the flight plan route no later than the next significant point. Thereafter comply with the flight planned routing and level.

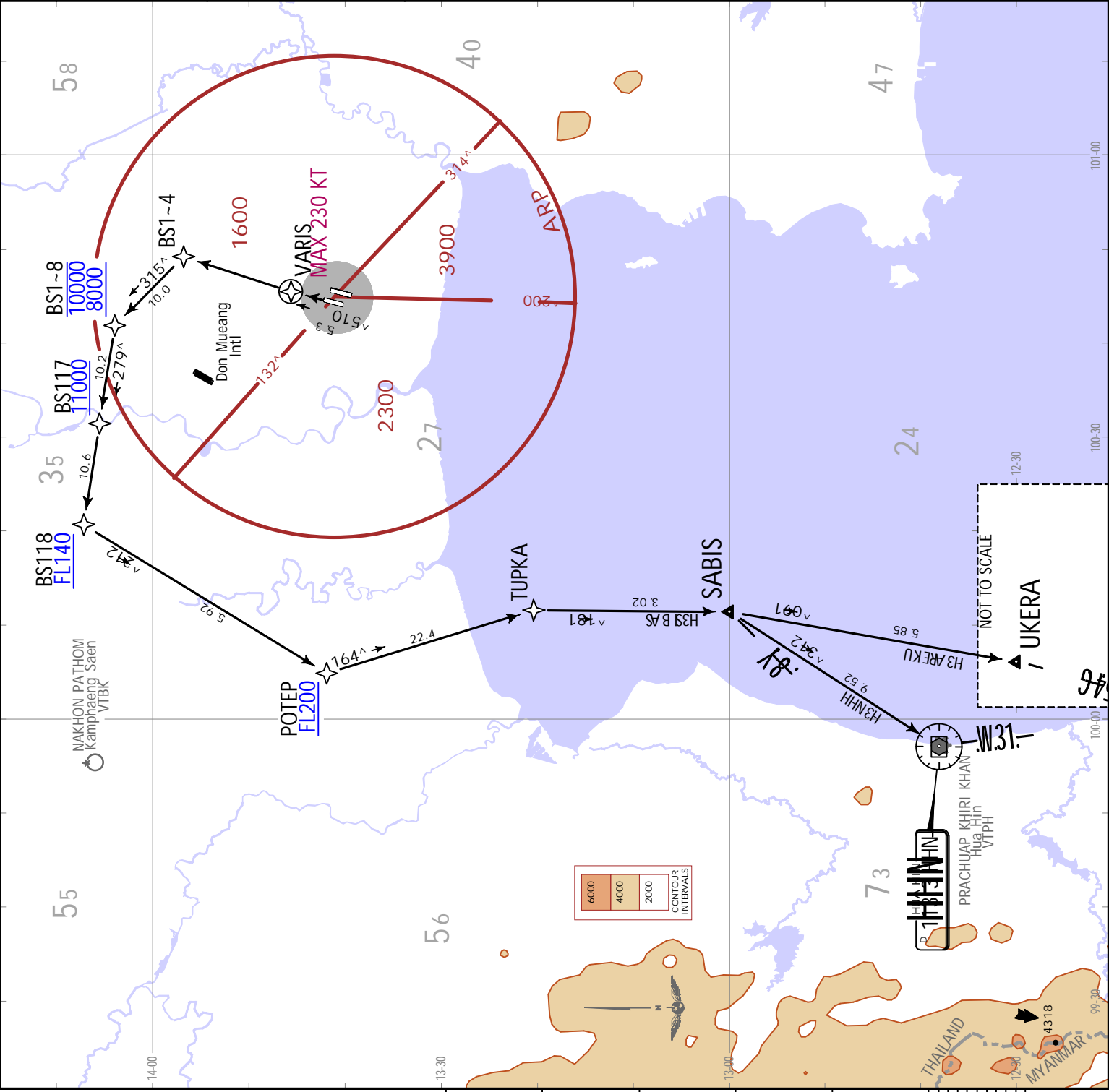

SUVARNABHUMI
 Departure
119.25

Apt Elev
5

Trans alt: 11000

1. RNAV1 required. 2. GNSS or DME/DME/IRU required. 3. RADAR required.
 4. For non-RNAV equipped aircraft, pilot shall inform ATC in order to get RADAR guidance.
 5. Pilot should plan for possible climb as depicted on SID, actual climb clearance will be given by ATC.
 6. If unable to comply with flight restrictions, advise ATC when aircraft commences to pushback or taxi to the holding point for departure.
 7. Initial climb clearance 6000 or as directed by ATC.

HHN3K [HHN3K]
SABIS3K [SABIS3K]
UKERA3K [UKERA3K]
RNAV DEPARTURES
(RWY 01R)

.SPEED: MAX 250 KT AT OR BELOW
10000 UNLESS OTHERWISE
AUTHORIZED BY ATC

These SIDs require a minimum climb gradient of 322 per NM (5.3%) until passing 8000 for airspace restrictions only.

Gnd speed-KT	75	100	150	200	250	300
322 per NM	402	537	805	1073	1342	1610

LOST COMMS ▼ LOST COMMS ▼ LOST COMMS ▼ LOST COMMS ▼ LOST COMMS

1. Set the aircraft transponder to mode A/C code 7600.

2. Comply with the last acknowledged clearance up to the next reporting point in the SID, then climb to the flight planned cruising level in accordance with the published all speed and altitude restrictions of the relevant SID procedure. Thereafter comply with the flight planned routing and level.

3. When a departing aircraft is being RADAR vectored, if no transmissions are heard on the frequency in use for a period of two minutes, a radio frequency check is to be made. If the radio frequency check indicates a radio communication failure, the pilot shall MAINTAIN the last assigned heading, speed and level, or minimum flight altitude if higher. After a period of two minutes, the flight shall rejoin in the most direct manner possible to rejoin the SID procedure appropriate to its ATS route or the flight plan route no later than the next significant point. Thereafter comply with the flight planned routing and level.

LOST COMMS ▲ LOST COMMS ▲ LOST COMMS ▲ LOST COMMS ▲ LOST COMMS

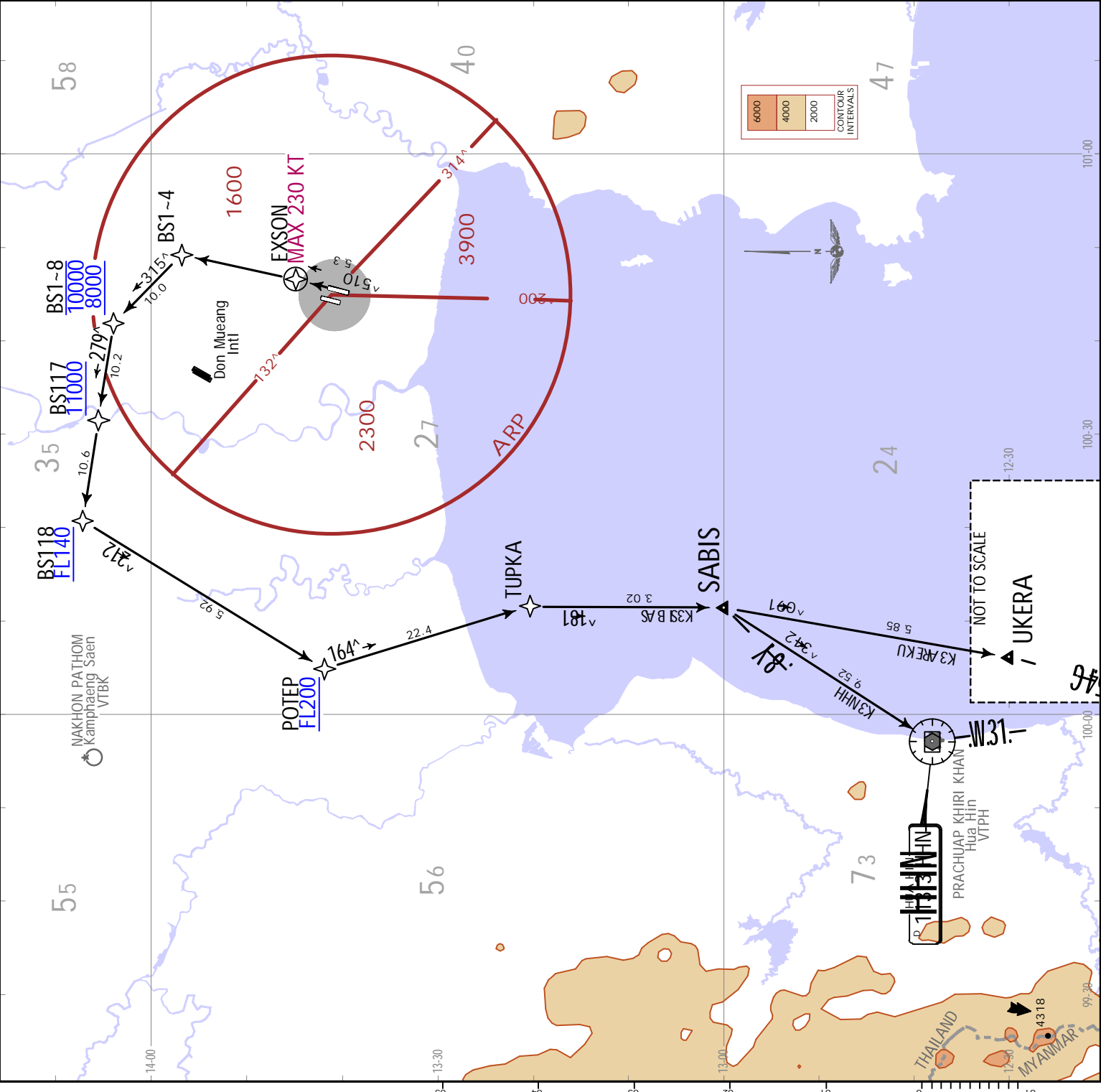

VTBS/BKK

+JEPPESEN

TAXI.
BANGKOK, THAILAND
SUVARNABHUMI INTL

12 JAN 07

20-6

STANDARD TAXI ROUTES FOR ARRIVALS AND DEPARTURES

For arriving aircraft, the standard taxi routes to aircraft parking stand are provided in relation to landing runway followed by series of relevant taxiways, and parking area.

The following phrase will be transmitted:

'... C/S... TAXI VIA ROUTE ONE NINE RIGHT, ECHO TANGO THREE TO STAND ONE ZERO THREE.'

When issuing taxi instructions to departing aircraft, Ground controller shall provide a standard taxi route which is in accordance with the relevant parking area, the taxi-out position of an aircraft and runway-in-use.

The following phrase will be transmitted:

'... C/S... TAXI VIA ROUTE MIKE TANGO ONE ZERO, RUNWAY ONE NINE LEFT.'

ARRIVALS RUNWAY 19R

Apron	Taxi Route Designator	Taxi Route Detail	Aircraft Stands
Main Apron	19R / MT9	Exit onto E, D7, G, T9 then turn right T12, T8	C2, C4, C6, C8, C10
		Exit onto E, D7, G, T9	301-304
		Exit onto E, D7, G, T9 then turn right T12	D1, D2
		Exit onto E, D7, G, T9 then turn left T12	D3, D4
	19R / MT10	Exit onto E, D7, G, T10 then turn right T12	D5, D6
		Exit onto E, D7, G, T10 then turn left T12	D7, D8
		Exit onto E, D7, G, T10 then turn left T12, T11	E1, E3, E5, E7, E9
		Exit onto E, D7, G, T10	305-308
East Apron	19R / ET3	Exit onto E, D7, G then turn left C, T3 then turn left T5	A1-A6, 101, 115-118
		Exit onto E, D7, G then turn left C, T3 then turn right T5	102-114, 119-129
		Exit onto E, D7, G then turn left C, T3 then turn left T5, T4	B1, B3, B5
		Exit onto E, D7, G then turn left C, T3 then turn right T5, T1	130-134
	19R / ET6	Exit onto E, D7, G then turn left C T6	B2, B4, B6
		Exit onto E, D7, G then turn left C T6, T7	C1, C3, C5, C7, C9, 201-203
West Apron	19R / WD1	Exit onto E, D1 then turn right D	510-518
		Exit onto E, D1 then turn left D	519-525
	19R / WD3	Exit onto E, D3 then turn right D	506-509
	19R / WT14	Exit onto E, D6, T14, T13	E2, E4, E6, E8, E10, 401-403
		Exit onto E, D6, T14	F1, F3, F5
	19R / WT15	Exit onto E, D5, T15	F2, F4, F6
Exit onto E, D5, T15, T17		G1-G5, 501-505	

VTBS/BKK

+JEPPESEN

TAXI.
BANGKOK, THAILAND
SUVARNABHUMI INTL

12 JAN 07

20-6A

ARRIVALS RUNWAY 19L			
Apron	Taxi Route Designator	Taxi Route Detail	Aircraft Stands
Main Apron	19L / MT9	Exit onto B, C7, H, H3, T9 then turn right T12, T8	C2, C4, C6, C8, C10
		Exit onto B, C7, H, H3, T9	301-304
		Exit onto B, C7, H, H3, T9 then turn right T12	D1, D2
		Exit onto B, C7, H, H3, T9 then turn left T12	D3, D4
	19L / MT10	Exit onto B, C7, H, H2, T10 then turn right T12	D5, D6
		Exit onto B, C7, H, H2, T10 then turn left T12	D7, D8
		Exit onto B, C7, H, H2, T10 then turn left T12, T11	E1, E3, E5, E7, E9
	Exit onto B, C7, H, H2, T10	305-308	
East Apron	19L / ET3	Exit onto B, C7 then turn right C, T3 then turn left T5	A1-A6, 101, 115-118
		Exit onto B, C7 then turn right C, T3 then turn right T5	102-114, 119-129
		Exit onto B, C7 then turn right C, T3 then turn left T5, T4	B1, B3, B5
		Exit onto B, C7 then turn right C, T3 then turn right T5, T1	130-134
	19L / ET6	Exit onto B, C7 then turn right C, T6	B2, B4, B6
		Exit onto B, C7 then turn right C, T6, T7	C1, C3, C5, C7, C9, 201-203
West Apron	19L / WD1	Exit onto B, C7, H, D8 then turn right E, D1 then turn right D	510-518
		Exit onto B, C7, H, D8 then turn right E, D1 then turn left D	519-525
	19L / WD3	Exit onto B, C7, H, D8 then turn right E, D3 then turn right D	506-509
	19L / WT14	Exit onto B, C7, H, D8 then turn right E, D6, T14, T13	E2, E4, E6, E8, E10, 401-403
		Exit onto B, C7, H, D8 then turn right E, D6, T14	F1, F3, F5
	19L / WT15	Exit onto B, C7, H, D8 then turn right E, D5, T15	F2, F4, F6
		Exit onto B, C7, H, D8 then turn right E, D5, T15, T17	G1-G5, 501-505

VTBS/BKK

+JEPPESEN

TAXI.
BANGKOK, THAILAND
SUVARNABHUMI INTL

12 JAN 07

20-6B

DEPARTURES RUNWAY 19R			
Apron	Taxi Route Designator	Taxi Route Detail	Aircraft Stands
Main Apron	MT8 / 19R	T12, T8, H3 then turn right H, D8 then turn right E to holding position E1	D1-D4
		T9 then turn right T12, T8, H3 then turn right H, D8 then turn right E to holding position E1	301-304
		T8, H3 then turn right H, D8 then turn right E to holding position E1	C2, C4, C6, C8, C10
	MT11 / 19R	T12, T11, H2 then turn right H, D8 then turn right E to holding position E1	D5-D8
		T11, H2 then turn right H, D8 then turn right E to holding position E1	E1, E3, E5, E7, E9
		T10 then turn left T12, T11, H2 then turn right H, D8 then turn right E to holding position E1	305-308
East Apron	ET1 / 19R	T5, T1, C, C2, B, C7, H, D8 then turn right E to holding position E1	109-114, 124-129
		T1, C, C2, B, C7, H, D8 then turn right E to holding position E1	130-134
	ET2 / 19R	T5, T2, then turn right C, C2, B, C7, H, D8 then turn right E to holding position E1	102-108, 119-123
	ET4 / 19R	T5, T4, C4 then turn right B, C7, H, D8 then turn right E to holding position E1	A1-A6, 101, 115-118
		T4, C4 then turn right B, C7, H, D8 then turn right E to holding position E1	B1, B3, B5
	ET7 / 19R	T6, T7, H4 then turn right H, D8 then turn right E to holding position E1	B2, B4, B6
		T7, H4 then turn right H, D8 then turn right E to holding position E1	C1, C3, C5, C7, C9, 201-203
West Apron	WD2 / 19R	D, D2 to holding position E1	511-525
	WD4 / 19R	D, D4 then turn right E to holding position E1	506-510
	WT13 / 19R	T13, H1 then turn right H, D8 then turn right E to holding position E1	E2, E4, E6, E8, E10, 401-403
		T14, T13, H1 then turn right H, D8 then turn right E to holding position E1	F1, F3, F5
	WT16 / 19R	T15, T17, T16, D4 then turn right E to holding position E1	F2, F4, F6
		T17, T16, D4 then turn right E to holding position E1	G1-G5, 501-505

VTBS/BKK

+JEPPESEN

TAXI.
BANGKOK, THAILAND
SUVARNABHUMI INTL

12 JAN 07

20-6C

DEPARTURES RUNWAY 19L			
Apron	Taxi Route Designator	Taxi Route Detail	Aircraft Stands
Main Apron	MT8 / 19L	T8 then turn left G then turn left C, C2, B to holding position B1	C2, C4, C6, C8, C10
		T9 then turn right T12, T8 then turn left G then turn left C, C2, B to holding position B1	301-304
		T12, T8 then turn left G then turn left C, C2, B to holding position B1	D1-D4
	MT11 / 19L	T12, T11 then turn left G then turn left C, C2, B to holding position B1	D5-D8
		T11 then turn left G then turn left C, C2, B to holding position B1	E1, E3, E5, E7, E9
		T10 then turn left T12, T11 then turn left G then turn left C, C2, B to holding position B1	305-308
East Apron	ET1 / 19L	T5 then turn right T1, C, C2, B to holding position B1	109-114, 124-129
		T1, C, C2, B to holding position B1	130-133
	ET2 / 19L	T5, T2 then turn right C, C2, B to holding position B1	102-108, 119-123
	ET4 / 19L	T5, T4 then turn left C, C2, B to holding position B1	A1-A6, 101, 115-118
		T4 then turn left C, C2, B to holding position B1	B1, B3, B5
	ET7 / 19L	T6, T7 then turn left G then turn left C, C2, B to holding position B1	B2, B4, B6
T7 then turn left G then turn left C, C2, B to holding position B1		C1, C3, C5, C7, C9, 201-203	
West Apron	WD / 19L	Straight ahead on D, G then turn left C, C2, B to holding position B1	506-525
	WT13 / 19L	T13 then turn left G then turn left C, C2, B to holding position B1	E2, E4, E6, E8, E10, 401-403
		T14, T13 then turn left G then turn left C, C2, B to holding position B1	F1, F3, F5
	WT16 / 19L	T15, T17, T16 then turn left D, G then turn left C, C2, B to holding position B1	F2, F4, F6
		T17, T16 then turn left D, G then turn left C, C2, B to holding position B1	G1-G5, 501-505

VTBS/BKK

+JEPPESEN

TAXI.
BANGKOK, THAILAND
SUVARNABHUMI INTL

12 JAN 07

20-6D

ARRIVALS RUNWAY 01L			
Apron	Taxi Route Designator	Taxi Route Detail	Aircraft Stands
Main Apron	01L / MT9	Exit on E12 then turn left E, D7, G, T9 then turn right T12, T8	C2, C4, C6, C8, C10
		Exit on E7, E8, D6 then turn right D, G, T9 then turn right T12, T8	
		Exit on E5 then turn left E, D3 then turn right D, G, T9 then turn right T12, T8	
		Exit on E2, D3 then turn right D, G, T9 then turn right T12, T8	
		Exit on E12 then turn left E, D7, G, T9	301-304
		Exit on E7, E8, D6 then turn right D, G, T9	
		Exit on E5 then turn left E, D3 then turn right D, G, T9	
		Exit on E2, D3 then turn right D, G, T9	D1, D2
		Exit on E12 then turn left E, D7, G, T9 then turn right T12	
		Exit on E7, E8, D6 then turn right D, G, T9 then turn right T12	
		Exit on E5 then turn left E, D3 then turn right D, G, T9 then turn right T12	
		Exit on E12 then turn left E, D7, G, T9 then turn left T12	D3, D4
		Exit on E7, E8, D6 then turn right D, G, T9 then turn left T12	
		Exit on E5 then turn left E, D3 then turn right D, G, T9 then turn left T12	
		Exit on E2, D3 then turn right D, G, T9 then turn left T12	

VTBS/BKK

+JEPPESEN

TAXI.
BANGKOK, THAILAND
SUVARNABHUMI INTL

12 JAN 07

20-6E

ARRIVALS RUNWAY 01L			
Apron	Taxi Route Designator	Taxi Route Detail	Aircraft Stands
Main Apron	01L / MT10	Exit on E12 then turn left E, D7, G, T10 then turn right T12	D5, D6
		Exit on E7, E8, D6 then turn right D, G, T10 then turn right T12	
		Exit on E5 then turn left E, D3 then turn right D, G, T10 then turn right T12	
		Exit on E2, D3 then turn right D, G, T10 then turn right T12	
		Exit on E12 then turn left E, D7, G, T10 then turn left T12	D7, D8
		Exit on E7, E8, D6 then turn right D, G, T10 then turn left T12	
		Exit on E5 then turn left E, D3 then turn right D, G, T10 then turn left T12	
		Exit on E2, D3 then turn right D, G, T10 then turn left T12	E1, E3, E5, E7, E9
		Exit on E12 then turn left E, D7, G, T10 then turn left T12, T11	
		Exit on E7, E8, D6 then turn right D, G, T10 then turn left T12, T11	
		Exit on E5 then turn left E, D3 then turn right D, G, T10 then turn left T12, T11	
		Exit on E2, D3 then turn right D, G, T10 then turn left T12, T11	305-308
		Exit on E12 then turn left E, D7, G, T10	
		Exit on E7, E8, D6 then turn right D, G, T10	
		Exit on E5 then turn left E, D3 then turn right D, G, T10	
		Exit on E2, D3 then turn right D, G, T10	

VTBS/BKK

+JEPPESEN

TAXI.
BANGKOK, THAILAND
SUVARNABHUMI INTL

12 JAN 07

20-6F

ARRIVALS RUNWAY 01L			
Apron	Taxi Route Designator	Taxi Route Detail	Aircraft Stands
East Apron	01L / ET3	Exit on E12 then turn left E, D7, G then turn left C, T3 then turn left T5	A1-A6, 101, 115-118
		Exit on E7, E8, D6 then turn right D, G then turn left C, T3 then turn left T5	
		Exit on E5 then turn left E, D3 then turn right D, G then turn left C, T3 then turn left T5	
		Exit on E2, D3 then turn right D, G then turn left C, T3 then turn left T5	
		Exit on E12 then turn left E, D7, G then turn left C, T3 then turn right T5	102-114, 119-129
		Exit on E7, E8, D6 then turn right D, G then turn left C, T3 then turn right T5	
		Exit on E5 then turn left E, D3 then turn right D, G then turn left C, T3 then turn right T5	
		Exit on E2, D3 then turn right D, G then turn left C, T3 then turn right T5	
		Exit on E12 then turn left E, D7, G then turn left C, T3 then turn left T5, T4	B1, B3, B5
		Exit on E7, E8, D6 then turn right D, G then turn left C, T3 then turn left T5, T4	
		Exit on E5 then turn left E, D3 then turn right D, G then turn left C, T3 then turn left T5, T4	
		Exit on E2, D3 then turn right D, G then turn left C, T3 then turn left T5, T4	
	Exit on E12 then turn left E, D7, G then turn left C, T3 then turn right T5, T1	130-134	
	Exit on E7, E8, D6 then turn right D, G then turn left C, T3 then turn right T5, T1		
	Exit on E5 then turn left E, D3 then turn right D, G then turn left C, T3 then turn right T5, T1		
	Exit on E2, D3 then turn right D, G then turn left C, T3 then turn right T5, T1		
	01L / ET6	Exit on E12 then turn left E, D7, G then turn left C, T6	B2, B4, B6
		Exit on E7, E8, D6 then turn right D, G then turn left C, T6	
		Exit on E5 then turn left E, D3 then turn right D, G then turn left C, T6	
		Exit on E2, D3 then turn right D, G then turn left C, T6	
Exit on E12 then turn left E, D7, G then turn left C, T6, T7		C1, C3, C5, C7, C9, 201-203	
Exit on E7, E8, D6 then turn right D, G then turn left C, T6, T7			
Exit on E5 then turn left E, D3 then turn right D, G then turn left C, T6, T7			
Exit on E2, D3 then turn right D, G then turn left C, T6, T7			

VTBS/BKK

+JEPPESEN

TAXI.
BANGKOK, THAILAND
SUARNABHUMI INTL

12 JAN 07

20-6G

ARRIVALS RUNWAY 01L			
Apron	Taxi Route Designator	Taxi Route Detail	Aircraft Stands
West Apron	01L / WD1	Exit on E12 then turn left E, D1 then turn right D	510-518
		Exit on E7 then turn left E, D1 then turn right D	
		Exit on E5 then turn left E, D1 then turn right D	
		Exit on E2 then turn left E, D1 then turn right D	
		Exit on E12 then turn left E, D1 then turn left D	519-525
		Exit on E7 then turn left E, D1 then turn left D	
		Exit on E5 then turn left E, D1 then turn left D	
		Exit on E2 then turn left E, D1 then turn left D	
	01L / WD3	Exit on E12 then turn left E, D3 then turn right D	506-509
		Exit on E7 then turn left E, D3 then turn right D	
		Exit on E5 then turn left E, D3 then turn right D	
		Exit on E2, D3 then turn right D	
	01L / WT14	Exit on E12 then turn left E, D6, T14, T13	E2, E4, E6, E8, E10, 401-403
		Exit on E7, E8, D6, T14, T13	
		Exit on E5 then turn left E, D3 then turn right D, T14, T13	
		Exit on E2, D3 then turn right D, T14, T13	
		Exit on E12 then turn left E, D6, T14	F1, F3, F5
		Exit on E7, E8, D6, T14	
		Exit on E5 then turn left E, D3 then turn right D, T14	
		Exit on E2, D3 then turn right D, T14	
01L / WT15	Exit on E12 then turn left E, D5, T15	F2, F4, F6	
	Exit on E7 then turn left E, D5, T15		
	Exit on E5 then turn left E, D3 then turn right D, T15		
	Exit on E2, D3 then turn right D, T15		
	Exit on E12 then turn left E, D5, T15, T17	G1-G5, 501-505	
	Exit on E7 then turn left E, D5, T15, T17		
	Exit on E5 then turn left E, D3 then turn right D, T15, T17		
	Exit on E2, D3 then turn right D, T15, T17		

VTBS/BKK

+JEPPESEN

TAXI.
BANGKOK, THAILAND
SUVARNABHUMI INTL

12 JAN 07

20-6H

ARRIVALS RUNWAY 01R			
Apron	Taxi Route Designator	Taxi Route Detail	Aircraft Stands
Main Apron	01R / MT9	Exit on B7, B9, C10, C, H, H3, T9 then turn right T12, T8	C2, C4, C6, C8, C10
		Exit on B5, B6, C8 then turn right C, H, H3, T9 then turn right T12, T8	
		Exit on B3, B4 then turn left B, C7, H, H3, T9 then turn right T12, T8	
		Exit on B2 then turn left B, C7, H, H3, T9 then turn right T12, T8	
		Exit on B8, B9, C10, C, H, H3, T9	301-304
		Exit on B5, B6, C8 then turn right C, H, H3, T9	
		Exit on B3, B4 then turn left B, C7, H, H3, T9	
		Exit on B2 then turn left B, C7, H, H3, T9	
		Exit on B7, B9, C10, C, H, H3, T9 then turn right T12	D1, D2
		Exit on B5, B6, C8 then turn right C, H, H3, T9 then turn right T12	
		Exit on B3, B4 then turn left B, C7, H, H3, T9 then turn right T12	
		Exit on B2 then turn left B, C7, H, H3, T9 then turn right T12	
		Exit on B8, B9, C10, C, H, H3, T9 then turn left T12	D3, D4
		Exit on B5, B6, C8 then turn right C, H, H3, T9 then turn left T12	
		Exit on B3, B4 then turn left B, C7, H, H3, T9 then turn left T12	
		Exit on B2 then turn left B, C7, H, H3, T9 then turn left T12	

VTBS/BKK

+JEPPESEN

TAXI.
BANGKOK, THAILAND
SUVARNABHUMI INTL

12 JAN 07

20-6J

ARRIVALS RUNWAY 01R			
Apron	Taxi Route Designator	Taxi Route Detail	Aircraft Stands
Main Apron	01R / MT10	Exit on B7, B9, C10, C, H, H2, T10 then turn right T12	D5, D6
		Exit on B5, B6, C8 then turn right C, H, H2, T10 then turn right T12	
		Exit on B3, B4 then turn left B, C7, H, H2, T10 then turn right T12	
		Exit on B2 then turn left B, C7, H, H2, T10 then turn right T12	
		Exit on B7, B9, C10, C, H, H2, T10 then turn left T12	D7, D8
		Exit on B5, B6, C8 then turn right C, H, H2, T10 then turn left T12	
		Exit on B3, B4 then turn left B, C7, H, H2, T10 then turn left T12	
		Exit on B2 then turn left B, C7, H, H2, T10 then turn left T12	E1, E3, E5, E7, E9
		Exit on B7, B9, C10, C, H, H2, T10 then turn left T12, T11	
		Exit on B5, B6, C8 then turn right C, H, H2, T10 then turn left T12, T11	
		Exit on B3, B4 then turn left B, C7, H, H2, T10 then turn left T12, T11	
		Exit on B2 then turn left B, C7, H, H2, T10 then turn left T12, T11	305-308
		Exit on B7, B9, C10, C, H, H2, T10	
		Exit on B5, B6, C8 then turn right C, H, H2, T10	
		Exit on B3, B4 then turn left B, C7, H, H2, T10	

VTBS/BKK

 **JEPPesen**

BANGKOK, THAILAND

9 AUG 19 (20-6K) .Eff.15.Aug.

SUVARNABHUMI INTL

ARRIVALS RUNWAY 01R			
Apron	Taxi Route Designator	Taxi Route Detail	Aircraft Stands
East Apron	01R/ET3	Exit on B7, B9, C10, C, T3 then turn left T5	A1-A6, 101, 115-118
		Exit on B5, B6, C8 then turn right C, T3 then turn left T5	
		Exit on B3, B4 then turn left B, C7 then turn right C, T3 then turn left T5	
		Exit on B2 then turn left B, C5 then turn right C, T3 then left T5	
		Exit on B7, B9, C10, C, T3 then turn right T5	102-114, 119-129
		Exit on B5, B6, C8 then turn right C, T3 then turn right T5	
		Exit on B3, B4 then turn left B, C7 then turn right C, T3 then turn right T5	
		Exit on B2 then turn left B, C5 then turn right C, T3 then turn right T5	
	Exit on B7, B9, C10, C, T3 then turn left T5, T4	B1, B3, B5	
	Exit on B5, B6, C8 then turn right C, T3 then turn left T5, T4		
	Exit on B3, B4 then turn left B, C7 then turn right C, T3 then turn right T5, T4		
	Exit on B2 then turn left B, C5 then turn right C, T3 then left T5, T4		
	Exit on B7, B9, C10, C, T3 then turn right T5, T1	130-134	
	Exit on B5, B6, C8, then turn right C, T3 then turn right T5, T1		
	Exit on B3, B4 then turn left B, C7 then turn right C, T3 then turn right T5, T1		
	Exit on B2 then turn left B, C5 then turn right C, T3 then right T5, T1		
	01R/ET6	Exit on B7, B9, C10, C, T6	B2, B4, B6
		Exit on B5, B6, C8 then turn right C, T6	
		Exit on B3, B4 then turn left B, C7 then turn right C, T6	
		Exit on B2 then turn left B, C5, T6	
Exit on B7, B9, C10, C, T6, T7		C1, C3, C5, C7 C9, 201-203	
Exit on B5, B6, C8 then turn right C, T6, T7			
Exit on B3, B4 then turn left B, C7 then turn right C, T6, T7			
Exit on B2 then turn left B, C5, T6, T7			

VTBS/BKK



BANGKOK, THAILAND

9 AUG 19 (20-6L) .Eff.15.Aug.

SUVARNABHUMI INTL

ARRIVALS RUNWAY 01R				
Apron	Taxi Route Designator	Taxi Route Detail	Aircraft Stands	
West Apron	01R/WD1	Exit on B7, B9, C10, C, H, D8 then turn right E, D1 then turn right D	510-518	
		Exit on B5, B6, C8 then turn right C, H, D8 then right E, D1 then turn right D		
		Exit on B3, B4 then left B, C7, H, D8 then turn right E, D1 then turn right D		
		Exit on B2 then turn left B, C7, H, D8 then turn right E, D1 then turn right D		
		Exit on B7, B9, C10, C, H, D8 then turn right E, D1 then turn left D		519-525
		Exit on B5, B6, C8 then turn right C, H, D8 then turn right E, D1 then turn left D		
		Exit on B3, B4 then turn left B, C7, H, D8 then turn right E, D1 then turn left D		
		Exit on B2 then left B, C7, H, D8 then turn right E, D1 then turn left D		
	01R/WD3	Exit on B7, B9, C10, C, H, D8 then turn right E, D3 then turn right D	506-509	
		Exit on B5, B6, C8 then turn right C, H, D8 then turn right E, D3 then turn right D		
		Exit on B3, B4 then turn left B, C7, H, D8 then turn right E, D3 then turn right D		
		Exit on B2 then turn left B, C7, H, D8 then turn right E, D3 then turn right D		
	01R/WT14	Exit on B7, B9, C10, C, H, D8 then turn right E, D6, T14, T13	E2, E4, E6, E8, E10, 401-403	
		Exit on B5, B6, C8 then turn right C, H, D8 then turn right E, D6, T14, T13		
		Exit on B3, B4 then left B, C7, H, D8 then turn right E, D6, T14, T13		
		Exit on B2 then turn left B, C7, H, D8 then turn right E, D6, T14, T13		
Exit on B7, B9, C10, C, H, D8 then turn right E, D6, T14,		F1, F3, F5		
Exit on B5, B6, C8 then turn right C, H, D8 then turn right E, D6, T14				
Exit on B3, B4 then turn left B, C7, H, D8 then turn right E, D6, T14				
Exit on B2 then turn left B, C7, H, D8 then turn right E, D6, T14				

VTBS/BKK



BANGKOK, THAILAND

9 AUG 19 (20-6M) .Eff.15.Aug.

SUVARNABHUMI INTL

ARRIVALS RUNWAY 01R			
Apron	Taxi Route Designator	Taxi Route Detail	Aircraft Stands
West Apron	01R/WT15	Exit on B7, B9, C10, C, H, D8 then turn right E, D5, T15	F2, F4, F6
		Exit on B5, B6, C8 then turn right C, H, D8 then turn right E, D5, T15	
		Exit on B3, B4 then turn left B, C7, H, D8 then turn right E, D5, T15	
		Exit on B2 then turn left B, C7, H, D8 then turn right E, D5, T15	
		Exit on B7, B9, C10, C, H, D8 then turn right E, D5, T15, T17	G1-G5, 501-505
		Exit on B5, B6, C8 then turn right C, H, D8 then turn right E, D5, T15, T17	
		Exit on B3, B4 then turn left B, C7, H, D8 then turn right E, D5, T15, T17	
		Exit on B2 then turn left B, C7, H, D8 then turn right E, D5, T15, T17	
DEPARTURES RUNWAY 01L			
Apron	Taxi Route Designator	Taxi Route Detail	Aircraft Stands
Main Apron	MT8/01L	T8, H3 then turn right H then turn left D, D9 then turn left E to holding position E21	C2, C4, C6, C8, C10
		T9 then turn right T12, T8, H3 then turn right H then turn left D, D9 then turn left E to holding position E21	301-304
		T12, T8, H3 then turn right H then turn left D, D9 then turn left E to holding position E21	D1-D4
	MT11/01L	T12, T11, H2 then turn right H then turn left D, D9 then turn left E to holding position E21	D5-D8
		T11, H2 then turn right H then turn left D, D9 then turn left E to holding position E21	E1, E3, E5, E7, E9
		T10 then turn left T12, T11, H2 then turn right H then turn left D, D9 then turn left E to holding position E21	305-308
East Apron	ET1/01L	T5, T1 then turn right C, C2, B, C7, H then turn left D, D9 then turn left E to holding position E21	109-114, 124-129
		T1, C, C2, B, C7, H then turn left D, D9 then turn left E to holding position E21	130-134
	ET2/01L	T5, T2 then turn right C, C2, B, C7, H then turn left D, D9 then turn left E to holding position E21	102-108, 119-123
	ET4/01L	T5, T4, C4 then turn right B, C7, H then turn left D, D9 then turn left E to holding position E21	A1-A6, 101, 115-118
		T4, C4 then turn right B, C7, H then turn left D, D9 then turn left E to holding position E21	B1, B3, B5
	ET7/01L	T6, T7, H4 then turn right H then turn left D, D9 then turn left E to holding position E21	B2, B4, B6
T7, H4 then turn right H then turn left D, D9 then turn left E to holding position E21		C1, C3, C5, C7, C9, 201-203	

VTBS/BKK

 **JEPPESSEN**
9 AUG 19 (20-6N) .Eff.15.Aug.

BANGKOK, THAILAND

SUVARNABHUMI INTL

DEPARTURES RUNWAY 01L			
Apron	Taxi Route Designator	Taxi Route Detail	Aircraft Stands
West Apron	WD/01L	Straight ahead on D, D9 then turn left E to holding position E21	506-525
	WT13/01L	T13, H1 then turn right H then left D, D9 then turn left E to holding position E21	E2, E4, E6, E8 E10, 401-403
		T14, T13, H1 then turn right H then left D, D9 then turn left E to holding position E21	F1, F3, F5
	WT16/01L	T15, T17, T16 then turn left D, D9 then turn left E to holding position E21	F2, F4, F6
		T17, T16 then left D, D9 then turn left E to holding position E21	G1-G5, 501-505
DEPARTURES RUNWAY 01R			
Apron	Taxi Route Designator	Taxi Route Detail	Aircraft Stands
Main Apron	MT8/01R	T8 then turn left G, C6 then turn right B to holding position B13	C2, C4, C6, C8, C10
		T9 then turn right T12, T8 then turn left G, C6 then turn right B to holding position B13	301-304
		T12, T8 then turn left G, C6 then turn right B to holding position B13	D1-D4
	MT11/01R	T12, T11 then turn left G, C6 then turn right B to holding position B13	D5-D8
		T11 then turn left G, C6 then turn right B to holding position B13	E1, E3, E5, E7, E9
		T10 then turn left T12, T11 then turn left G, C6 then turn right B to holding position B13	305-308
East Apron	ET1/01R	T5 then turn right T1, C, C2, B to holding position B13	109-114, 124-129
		T1, C, C2, B to holding position B13	130-134
	ET2/01R	T5, T2 then turn right C, C2, B to holding position B13	102-108, 119-123
	ET4/01R	T5, T4, C4 then turn right B to holding position B13	A1-A6, 101, 115-118
		T4, C4 then turn right B to holding position B13	B1, B3, B5
	ET7/01R	T6, T7 then turn left G, C6 then turn right B to holding position B13	B2, B4, B6
T7 then turn left G, C6 then turn right B to holding position B13		C1, C3, C5 C7, C9, 201-203	
West Apron	WD/01R	Straight ahead on D then turn left G, C6 then turn right B to holding position B13	506-525
	WT13/01R	T13 then turn left G, C6 then turn right B to holding position B13	E2, E4, E6, E8, E10, 401-403
		T14, T13 then turn left G, C6 then turn right B to holding position B13	F1, F3, F5
	WT16/01R	T15, T17, T16 then turn left D then turn left G, C6 then turn right B to holding position B13	F2, F4, F6
		T17, T16 then turn left D then turn left G, C6 then turn right B to holding position B13	G1-G5, 501-505

**THE UTILIZATION AND CONDITIONS OF THE SAT-1 TAXIWAY
AND NORTH APRON AREAS
AT SUVARNABHUMI INTERNATIONAL AIRPORT
(SUP A08/23 AIRAC)**

1. INTRODUCTION

With effect from 23 March 2023 at 0100 UTC to 30 September 2023 at 0100 UTC, the purpose of these charts is to inform all parties concerned of the establishment of Taxiway H5, Taxiway H6, Taxiway J, Taxiway J1, Taxiway J2, Taxiway J3, Taxiway J4, Taxiway K, Taxilane T18, Taxilane T19 and 14 aircraft parking stands (North Apron) at new Midfield Satellite building 1 (SAT-1) for aircraft parking.

2. UTILIZATION AND CONDITIONS

- 2.1. The Air Traffic Service (ATS) is not provided at the SAT-1 area.
- 2.2. The use of Taxiway H5, Taxiway H6, Taxiway J, Taxiway J1, Taxiway J2, Taxiway J3, Taxiway J4, Taxiway K, Taxilane T18, Taxilane T19 and aircraft parking stands must be authorized by AOT.
- 2.3. The aircraft which will be parked at the SAT-1 area must be authorized by AOT.
- 2.4. Upon operating to and from the SAT-1 area, the authorized aircraft shall be towed and required to strictly follow the 'Follow Me' guidance.
- 2.5. The start and/or operation of aircraft engines at the SAT-1 area is not allowed except running at minimum idle power to maintain serviceable condition, but with prior permission from AOT before the commencement of such operation.
- 2.6. Any additional/ad hoc conditions that might arise during this period are subject to the discretion of AOT.

3. DETAILS OF THE NEW TAXIWAYS AND TAXILANES AT THE SAT-1 AREA

- 3.1. Taxiway J, Taxiway J1, Taxiway J2, Taxiway J3, Taxiway J4, Taxiway K, Taxilane T18 and Taxilane T19 details are as follows: surface type - concrete, bearing strength - PCN 131/R/D/X/T.
- 3.2. Minimum width of taxiways and taxilanes is 98' (30m).
- 3.3. Taxiways and taxilanes are able to accommodate aircraft of size up to code F.
- 3.4. Taxiway edge lights of taxiway H5, taxiway H6 and taxilane T18 are serviceable only when the towing aircraft operates to and from the SAT-1 area.
- 3.5. There are signage leading to and on taxiway H5 and taxiway H6 but the taxiway closure markings are displayed on entrances of taxiway H5 and taxiway H6 to prevent inadvertent access of aircraft to the SAT-1 area.
- 3.6. The SAT-1 area, excluding taxiway H5 and taxiway H6, will be blocked off by barricades painted in alternate band of red and white, the barricades will be lighted by omnidirectional fixed red lights at night and during limited visibility conditions with taxiway closure markings (yellow crosses) displayed on the entrances of this area.

4. DETAILS OF THE NEW AIRCRAFT PARKING STANDS AT THE SAT-1 AREA (NORTH APRON)

Inertial Navigation System (INS) checkpoints are as follows:

Aircraft parking stand identification	Latitude	Longitude
S101	N13 40.9	E100 45.2
S103, S105	N13 40.9	E100 45.1
S107	N13 40.9	E100 45.0
S109, S111L, S111, S111R	N13 41.0	E100 45.0
S113L, S113, S113R, S115L, S115, S115R	N13 41.0	E100 44.9
S117L, S117, S117R, S119	N13 41.0	E100 44.8
S121, S123, S125	N13 41.0	E100 44.7
S127	N13 41.0	E100 44.6

THE UTILIZATION AND CONDITIONS OF THE SAT-1 TAXIWAY AND NORTH APRON AREAS AT SUVARNABHUMI INTERNATIONAL AIRPORT (CONTD)

5. VALIDITY

This chart will remain current until 30 September 2023 at 0100 UTC. Any changes to these charts will be notified by NOTAM.

New taxiways, taxilanes and aircraft stands at the SAT-1 area for aircraft parking.

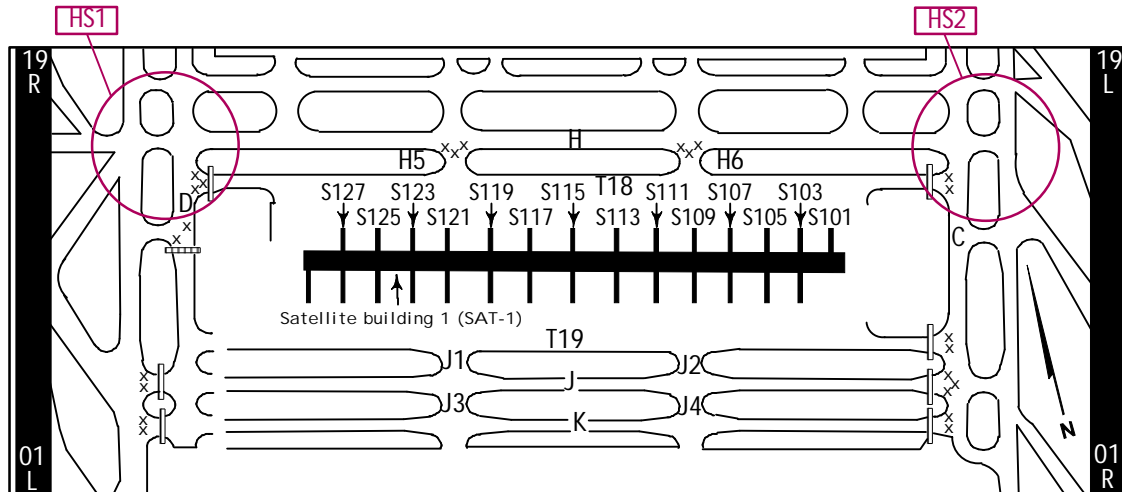

RUNWAY INCURSION HOT SPOTS

HS1

See AIRPORT INFO (CONTD),
TAKE-OFF MNMS for description of Hot Spots

LEGEND

Barricades

Taxiway Closure Markings

THE CLOSURE OF TAXIWAY AT SUVARNABHUMI INTERNATIONAL AIRPORT

1. INTRODUCTION

With effect from 27 AUG 2021 at 0000 UTC, the purpose of this chart is to inform all concerned regarding the closure area for temporary aircraft parking of Taxiway C.

2. CLOSURE AREA

Location	Period (Time in UTC)
Twy C between taxilane T1 and taxilane T2	27 AUG 2021 at 0000 UTC - UFN
Taxiway C1	

3. MARKING AND LIGHTING FOR CLOSURE AREA

- 3.1. The closure area is blocked off by 1' (0.3m) - high frangible barricades painted in alternate bands of red and white and lighted by omnidirectional fixed red lights along the closed area.
- 3.2. The closure markings are displayed on entrances of each closed taxiway (yellow crosses).
- 3.3. Taxiway Center Line Lights and the signage leading to and on the closed area are unserviceable.

4. OPERATING CONDITIONS

The start and/or operation of aircraft engines at the closure is not allowed except running at minimum idle power to maintain serviceable condition, but with prior permission from AOT before the commencement of such operation.

5. VALIDITY

This chart will remain current until further advised. Any changes of this chart will be notified by NOTAM.

Closure area for temporary aircraft parking

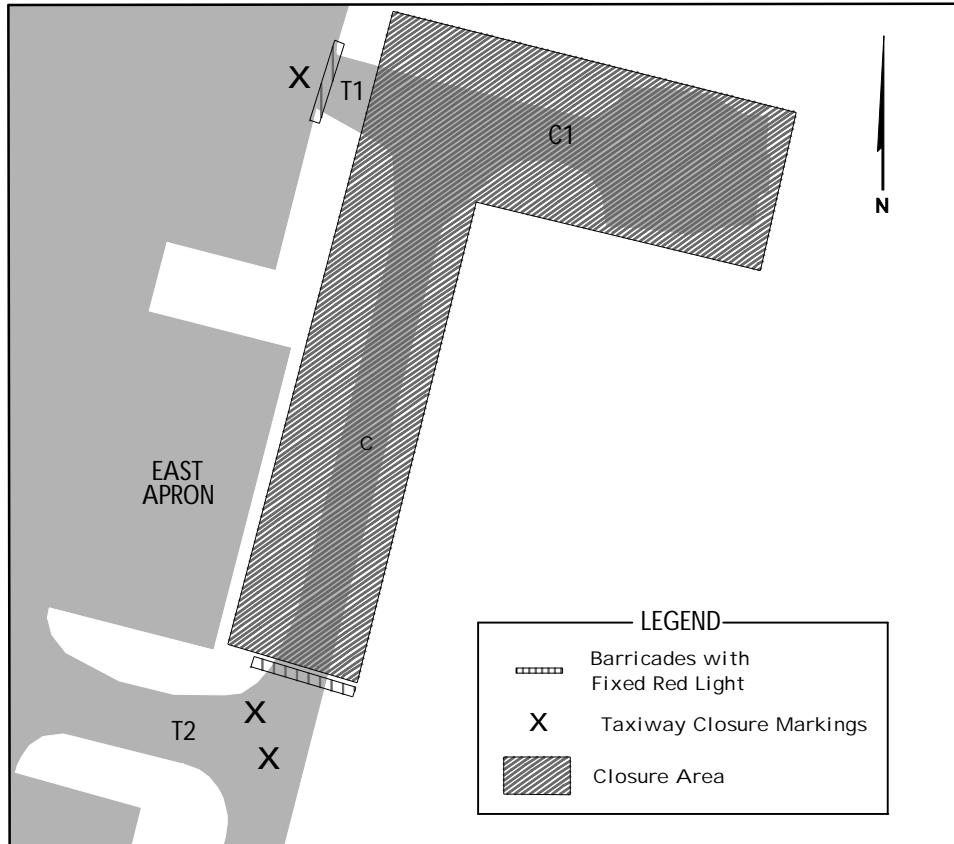

VTBS/BKK



 17 MAR 23 (20-8C) .Eff.23.Mar.

BANGKOK, THAILAND

SUARNABHUMI INTL

THE CLOSURE OF TAXIWAY E BETWEEN TAXIWAY E13 AND TAXIWAY E19, TAXIWAY E15 AND OPERATIONAL RESTRICTIONS OF RUNWAY 01L/19R AT SUARNABHUMI INTERNATIONAL AIRPORT (SUP A10/23 AIRAC)

1. INTRODUCTION

With effect from 23 March 2023 at 0000 UTC to 9 August 2023 at 2359 UTC, the purpose of these charts is to inform all concerned regarding the closure of Taxiway E between Taxiway E13 and Taxiway E19, Taxiway E15 and operational restrictions of Runway 01L/19R during the construction of Taxiway D extension at Suvarnabhumi International Airport.

2. DETAILS**2.1 THE CLOSURE OF TAXIWAYS**

As a result of the construction of Taxiway D extension, the following taxiways will be closed:

- Taxiway E between Taxiway E13 and Taxiway E19,
- Taxiway E15.

2.2 MARKINGS AND LIGHTING

The details of markings and lighting on associated areas are as follows:

- Closure markings (yellow crosses) are displayed on a closed portion of taxiways.
- Taxiway centre line lights, taxiway edge lights and taxiway signage leading to and on Taxiway E between Taxiway E13 and Taxiway E19, Taxiway E15 will be unserviceable.
- Rapid exit taxiway indicator lights (RETILs) for exit Taxiway E15 will be unserviceable.
- The closure area will be blocked off by 3'(1m) frangible barricades painted in alternate band of red and white, barricades will be lighted by omni-directional fixed red lights spacing every 10'(3m) at night and during limited visibility conditions.

Construction Area

- The distance between taxiway centre line and the objects (fences with fixed red lights) on Taxiway E between Taxiway E13 and Taxiway E19 is 33'(10m).
- All construction areas will be blocked off by construction fences.
- The dimension of fences is 10'(3m) high painted in alternate band of red and white, fences will be lighted by omni-directional fixed red lights spacing every 25'(7.5m) at night and during limited visibility condition.
- Jet blast fences are installed parallel to the construction fences at Taxiway E19. The dimension of fences is 8'(2.5m) high painted in alternate band of red and white.
- Stop bar Taxiway E5 will be unserviceable.

2.3 OPERATIONAL RESTRICTIONS

During the closure of Taxiway E between Taxiway E13 and Taxiway E19, and Taxiway E15, all aircraft shall use Runway 19R or Runway 01L under restrictions, as follows:

2.3.1 Runway 19R:

- Arriving aircraft are expected to exit the runway via Taxiway E9 or E13.
- In case aircraft are expected to vacate the runway other than exit Taxiway E9 or E13, pilot shall advise Bangkok Approach as soon as practicable to apply additional spacing on final approach in order to minimize the possibility of "GO-AROUND".
- If unable to vacate via Taxiway E9 or E13, pilot shall continue taxi on the runway and vacate via Taxiway E19. After vacating, pilot shall TURN RIGHT onto Taxiway E21 and hold short of Runway 19R.

2.3.2 Runway 01L:

- All departing aircraft will be instructed to enter the runway via Taxiway E5 and taxi on the runway and vacate via Taxiway E19 then TURN RIGHT onto Taxiway E21 and hold short of Runway 01L.

3. OTHERS

- 3.1 During construction period, pilots are advised to take precautions when operating near the construction areas.
- 3.2 There is a presence of machineries operating in the construction area which heights do not exceed the Obstacle Free Zone (OFZ).
- 3.3 Runway Preventive Maintenance Program will be notified by either NOTAM or chart.
- 3.4 Due to expected congestions and high possibilities of airborne delay, airlines are advised to avoid using Suvarnabhumi International Airport (VTBS) as the alternate aerodrome and extra fuel should be taken into account during construction period when Runway 01R/19L is closed.

4. VALIDITY



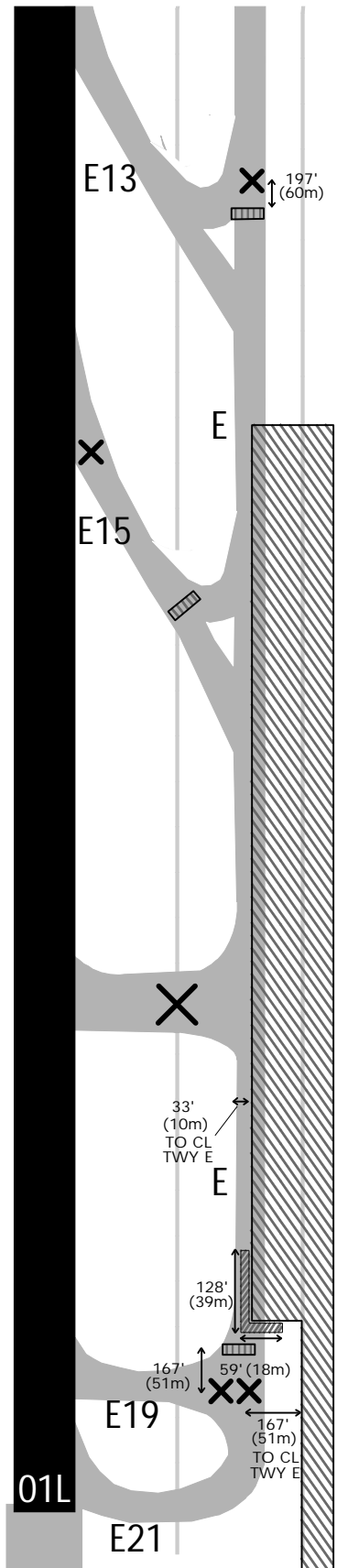

These charts will remain current until 9 August 2023 at 2359 UTC. Any changes of these charts will be notified by NOTAM.

THE CLOSURE OF TAXIWAY E BETWEEN TAXIWAY E13 AND TAXIWAY E19, TAXIWAY E15 AND OPERATIONAL RESTRICTIONS OF RUNWAY 01L/19R AT SUVARNABHUMI INTERNATIONAL AIRPORT (CONTD)

Construction Area diagram



LEGEND

-  Construction Area with Fences
-  Jet Blast Fences
-  Barricades
-  Closure marking

THE VISUAL DOCKING GUIDANCE SYSTEM (VDGS) UPGRADING AT SUVARNABHUMI INTERNATIONAL AIRPORT (SUP A017/22)

1. INTRODUCTION

With effect from 23 September 2022 at 0100 UTC to 28 February 2023 at 1700 UTC, the purpose of this chart is to inform all aircraft operators and pilots that Suvarnabhumi International Airport is going to upgrade the Visual Docking Guidance System (VDGS) to the new Advanced Visual Docking Guidance System (A-VDGS) which is more efficient and improved safety.

2. DETAILS AND IMPACT OF WORKS

- 2.1 The Visual Docking Guidance System (VDGS) will be replaced with the new Advanced Visual Docking Guidance System (A-VDGS) for 105 aircraft stands. However, the former VDGS is still used for aircraft stands 101 thru 114 (14 aircraft stands).
- 2.2 The Visual Docking Guidance System (VDGS) will be gradually closed by groups as shown in item 3.
- 2.3 To facilitate and for safety reason, the aircraft stands will be closed during the work activities and notified by NOTAM.
- 2.4 The activated date and time, for each group of the new Advanced Visual Docking Guidance System (A-VDGS) will be notified by NOTAM.

3. THE SCHEDULE OF WORK ACTIVITIES

The areas, aircraft stands, unserviceable date and time, activated date and time of VDGS operations are described below:

AREAS	VDGS OF AIRCRAFT STANDS	UNSERVICEABLE DATE (UTC)	UNSERVICEABLE TIME (UTC)	ACTIVATED DATE AND TIME (UTC)
GROUP 1				
Remote stand	115, 116, 117, 118, 119, 120	23 September 2022	01.00	Notified by NOTAM
	121, 122, 123, 124, 125, 201			
	202, 203, 301, 302, 303, 304			
	305, 306, 307, 308, 401, 402			
	403, 516, 517, 518, 519, 520			
	521, 522, 523, 524, 525			
GROUP 2				
Concourse C	C1, C2, C3, C4, C5	23 September 2022	01.00	Notified by NOTAM
	C6, C7, C8, C9, C10			
Concourse D	D1, D2, D3, D4			
	D5, D6, D7, D8			
Concourse E	E1, E2, E3, E4, E5			
	E6, E7, E8, E9, E10			
GROUP 3				
Concourse F	F1, F3, F5	17 October 2022	01.00	Notified by NOTAM
	F2, F4, F6	21 October 2022		
Concourse A	A1, A2, A3	26 October 2022		
	A4, A5, A6	31 October 2022		
Concourse B	B1, B3, B5	4 November 2022		
	B2, B4, B6	9 November 2022		
Concourse G	G1, G2, G3	14 November 2022		
	G4, G5	18 November 2022		
GROUP 4				
Remote stand	126, 127, 128	23 December 2022	01.00	Notified by NOTAM
	129, 502, 503	28 December 2022		
	501, 504, 505	2 January 2023		
	506, 507, 508	6 January 2023		
	509, 510, 511	11 January 2023		
	512, 513, 514	16 January 2023		
	515	20 January 2023		

4. OTHERS

- 4.1 The aircraft are strongly advised to strictly follow the Marshaller's signal in the aircraft stands in which the VDGS is unserviceable.
- 4.2 The schedule of work activities/operations may be revised in the event of forecast or actual adverse weather conditions or other extenuating circumstances.
- 4.3 Any change of the closure program will be promulgated by NOTAM.

5. VALIDITY

This chart will remain current until 28 February 2023 at 1700 UTC. Any changes to this chart will be notified by NOTAM.

THE NEW ADVANCED VISUAL DOCKING GUIDANCE SYSTEM (A-VDGS) AT SUVARNABHUMI INTERNATIONAL AIRPORT (SUP A018/22)

1. INTRODUCTION

With effect from 23 September 2022 at 0100 UTC, the purpose of these charts is to inform all aircraft operators and pilots of the new Advanced Visual Docking Guidance System (A-VDGS) at Suvarnabhumi International Airport which will be replaced for 105 aircraft stands. However, the former VDGS is still used for aircraft stands 101 thru 114 (14 aircraft stands). The effective date for new A-VDGS will be notified by NOTAM.

2. OPERATING INSTRUCTIONS

System overview

The RLG GIS206-2 Laser Guided Docking System is a fully automatic aircraft docking guidance system for various types of modern aircraft.

The system utilizes 2-axis laser scanning technique to track both the lateral and longitudinal positions of the incoming aircraft and guide the aircraft to the programmed stopping position. In addition, the system also has aircraft ID verification feature (OPTIONAL) to identify the incoming aircraft and check it against the one selected by the operator. If the incoming aircraft fails to match the expected aircraft, an 'ID FAIL' indication is immediately issued via display information console to both the pilot and the co-pilot.

Aircraft type, continuous closing distance, and azimuth guidance, etc., are presented on a single console clearly visible to both the pilot and copilot, simultaneously. Figure A shows the Aircraft Display console, mounted on the terminal in front of the aircraft stand.

The system is operated only in the automatic mode. If the system fails, the aircraft must then be marshalled into the stand manually.

Figure A

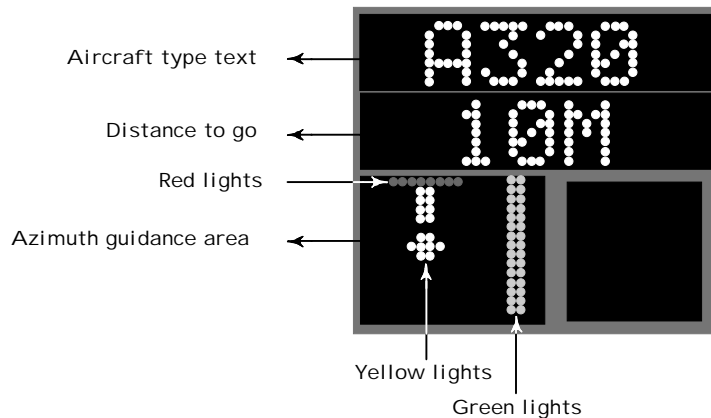

3. DOCKING PROCEDURE





The new Advanced Visual Docking Guidance System (A-VDGS)

The pilot display of a new Advanced Visual Docking Guidance System (A-VDGS) is shown below:

	<p>3.1 Parking sequence: In this picture the aircraft is at a distance greater than 30 metres from the parking position and is directly at the centre line.</p> <p>Note that the progress bar and digital close-in distance are not displayed when the aircraft is greater than 30 metres away from the docking position.</p> <p>An Airbus 320 aircraft is expected.</p>
	<p>In this picture the aircraft is at exactly 30 metres from the docking position, but is off to the right of the centre line.</p> <p>Starting at 30 metres, the digital close-in distance (second line of display) is displayed, in 1 metre decrements.</p> <p>The progress meter (lower left) will also be activated at this distance.</p>

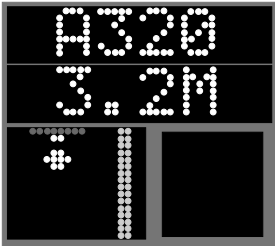

THE NEW ADVANCED VISUAL DOCKING GUIDANCE SYSTEM (A-VDGS)
AT SUVARNABHUMI INTERNATIONAL AIRPORT (contd)

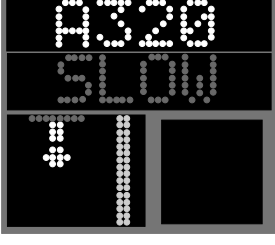
DOCKING PROCEDURE (contd)

	<p>The aircraft is at 20 metres from the docking position and has returned to the centre line.</p> <p>Note the position of progress meter. The arrow will advance one position every 2.5 metres.</p>
	<p>In this picture the aircraft is at 10 metres and is on the centre line</p>
	<p>The aircraft is now at 3.2 metres from the docking position and has again veered off to the left of centre line.</p> <p>Note that at below 5 metres, the close-in distance is displayed in 0.2 metre decrements.</p>
	<p>Finally the aircraft is perfectly parked at the stop position, and perfectly centred.</p> <p>The word "STOP" is displayed in red. Note also the merging of the arrow and the stop line on the progress meter.</p>
	<p>The word "OK" is displayed in yellow.</p> <p>Docking is successful</p>
	<p>3.2 Slow:</p> <p>During the docking process, the pilot must taxi into the aircraft stand at minimum speed. The system will display "SLOW" alternating SLOW message if the system detects the aircraft taxi speed is beyond the range of the preset speed and causing too fast for reliable detection.</p> <p>The "SLOW" message will return to close-in distance information once the aircraft speed is back to normal speed range.</p>

THE NEW ADVANCED VISUAL DOCKING GUIDANCE SYSTEM (A-VDGS)
AT SUVARNABHUMI INTERNATIONAL AIRPORT (contd)

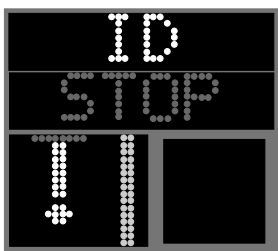
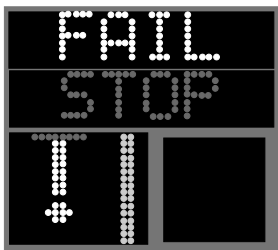
DOCKING PROCEDURE (contd)

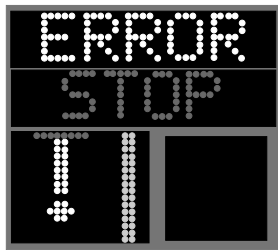
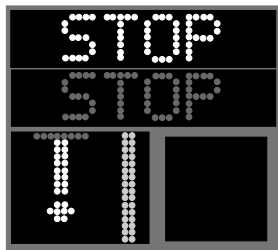
 	<p>3.3 ID FAIL (OPTIONAL):</p> <p>For this aircraft type ID verification features, the incoming aircraft must be identified and verified at least 12 metres before the stopping position or otherwise, the system will display "ID FAIL" alternating ID/FAIL in the first row of the display.</p>
	<p>3.4 Too Far:</p> <p>If the aircraft overshoots the preset range, the word "TooFar" will be displayed.</p> <p>The second row of the docking screen will indicate "STOP".</p> <p>The aircraft shall stop immediately</p>
	<p>3.5 Error Stop:</p> <p>The system will display "Error" message as indicated if the system detects any hardware error that might affect the normal docking process.</p> <p>The second row of the display will indicate "STOP" and no aircraft is to be allowed to march in until the maintenance personnel has rectified the issue.</p>
	<p>3.6 Emergency Stop:</p> <p>The first and second row of the display will show "STOP".</p> <p>The docking is aborted and aircraft must be manually guided in by a marshaller.</p>

4. VALIDITY

These charts will remain in force until its contents have been incorporated in AIP Thailand. Any changes of this AIP Supplement will be notified by NOTAM.

**THE RUNWAY PREVENTIVE MAINTENANCE PROGRAM
AT SUVARNABHUMI INTERNATIONAL AIRPORT
(SUP A26/22)**

1. INTRODUCTION

With effect from 16 December 2022 at 1800 UTC to 24 March 2023 at 2300 UTC, the purpose of this chart is to inform all concerned of the runway preventive maintenance program at Suvarnabhumi International Airport, to keep the runways in the optimal conditions and enhance the safety of flight operations.

2. RUNWAY PREVENTIVE MAINTENANCE PROGRAM

Runway 01R/19L and 01L/19R will be closed for preventive maintenance 2 days per week for each runway. The details are given below:

MONTH/YEAR	RUNWAY	DATE	CLOSURE PERIOD (UTC)
December 2022	01L/19R	16, 20, 23, 27, 30	18.00 - 23.00
	01R/19L	18, 21, 25, 28	18.30 - 23.00
January 2023	01L/19R	3, 6, 10, 13, 17, 20, 24, 27, 31	18.00 - 23.00
	01R/19L	1, 4, 8, 11, 15, 18, 22, 25, 29	18.30 - 23.00
February 2023	01L/19R	3, 7, 10, 14, 17, 21, 24, 28	18.00 - 23.00
	01R/19L	1, 5, 8, 12, 15, 19, 22, 26	18.30 - 23.00
March 2023	01L/19R	3, 7, 10, 14, 17, 21, 24	18.00 - 23.00
	01R/19L	1, 5, 8, 12, 15, 19, 22	18.30 - 23.00

3. RUNWAY AVAILABILITY DURING PREVENTIVE MAINTENANCE PERIODS

If the operational runway becomes unavailable or tends to be unusable, the maintenance work on the closed runway will be terminated as soon as possible to facilitate its return to services. Dependent on the work being carried out at the time, there may be a period of up to 2 hours before the closed runway is available.

4. OTHERS

4.1 Due to expected congestions and high possibilities of airborne delay, aircraft operators are advised to avoid using Suvarnabhumi International Airport (VTBS) as an alternate aerodrome and extra fuel should be taken into account when Runway 01R/19L is closed.

4.2 The runway preventive maintenance schedule may be revised in the event of forecast or actual adverse weather conditions or other extenuating circumstances.

5. VALIDITY

This chart will remain current until 24 march 2023 at 2300 UTC. Any changes to this chart will be notified through NOTAM.

VTBS/BKK



BANGKOK, THAILAND

Apt Elev 5'
N13 41.2 E100 44.9

21 FEB 20 (20-9)

SUVARNABHUMI INTL

D-ATIS Departure		SUVARNABHUMI Clearance A464 (Northbound), A464 (Southbound) B346, G458, G463, L301, L507, M502, M751, M757, P646, R474, W9, W19, W21, W31, Y6, Y8			SUVARNABHUMI Departure A1, G474, M904, N891, R201, R468, Y11, Y16	
127.65		128.7			133.8	
West Apron	SUVARNABHUMI Ground Main Apron		East Apron	Tower	SUVARNABHUMI Departure	
121.95	121.75		121.65	Rwy 01R/19L 118.2	Rwy 01L/19R 119.0	119.25

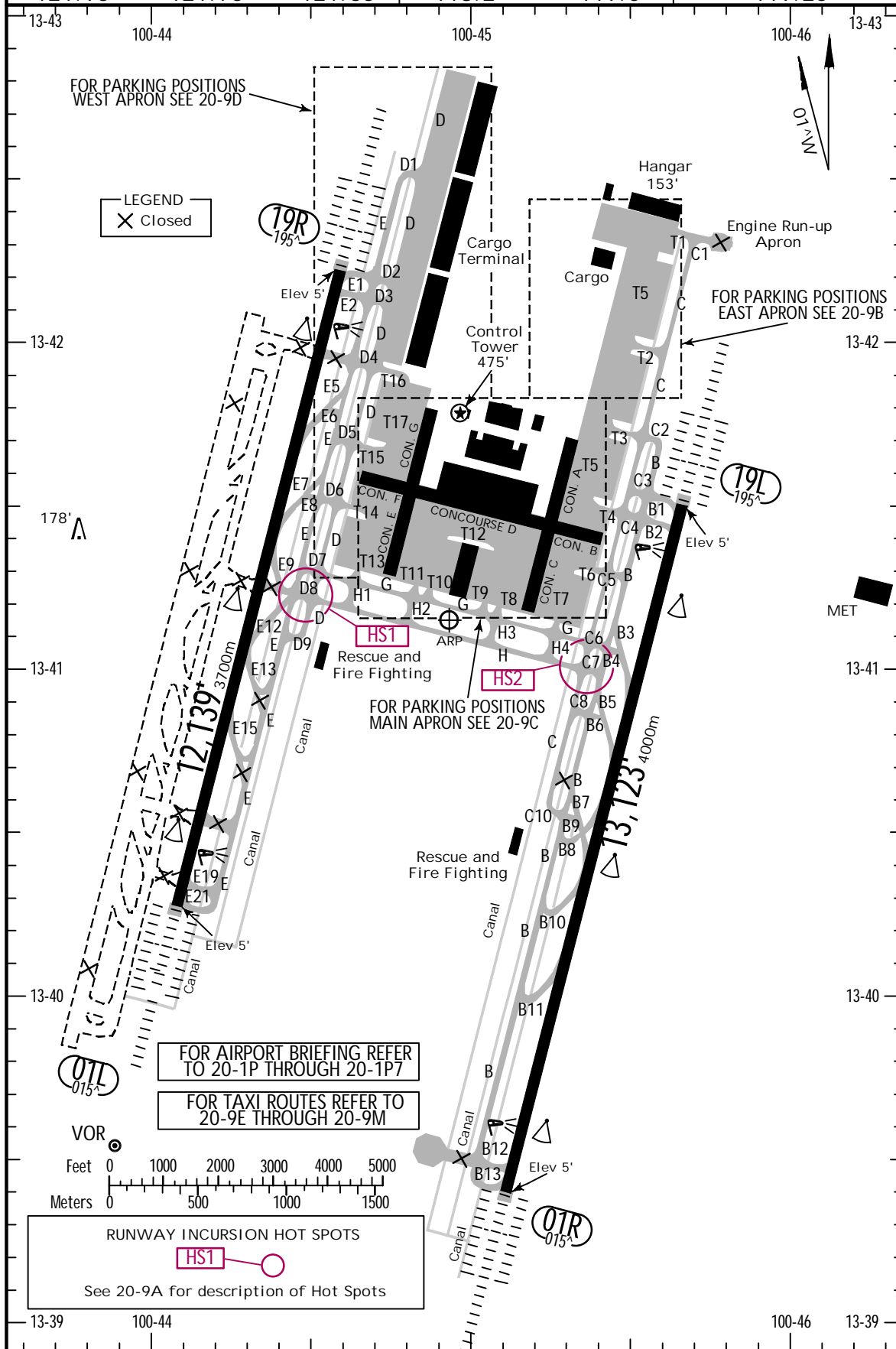

VTBS/BKK



BANGKOK, THAILAND

SUVARNABHUMI INTL

GENERAL
Birds in vicinity of airport.

ADDITIONAL RUNWAY INFORMATION							
RWY	HIRL CL ALSF-II TDZ	PAPI-L	Surface	USABLE LENGTHS		TAKE-OFF	WIDTH
				Threshold	Glide Slope		
01L 19R	HIRL CL ALSF-II TDZ	1	grooved RVR		11,075' 3376m		197' 60m
					11,069' 3374m		
1 Angle 3.0°							
01R 19L	HIRL CL ALSF-II TDZ	PAPI-L (angle 3.0°)	RVR		12,056' 3675m		197' 60m
					12,061' 3676m		

RUNWAY INCURSION HOT SPOTS HS1

For information only, not to be construed as ATC instructions.

HS1 Due to several intersections around this area which connect to rapid exit taxiways, all aircraft are required to hold, as instructed by ATC, at intermediate holding position marking/lights. Taxiing from Twy D8 to E for Rwy 01L requires a 90 degree turn, pilots should be aware of unintentionally executing a runway incursion through Twy E12.

HS2 Due to several intersections around this area which connect to rapid exit taxiways, all aircraft are required to hold, as instructed by ATC, at intermediate holding position marking/lights. Taxiing from Twy C7 to B for Rwy 01R requires a 90 degree turn, pilots should be aware of unintentionally executing a runway incursion through Twy B5.

TAKE-OFF						
ALL Rwys						
AIR CARRIER			AIR CARRIER (FAR 121)			
LVP must be in force			CL & RCLM any RVR out, other two required		Adequate Vis Ref	
RL & CL	RCLM (DAY only) or RL	RCLM (DAY only) or RL				
A	RVR 200m (150m)	RVR 250m	RVR 400m	2 Eng	TDZ RVR 175m Mid RVR 175m Roll out RVR 175m	RVR 500m VIS 400m
B				3 & 4 Eng		
C	RVR 250m (200m)	RVR 300m	RVR 400m			
D						

RVR in parentheses if TDZ RVR is supplemented by Mid and/or Rollout RVR.

VTBS/BKK



BANGKOK, THAILAND

6 MAR 20 (20-9B)

SUVARNABHUMI INTL

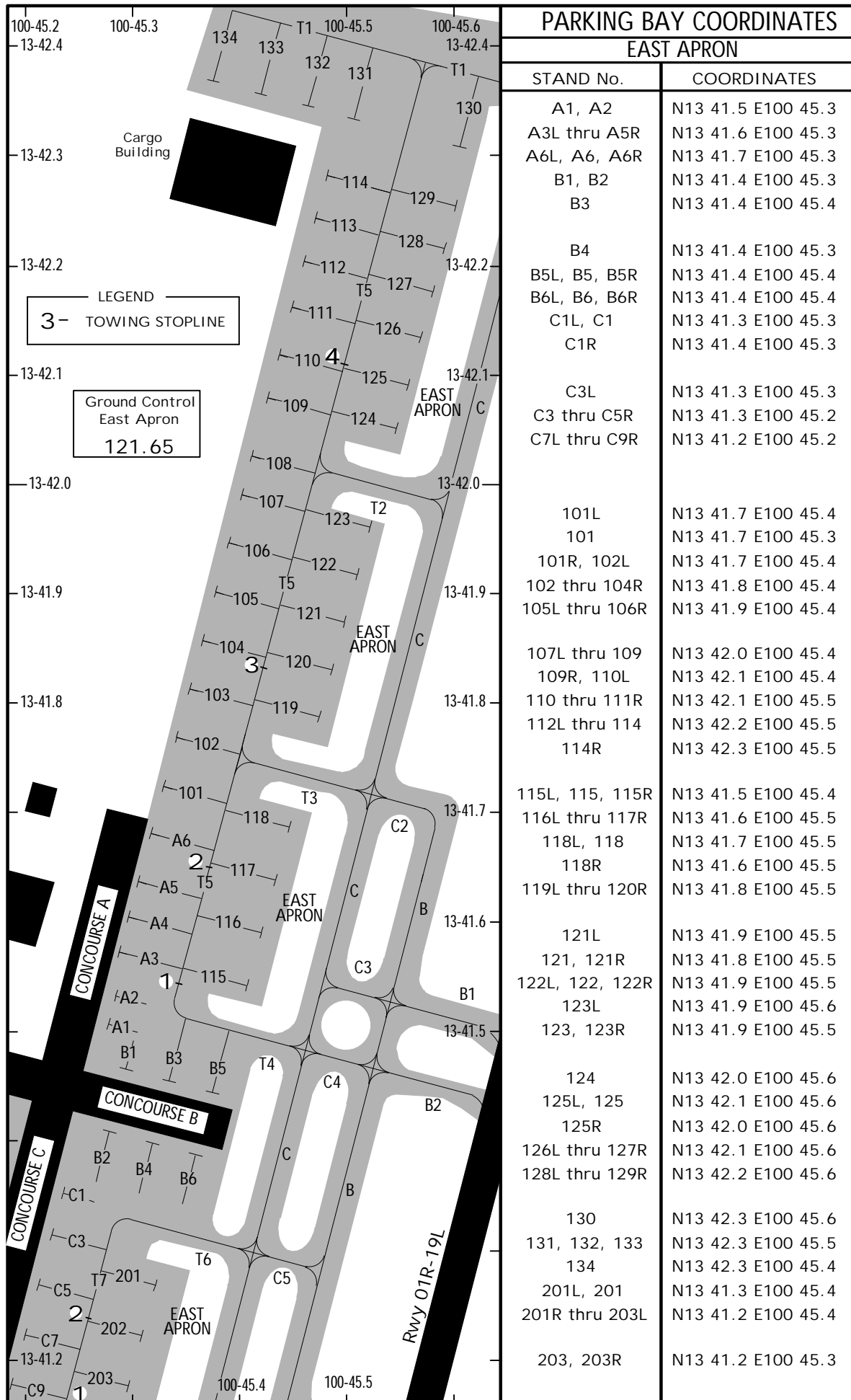

PARKING BAY COORDINATES	
EAST APRON	
STAND No.	COORDINATES
A1, A2	N13 41.5 E100 45.3
A3L thru A5R	N13 41.6 E100 45.3
A6L, A6, A6R	N13 41.7 E100 45.3
B1, B2	N13 41.4 E100 45.3
B3	N13 41.4 E100 45.4
B4	N13 41.4 E100 45.3
B5L, B5, B5R	N13 41.4 E100 45.4
B6L, B6, B6R	N13 41.4 E100 45.4
C1L, C1	N13 41.3 E100 45.3
C1R	N13 41.4 E100 45.3
C3L	N13 41.3 E100 45.3
C3 thru C5R	N13 41.3 E100 45.2
C7L thru C9R	N13 41.2 E100 45.2
101L	N13 41.7 E100 45.4
101	N13 41.7 E100 45.3
101R, 102L	N13 41.7 E100 45.4
102 thru 104R	N13 41.8 E100 45.4
105L thru 106R	N13 41.9 E100 45.4
107L thru 109	N13 42.0 E100 45.4
109R, 110L	N13 42.1 E100 45.4
110 thru 111R	N13 42.1 E100 45.5
112L thru 114	N13 42.2 E100 45.5
114R	N13 42.3 E100 45.5
115L, 115, 115R	N13 41.5 E100 45.4
116L thru 117R	N13 41.6 E100 45.5
118L, 118	N13 41.7 E100 45.5
118R	N13 41.6 E100 45.5
119L thru 120R	N13 41.8 E100 45.5
121L	N13 41.9 E100 45.5
121, 121R	N13 41.8 E100 45.5
122L, 122, 122R	N13 41.9 E100 45.5
123L	N13 41.9 E100 45.6
123, 123R	N13 41.9 E100 45.5
124	N13 42.0 E100 45.6
125L, 125	N13 42.1 E100 45.6
125R	N13 42.0 E100 45.6
126L thru 127R	N13 42.1 E100 45.6
128L thru 129R	N13 42.2 E100 45.6
130	N13 42.3 E100 45.6
131, 132, 133	N13 42.3 E100 45.5
134	N13 42.3 E100 45.4
201L, 201	N13 41.3 E100 45.4
201R thru 203L	N13 41.2 E100 45.4
203, 203R	N13 41.2 E100 45.3

VTBS/BKK

JEPPesen

BANGKOK, THAILAND

6 MAR 20 (20-9C)

SUVARNABHUMI INTL

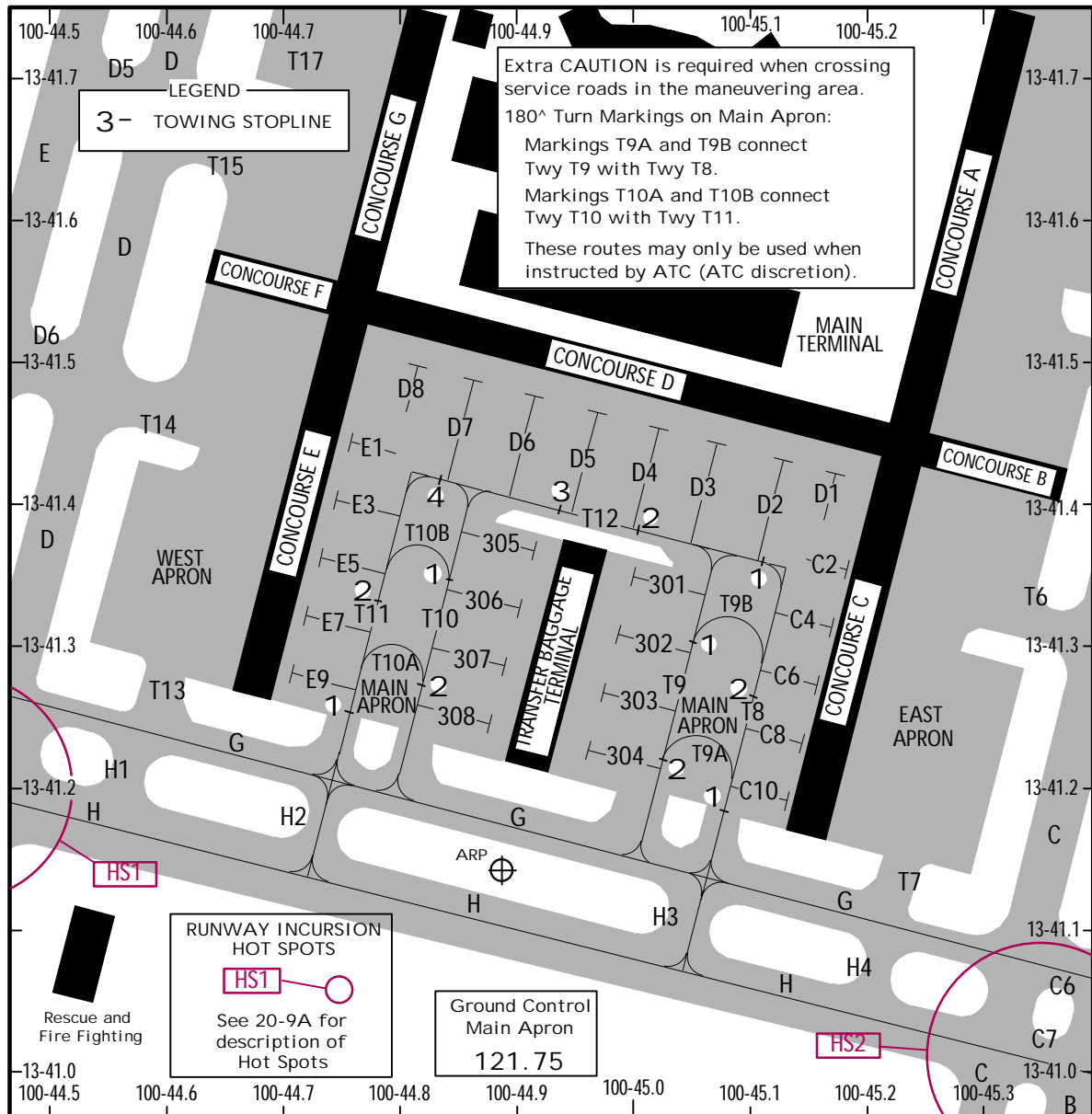

PARKING BAY COORDINATES
MAIN APRON

STAND No.	COORDINATES	STAND No.	COORDINATES
C2L, C2, C2R	N13 41.4 E100 45.2	E3, E5	N13 41.4 E100 44.8
C4L thru C8L	N13 41.3 E100 45.2	E7, E9	N13 41.3 E100 44.8
C8, C8R	N13 41.2 E100 45.2	301	N13 41.4 E100 45.0
C10L	N13 41.2 E100 45.1	302, 303	N13 41.3 E100 45.0
C10, C10R	N13 41.2 E100 45.2	304	N13 41.2 E100 45.0
D1	N13 41.4 E100 45.2	305	N13 41.4 E100 45.0
D2L thru D3R	N13 41.4 E100 45.1	306	N13 41.3 E100 45.0
D4L	N13 41.4 E100 45.0	307, 308	N13 41.3 E100 44.9
D4	N13 41.5 E100 45.0		
D4R	N13 41.5 E100 45.1		
D5	N13 41.5 E100 45.0		
D6L	N13 41.5 E100 44.9		
D6, D6R	N13 41.5 E100 45.0		
D7L thru D8	N13 41.5 E100 44.9		
E1	N13 41.5 E100 44.8		

VTBS/BKK

JEPPesen

BANGKOK, THAILAND

29 JUN 18

20-9D

SUVARNABHUMI INTL

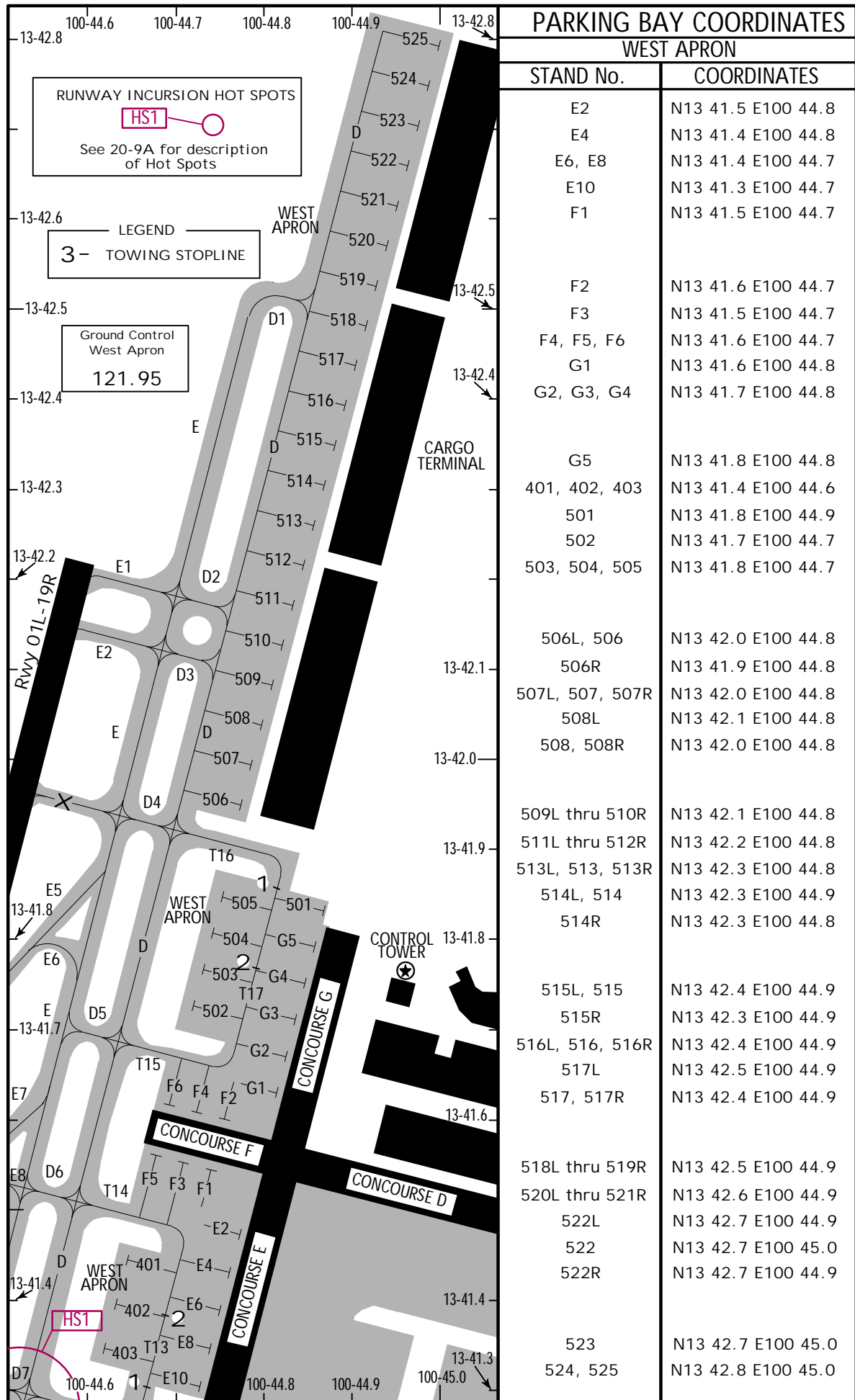

CHANGES: Towing Stoptines.

JEPPesen, 2006, 2018. ALL RIGHTS RESERVED.

VTBS/BKK



JEPPESEN
28 AUG 15 (20-9E)

BANGKOK, THAILAND
SUVARNABHUMI INTL
TAXI ROUTES ARRIVALS Rwy 01L

D-ATIS	SUVARNABHUMI Tower		Ground		
133.6	Rwy 01L/19R 119.0	Rwy 01R/19L 118.2	West Apron 121.95	Main Apron 121.75	East Apron 121.65

RUNWAY INCURSION HOT SPOTS

 See 20-9A for description of Hot Spots

LEGEND

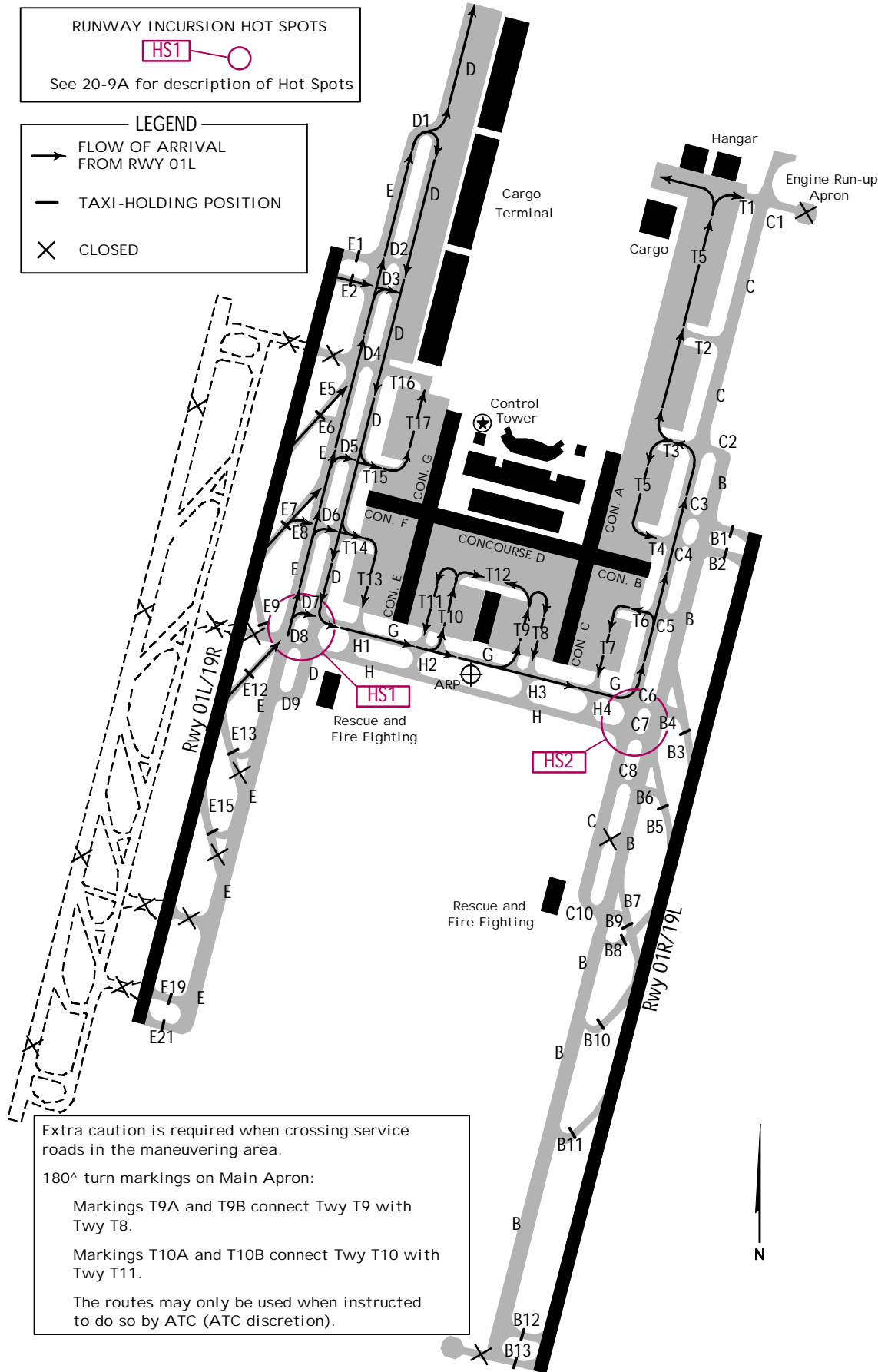
-  FLOW OF ARRIVAL FROM RWY 01L
-  TAXI-HOLDING POSITION
-  CLOSED



Extra caution is required when crossing service roads in the maneuvering area.

180° turn markings on Main Apron:

- Markings T9A and T9B connect Twy T9 with Twy T8.
- Markings T10A and T10B connect Twy T10 with Twy T11.

The routes may only be used when instructed to do so by ATC (ATC discretion).

VTBS/BKK

JEPPESEN
28 AUG 15 20-9F



BANGKOK, THAILAND

SUVARNABHUMI INTL
TAXI ROUTES DEPARTURES Rwy 01L

D-ATIS	SUVARNABHUMI Ground			Tower	
133.6	West Apron 121.95	Main Apron 121.75	East Apron 121.65	Rwy 01L/19R 119.0	Rwy 01R/19L 118.2

RUNWAY INCURSION HOT SPOTS

 See 20-9A for description of Hot Spots

LEGEND
 FLOW OF DEPARTURE TO RWY 01L
 TAXI-HOLDING POSITION
 CLOSED

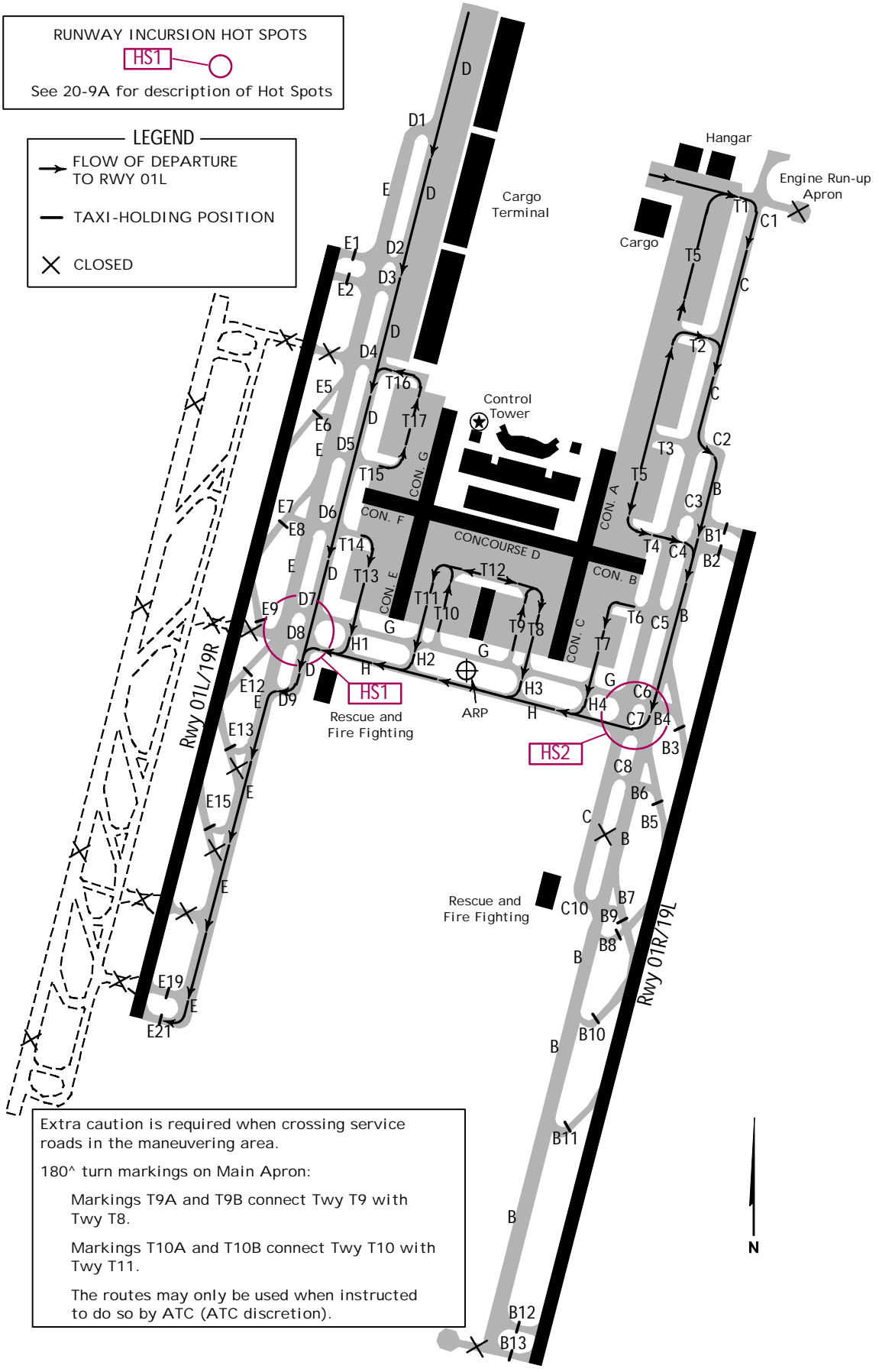

Extra caution is required when crossing service roads in the maneuvering area.
 180° turn markings on Main Apron:
 Markings T9A and T9B connect Twy T9 with Twy T8.
 Markings T10A and T10B connect Twy T10 with Twy T11.
 The routes may only be used when instructed to do so by ATC (ATC discretion).

VTBS/BKK

JEPPESEN
28 AUG 15 (20-9G)



BANGKOK, THAILAND
SUVARNABHUMI INTL
TAXI ROUTES ARRIVALS Rwy 01R

D-ATIS	SUVARNABHUMI Tower		Ground		
133.6	Rwy 01R/19L 118.2	Rwy 01L/19R 119.0	West Apron 121.95	Main Apron 121.75	East Apron 121.65

RUNWAY INCURSION HOT SPOTS

 See 20-9A for description of Hot Spots

LEGEND

-  FLOW OF ARRIVAL FROM RWY 01R
-  TAXI-HOLDING POSITION
-  CLOSED

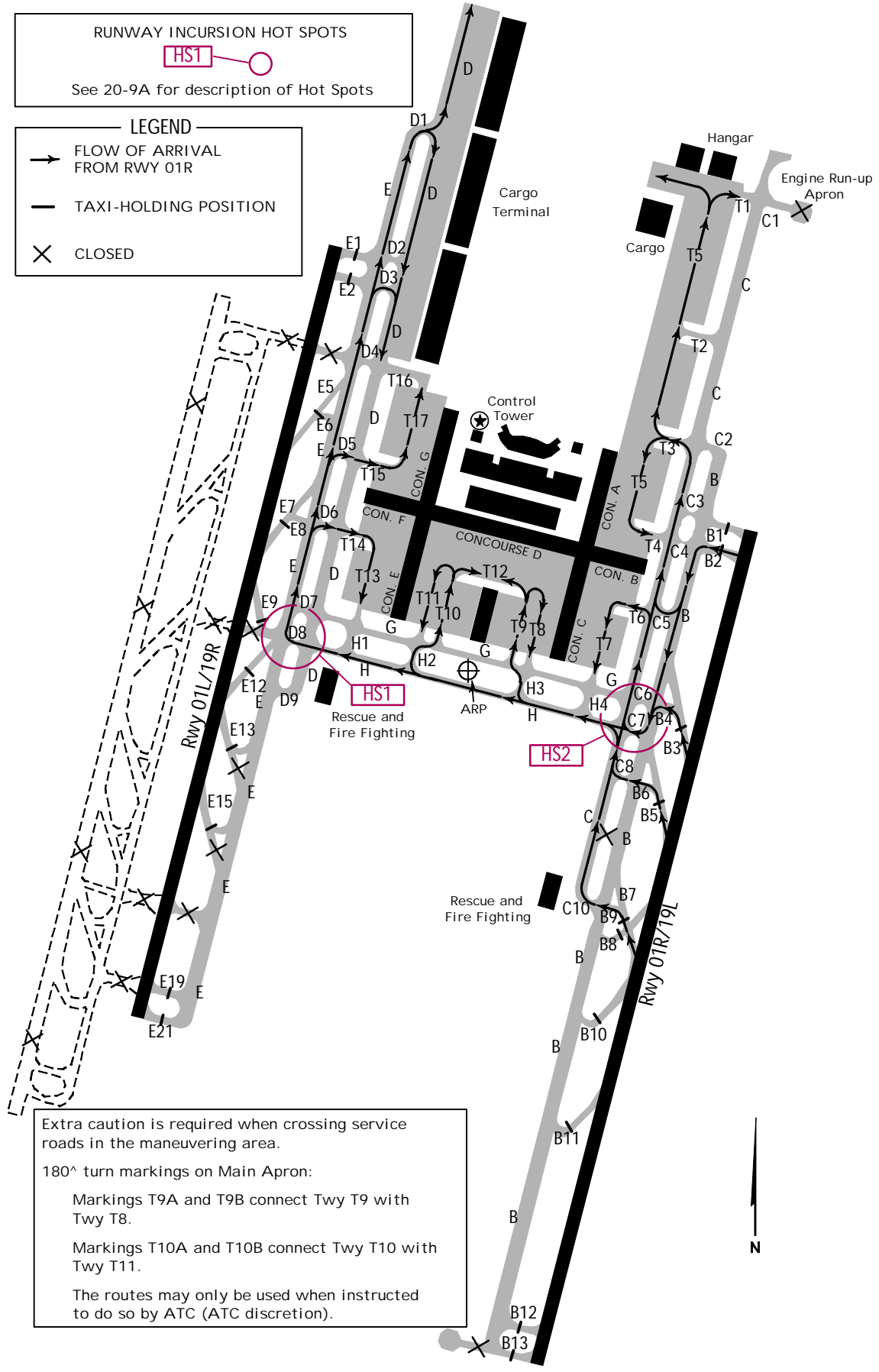

Extra caution is required when crossing service roads in the maneuvering area.

180° turn markings on Main Apron:

- Markings T9A and T9B connect Twy T9 with Twy T8.
- Markings T10A and T10B connect Twy T10 with Twy T11.

The routes may only be used when instructed to do so by ATC (ATC discretion).

VTBS/BKK

JEPPESEN

BANGKOK, THAILAND

28 AUG 15 20-9H

SUVARNABHUMI INTL

TAXI ROUTES DEPARTURES Rwy 01R

D-ATIS	SUVARNABHUMI Ground			Tower	
133.6	West Apron	Main Apron	East Apron	Rwy 01R/19L	Rwy 01L/19R
	121.95	121.75	121.65	118.2	119.0

RUNWAY INCURSION HOT SPOTS

HS1

See 20-9A for description of Hot Spots

LEGEND

FLOW OF DEPARTURE TO RWY 01R

TAXI-HOLDING POSITION

CLOSED

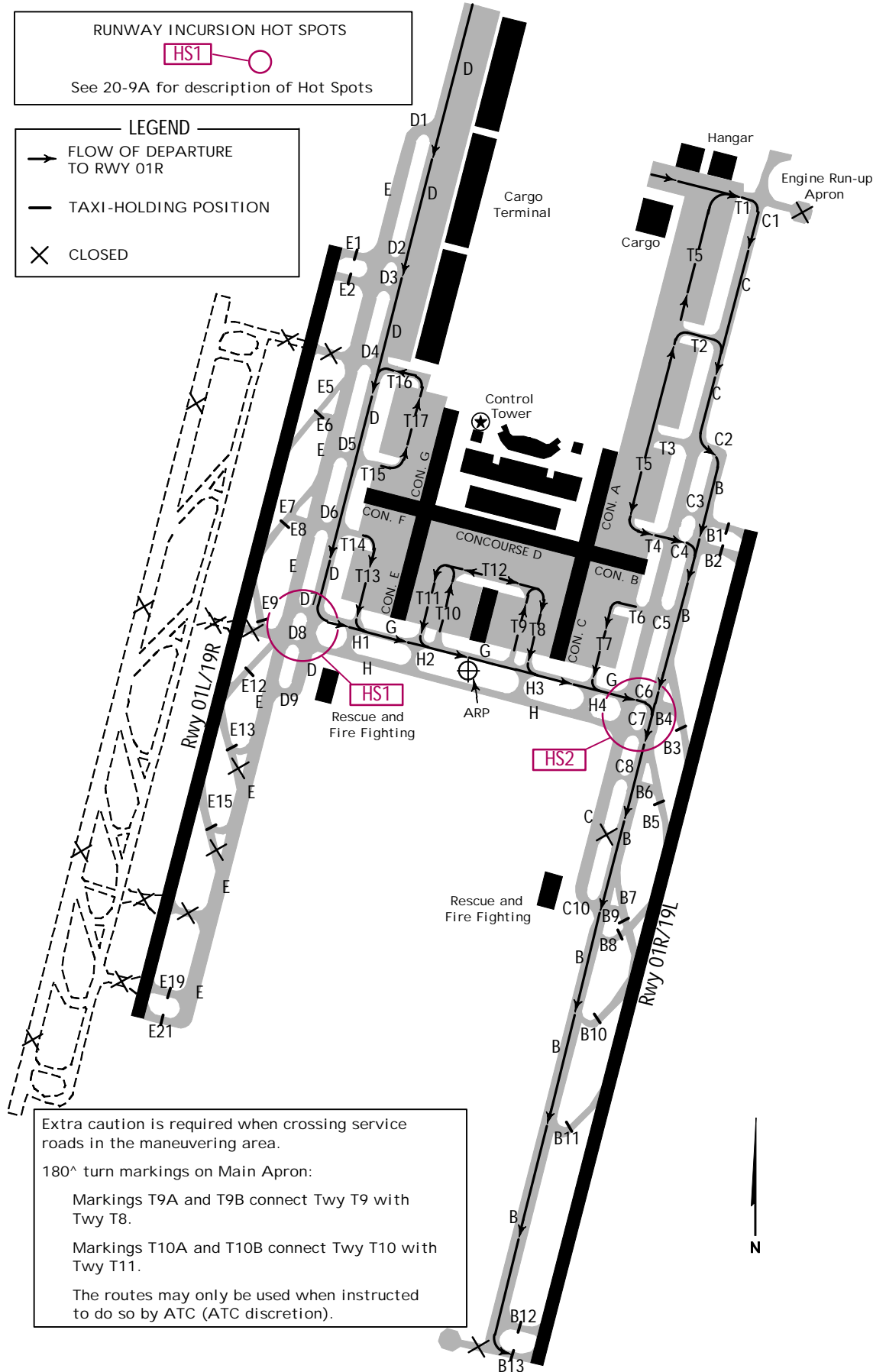

Extra caution is required when crossing service roads in the maneuvering area.

180° turn markings on Main Apron:

Markings T9A and T9B connect Twy T9 with Twy T8.

Markings T10A and T10B connect Twy T10 with Twy T11.

The routes may only be used when instructed to do so by ATC (ATC discretion).



VTBS/BKK

JEPPESEN
28 AUG 15 (20-9J)

BANGKOK, THAILAND
SUVARNABHUMI INTL
TAXI ROUTES ARRIVALS Rwy 19L

D-ATIS 133.6	SUVARNABHUMI Tower Rwy 01R/19L 118.2	Rwy 01L/19R 119.0	West Apron 121.95	Ground Main Apron 121.75	East Apron 121.65
-----------------	--	----------------------	----------------------	-----------------------------	----------------------

RUNWAY INCURSION HOT SPOTS

 See 20-9A for description of Hot Spots

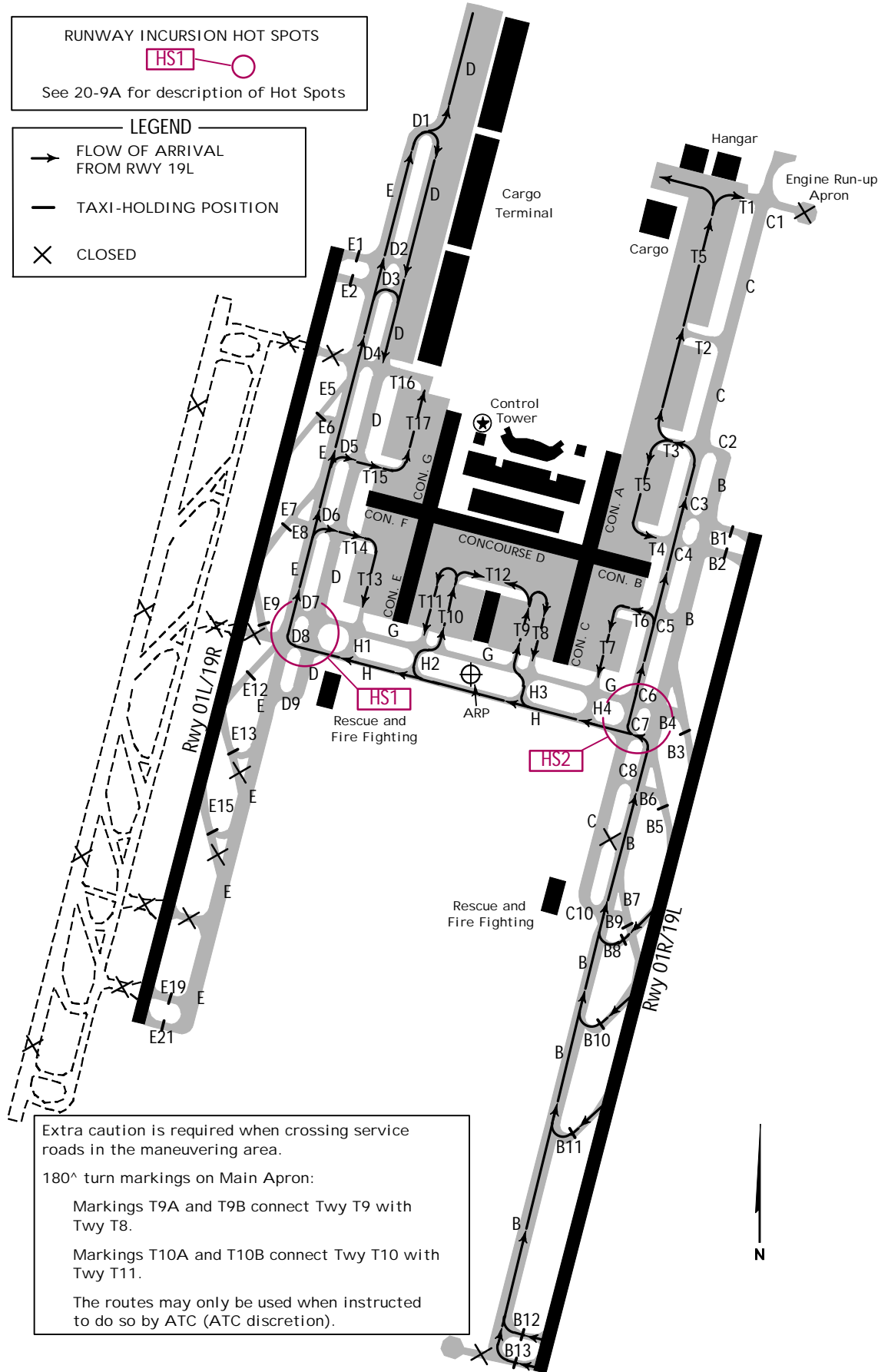
LEGEND
 FLOW OF ARRIVAL FROM RWY 19L
 TAXI-HOLDING POSITION
 CLOSED



Extra caution is required when crossing service roads in the maneuvering area.
 180° turn markings on Main Apron:
 Markings T9A and T9B connect Twy T9 with Twy T8.
 Markings T10A and T10B connect Twy T10 with Twy T11.
 The routes may only be used when instructed to do so by ATC (ATC discretion).

VTBS/BKK

JEPPESEN

BANGKOK, THAILAND

28 AUG 15 20-9K

SUVARNABHUMI INTL

TAXI ROUTES DEPARTURES Rwy 19L

D-ATIS	SUVARNABHUMI Ground			Tower	
	West Apron	Main Apron	East Apron	Rwy 01R/19L	Rwy 01L/19R
133.6	121.95	121.75	121.65	118.2	119.0

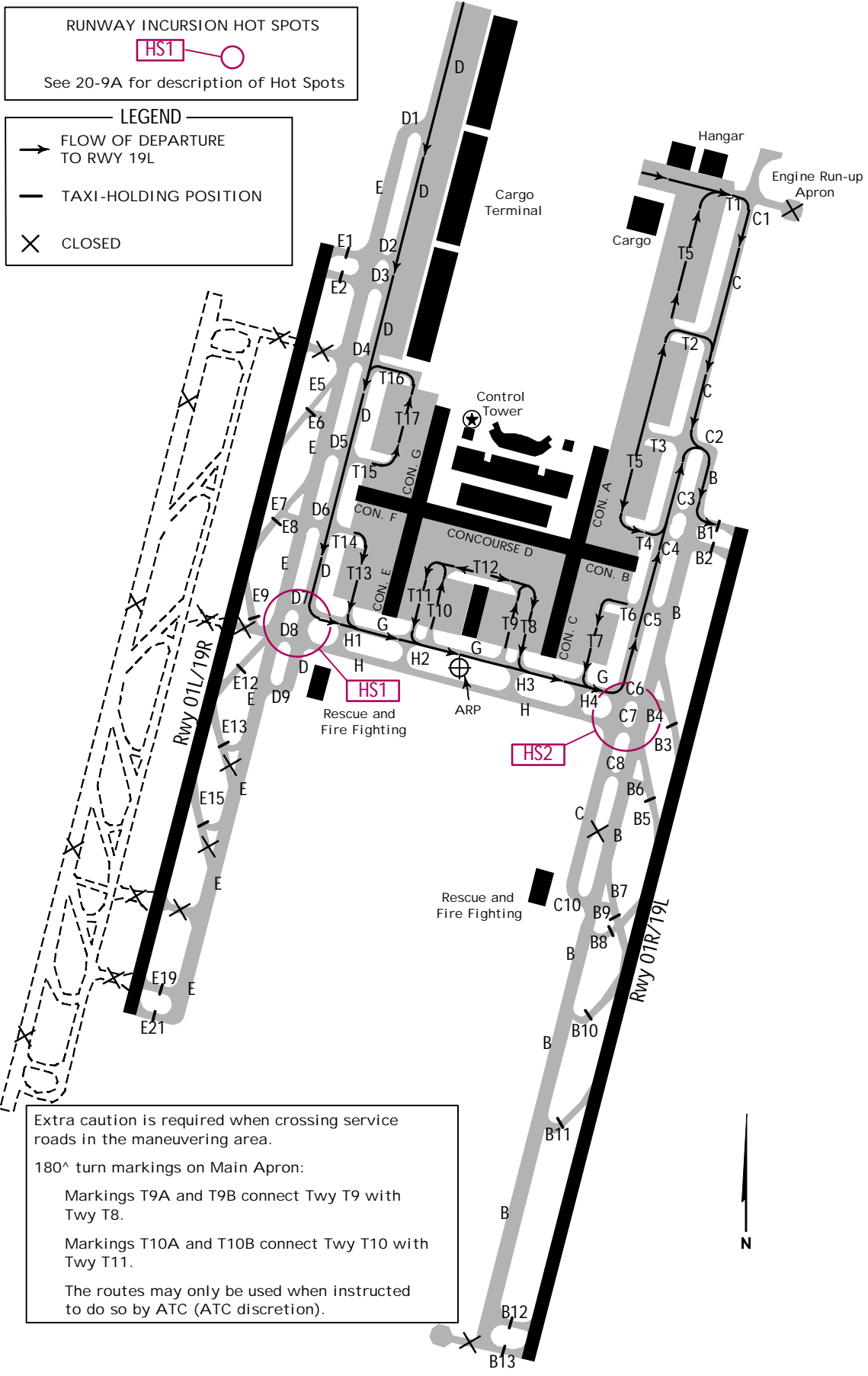

VTBS/BKK

JEPPESEN
28 AUG 15 20-9L



BANGKOK, THAILAND

SUVARNABHUMI INTL
TAXI ROUTES ARRIVALS Rwy 19R

D-ATIS 133.6	SUVARNABHUMI Tower Rwy 01L/19R 119.0	Rwy 01R/19L 118.2	West Apron 121.95	Ground Main Apron 121.75	East Apron 121.65
-----------------	--	----------------------	----------------------	-----------------------------	----------------------

RUNWAY INCURSION HOT SPOTS

 See 20-9A for description of Hot Spots

LEGEND
 FLOW OF ARRIVAL FROM RWY 19R
 TAXI-HOLDING POSITION
 CLOSED

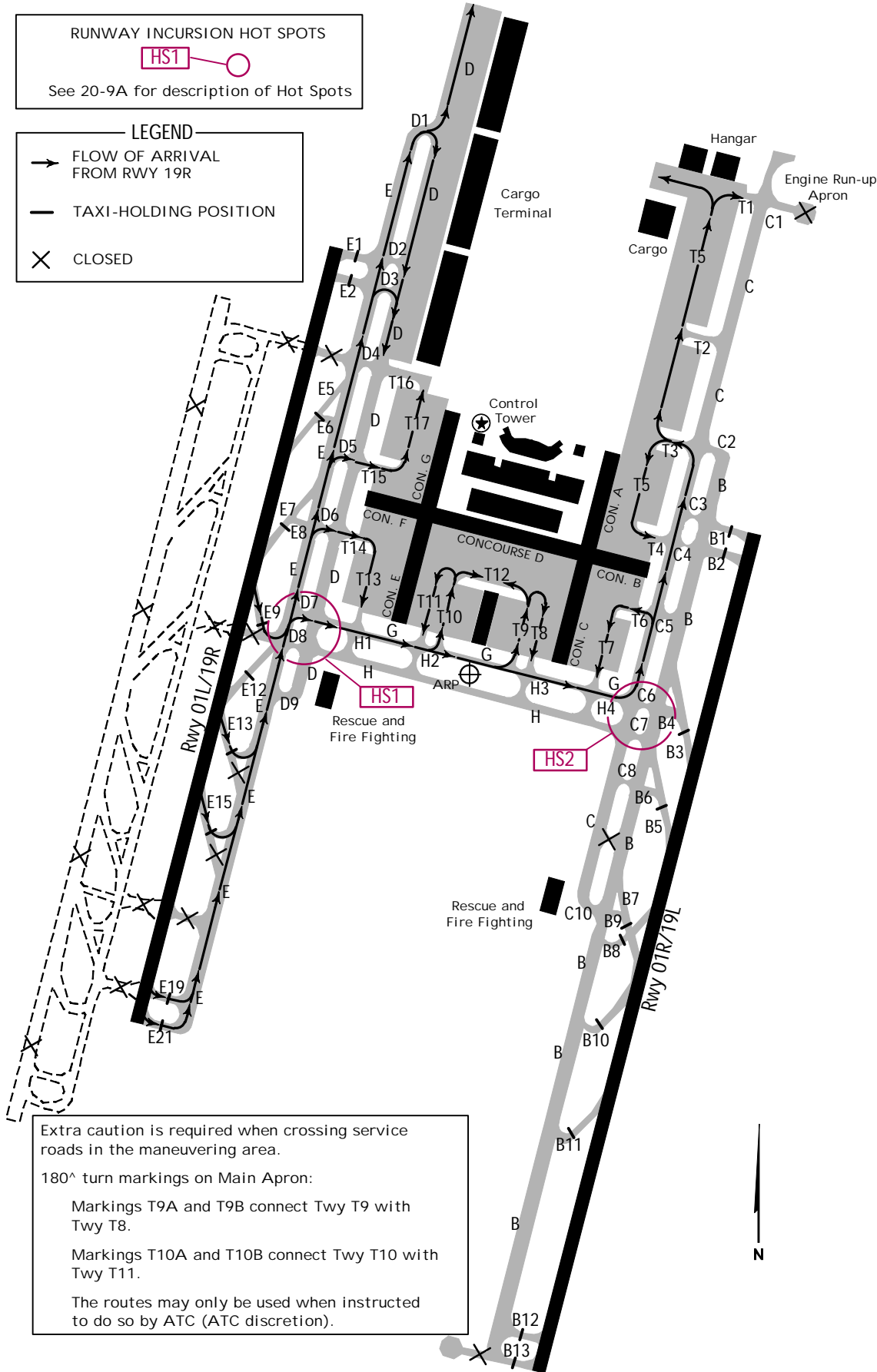

Extra caution is required when crossing service roads in the maneuvering area.
 180° turn markings on Main Apron:
 Markings T9A and T9B connect Twy T9 with Twy T8.
 Markings T10A and T10B connect Twy T10 with Twy T11.
 The routes may only be used when instructed to do so by ATC (ATC discretion).

VTBS/BKK

JEPPESEN

BANGKOK, THAILAND

28 AUG 15 (20-9M)



SUVARNABHUMI INTL

TAXI ROUTES DEPARTURES Rwy 19R

D-ATIS	SUVARNABHUMI Ground			Tower	
	West Apron	Main Apron	East Apron	Rwy 01L/19R	Rwy 01R/19L
133.6	121.95	121.75	121.65	119.0	118.2

RUNWAY INCURSION HOT SPOTS

 See 20-9A for description of Hot Spots

LEGEND

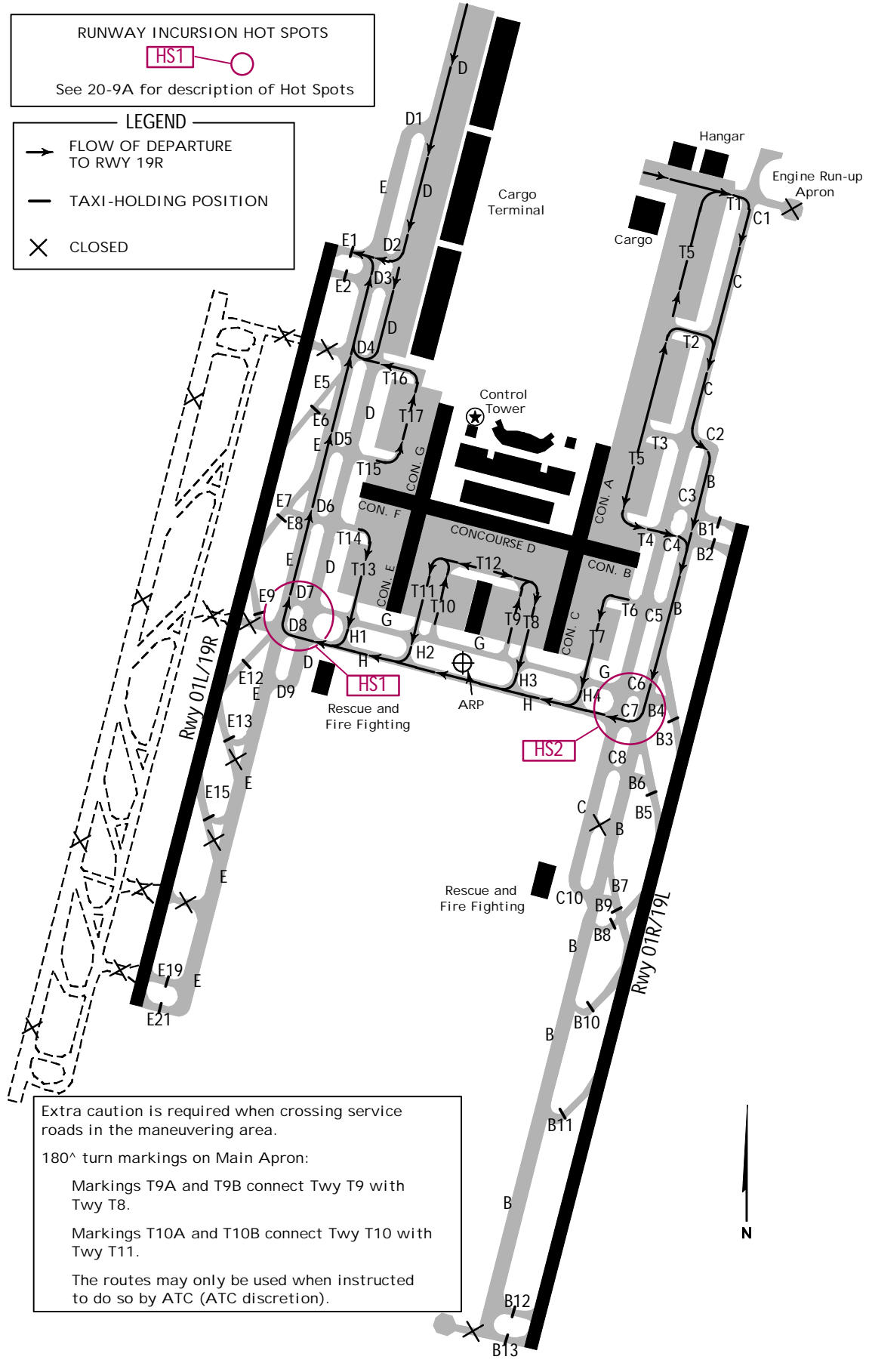
-  FLOW OF DEPARTURE TO RWY 19R
-  TAXI-HOLDING POSITION
-  CLOSED



Extra caution is required when crossing service roads in the maneuvering area.

180° turn markings on Main Apron:

- Markings T9A and T9B connect Twy T9 with Twy T8.
- Markings T10A and T10B connect Twy T10 with Twy T11.

The routes may only be used when instructed to do so by ATC (ATC discretion).

VISUAL DOCKING GUIDANCE SYSTEMS

1. SAFETY PROCEDURES

1.1 GENERAL WARNING

The VDGS System has a built-in error detection program to inform the aircraft pilot of impending dangers during the docking procedure.

IF THE PILOT IS UNSURE OF THE INFORMATION BEING SHOWN ON THE VDGS DISPLAY UNIT, HE MUST IMMEDIATELY STOP THE AIRCRAFT AND OBTAIN FUTURE INFORMATION FOR CLEARANCE.

1.2 ITEMS TO CHECK BEFORE ENTERING THE STAND AREA

WARNING: THE PILOT SHALL NOT ENTER THE STAND AREA, UNLESS THE DOCKING SYSTEM FIRST IS SHOWING THE VERTICAL RUNNING ARROWS. THE PILOT MUST NOT PROCEED BEYOND THE BRIDGE, UNLESS THESE ARROWS HAVE BEEN SUPERSEDED BY THE CLOSING RATE BAR.

WARNING: THE PILOT SHALL NOT ENTER THE STAND AREA UNLESS THE AIRCRAFT TYPE DISPLAYED IS EQUAL TO THE APPROACHING AIRCRAFT. THE CORRECTNESS OF OTHER INFORMATION, SUCH AS "DOOR 2," SHALL ALSO BE CHECKED.

1.3 THE SBU MESSAGE

The message STOP SBU means that docking has been interrupted and has to be resumed only by manual guidance. DO NOT TRY TO RESUME DOCKING WITHOUT MANUAL GUIDANCE.

1.4 OVERSHOOT PROCEDURES

Passenger loading bridges will be activated in the range as follows:

- a) between 0.01-1.50 meters are normally serviceable.
- b) between 1.51-2.00 meters, passenger loading bridge called "L1" is only serviceable, if the PLB called "L2" is required, the aircraft shall push back to correct stop-position.
- c) the distance over 2.00 meters, passenger loading bridges are unserviceable, if required the aircraft shall push back to correct stop-position.
- d) ANY OVERSHOOT DISTANCE IS MADE BY A380, PUSH BACK TO CORRECT STOP POSITION IS NEEDED WHEN PASSENGER LOADING BRIDGES ARE REQUIRED.

2. DOCKING PROCEDURE

START-OF-DOCKING

The system is started by pressing one of the aircraft type buttons on the Operator Panel. When the button has been pressed, WAIT will be displayed.

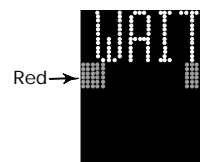

CAPTURE

The floating arrows indicate that the system is activated and in capture mode, searching for an approaching aircraft.

It shall be checked that the correct aircraft type is displayed. The lead-in line shall be followed.

THE PILOT MUST NOT PROCEED BEYOND THE BRIDGE, UNLESS THE ARROWS HAVE BEEN SUPERSEDED BY THE CLOSING RATE BAR.

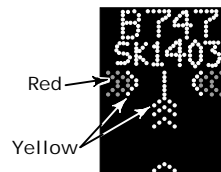

TRACKING

When the aircraft has been caught by the laser, the floating arrow is replaced by the yellow center line indicator.

A flashing red arrow indicates the direction to turn.

The vertical yellow arrow shows position in relation to the center line. This indicator gives correct position and azimuth guidance.



CLOSING RATE

Display of digital countdown will start when the aircraft is 20 meters from stop position.

When the aircraft is less than 12 meters from the stop position, the closing rate is indicated by turning off one row of the center line symbol per 0.5 meters, covered by the aircraft. Thus, when the last row is turned off, 0.5 meters remains to stop.



VISUAL DOCKING GUIDANCE SYSTEMS

DOCKING PROCEDURE (CONTD.)

ALIGNED TO CENTER

The aircraft is eight meters from the stop position. The absence of direction arrow indicates an aircraft on the center line.



SLOW DOWN

If the aircraft is approaching faster than the accepted speed, the system will show SLOW DOWN as a warning to the pilot.

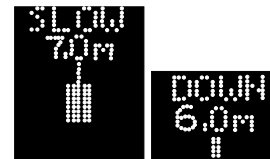

AZIMUTH GUIDANCE

The aircraft is four meters from the stop-position. The yellow arrow indicates an aircraft to the right of the center line, and the direction to turn.



STOP POSITION REACHED

When the correct stop-position is reached, the display will show STOP and red lights will be lit.



DOCKING COMPLETED

When the aircraft has parked, OK will be displayed.



OVERSHOOT

If the aircraft has overshot the stop-position, TOO FAR will be displayed for 120 seconds.



STOP SHORT

If the aircraft is found standing still but has not reached the intended stop position, the message STOP OK will be shown after a while.



WAIT

If some object is blocking the view toward the approaching aircraft or the detected aircraft is lost during docking before 12 meters to STOP, the display will show WAIT. The docking will continue as soon as the blocking object has disappeared or the system detects the aircraft again.



THE PILOT MUST NOT PROCEED BEYOND THE BRIDGE, UNLESS THE "WAIT" MESSAGE HAS BEEN SUPERSEDED BY THE CLOSING RATE BAR.

VISUAL DOCKING GUIDANCE SYSTEMS

DOCKING PROCEDURE (CONTD.)

BAD WEATHER CONDITION

During heavy fog, rain or snow, the visibility for the docking system can be reduced.

When the system is activated and in capture mode, the display will disable the floating arrows and display SLOW and the Aircraft Type.

As soon as the system detects the approaching aircraft, the vertical closing-rate bar will appear.

If the system has been configured in this mode to make a shortened ID verification (check of engine position excluded), the aircraft symbol will blink to give attention.

THE PILOT MUST NOT PROCEED BEYOND THE BRIDGE, UNLESS THE CLOSING-RATE BAR IS SHOWN.



AIRCRAFT VERIFICATION FAILURE

During entry into the stand, the aircraft geometry is being checked. If, for any reason, aircraft verification is not made 12 meters before the stop-position, the display will first show WAIT and make a second verification check. If this fails STOP and ID FAIL will be displayed. The text will be alternating on the upper two rows of the display.

THE PILOT MUST NOT PROCEED BEYOND THE BRIDGE WITHOUT MANUAL GUIDANCE, UNLESS THE WAIT MESSAGE HAS BEEN SUPERSEDED BY THE CLOSING RATE BAR.



GATE BLOCKED

If an object is found blocking the view from the DGS to the planned stop position for the aircraft, the docking procedure will be halted with a WAIT and GATE BLOCK message. The docking procedure will resume as soon as the blocking object has been removed.

THE PILOT MUST NOT PROCEED BEYOND THE BRIDGE WITHOUT MANUAL GUIDANCE, UNLESS THE WAIT MESSAGE HAS BEEN SUPERSEDED BY THE CLOSING RATE BAR.



VIEW BLOCKED

If the view towards the approaching aircraft is hindered, for instance by dirt on the window, the DGS will report a View blocked condition. Once the system is able to see the aircraft through the dirt, the message will be replaced with a closing rate display.

THE PILOT MUST NOT PROCEED BEYOND THE BRIDGE WITHOUT MANUAL GUIDANCE, UNLESS THE WAIT MESSAGE HAS BEEN SUPERSEDED BY THE CLOSING RATE BAR.



SBU-STOP

Any unrecoverable error during the docking procedure will generate an SBU (safety back-up) condition. The display will show red stop bar and the text STOP SBU.

A MANUAL BACKUP PROCEDURE MUST BE USED FOR DOCKING GUIDANCE.



VISUAL DOCKING GUIDANCE SYSTEMS

DOCKING PROCEDURE (CONTD.)

TOO FAST

If the aircraft approaches with a speed higher than the docking system can handle, the message STOP (with red squares) and TOO FAST will be displayed.

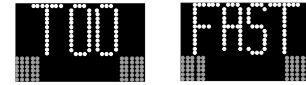

THE DOCKING SYSTEM MUST BE RE-STARTED OR THE DOCKING PROCEDURE COMPLETED BY MANUAL GUIDANCE.

EMERGENCY STOP

When the Emergency Stop button is pressed, STOP is displayed.



CHOCKS ON

CHOCK ON will be displayed, when the ground staff has put the chocks in front of the nose wheel and pressed the "Chocks On" button on the Operator Panel.



MANUAL DOCKING

When a docking is to be performed manually the system will display "MAN" on the tableau. The system will not give any guidance for the docking operation.



ERROR

If a system error occurs, the message ERROR is displayed with an error code. The code is used for maintenance purposes and explained elsewhere.



SYSTEM BREAKDOWN

In case of a severe system failure, the display will go black, except for a red stop indicator. A manual backup procedure must be used for docking guidance.

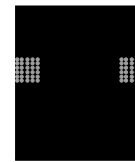

POWER FAILURE

In case of a power failure, the display will be completely black. A manual backup procedure must be used for docking guidance.



3. EMERGENCY STOP BUTTON INFORMATION

Emergency stop buttons are available at both of contact gates and remote parking stands. When unsafe situation is considered, the emergency stop button shall be pressed by bridge driver, marshaller or the ground engineer of the airline or handling agent. Emergency stop buttons are installed in the locations as follows:

- a) at the control panel in the bridge cab
- b) at the bridge rotunda
- c) at the stand identification posts

REMARK: the identification of passenger loading bridge (L1 or L2) is followed by the aircraft door positions.

VTBS/BKK
SUVARNABHUMI INTL



BANGKOK, THAILAND
ILS or LOC Z Rwy 01L

D-ATIS Arrival	SUVARNABHUMI Arrival (R)	BANGKOK Approach (R)			SUVARNABHUMI Tower		Ground		
133.6	121.1 126.3	119.1	120.3	122.35	Rwy 01L/19R	Rwy 01R/19L	West Apron	Main Apron	East Apron
		124.35	125.2	128.95	119.0	118.2	121.95	121.75	121.65

BRIEFING STRIP™

LOC ISWS 109.1	Final Apch Crs 015^	BS488 2000' (1995')	ILS DA(H) Refer to Minimums	Apt Elev 5' Rwy 5'	<p>MSA ARP</p>
<p>MISSED APCH: Climb to 3000' on course 015^ to LAINO and hold or as directed by ATC. If unable to reach 3000' at LAINO, continue climb in the holding pattern. No turn before MAP (for LOC only). Speed restricted to MAX 190 KT. Refer to minimums for missed apch climb gradient.</p>					
<p>Alt Set: hPa Rwy Elev: 0 hPa Trans level: FL 130 Trans alt: 11000'</p> <p>1. RNAV 1 required. 2. GNSS or DME/DME/IRU required. 3. RADAR required. 4. DME required.</p>					

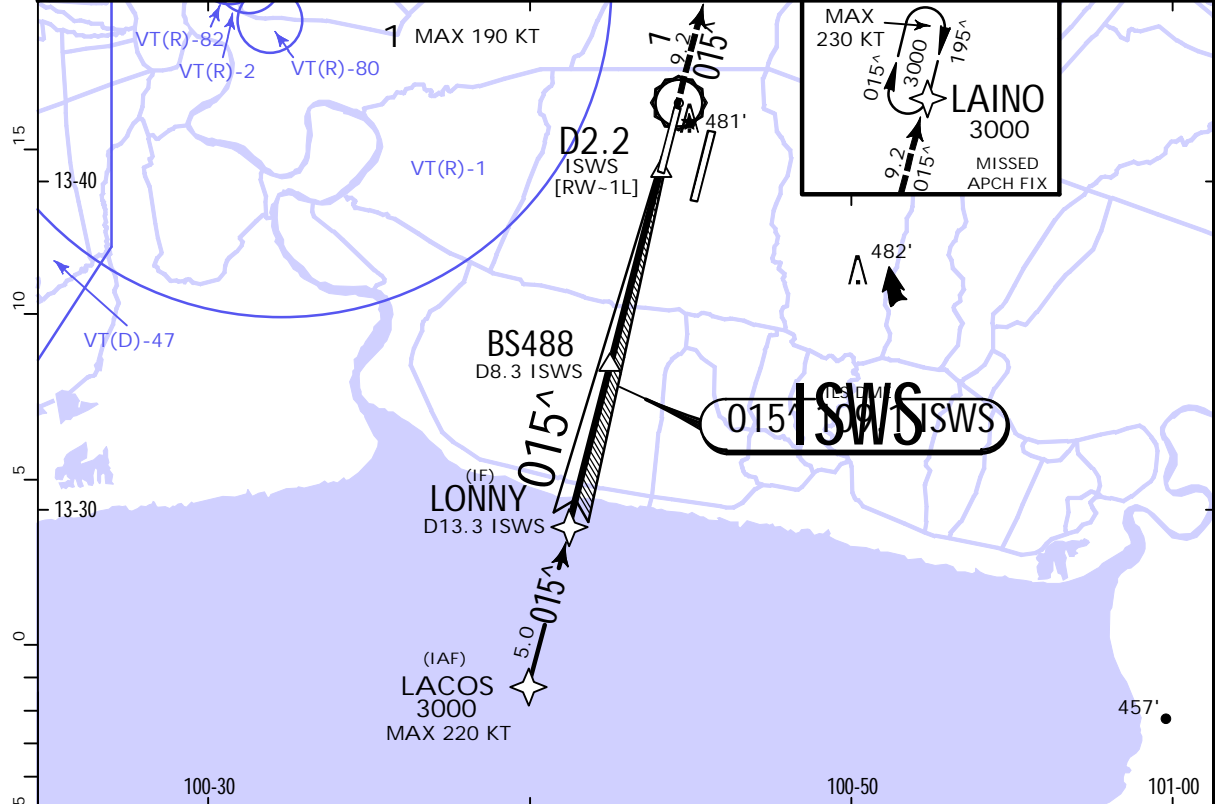

LOC (GS out)	ISWS DME	BS488	8.0	7.0	6.0	5.0	4.0	3.7
	ALTITUDE	2000'	1890'	1570'	1255'	940'	625'	530'

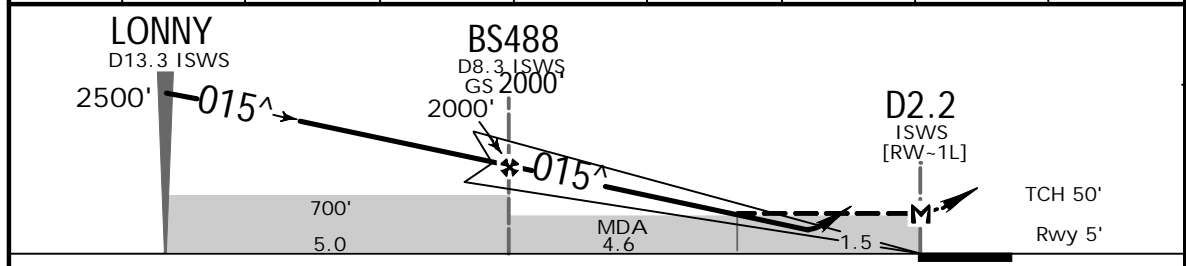

Gnd speed-Kts	70	90	100	120	140	160		3000' on 015^ course LAINO
ILS GS or LOC Descent Angle	3.00^	372	478	531	637	743		

STRAIGHT-IN LANDING RWY 01L				CIRCLE-TO-LAND			
Missed apch climb gradient mim 5.0% to 1000'				LOC (GS out)			
1 DA(H) 230' (225')		MDA(H) 530' (525')					
	FULL	TDZ/CL out	ALS out			Max Kts	MDA(H)
A				800m	1600m	100	800' (795') - 2200m
B	RVR 550m	RVR 720m	1200m	1600m	2400m	135	900' (895') - 4400m
C	VIS 800m	VIS 800m		2000m	2800m	180	900' (895') - 4400m
D						205	900' (895') - 4800m

PANS OPS

1 Procedure requires a missed approach climb gradient of 5.0% (304'/NM) until passing 1000'. For aircraft which only achieve a 2.5% (152'/NM) climb gradient, the CAT I DA(H) is 370' (365'), ALL CATS VIS : 1000m, ALS out 1800m.

VTBS/BKK

SUVARNABHUMI INTL

5 FEB 21

21-1A

JEPPESSEN

BANGKOK, THAILAND
ILS Z Rwy 01L CAT II

D-ATIS Arrival 133.6	SUVARNABHUMI Arrival (R) 121.1 126.3	BANGKOK Approach (R) 119.1 120.3 122.35 124.35 125.2 128.95			SUVARNABHUMI Tower Rwy 01L/19R 119.0 Rwy 01R/19L 118.2		Ground West Apron 121.95 Main Apron 121.75 East Apron 121.65		
LOC ISWS 109.1	Final Apch Crs 015 [^]	BS488 2000' (1995')	CAT II ILS Refer to Minimums		Apt Elev 5' Rwy 5'		 <p>MSA ARP</p>		
<p>MISSED APCH: Climb to 3000' on course 015[^] to LAINO and hold or as directed by ATC. If unable to reach 3000' at LAINO, continue climb in the holding pattern. Speed restricted to MAX 190 KT. Refer to minimums for missed apch climb gradient.</p> <p>Alt Set: hPa Rwy Elev: 0 hPa Trans level: FL 130 Trans alt: 11000'</p> <p>1. Special Aircrew and Aircraft Certification required. 2. RNAV 1 required. 3. GNSS or DME/DME/IRU required. 4. RADAR required. 5. DME required.</p>									

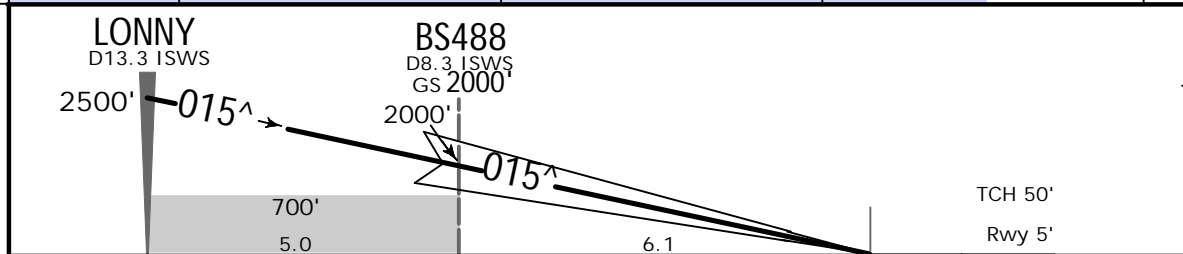

Gnd speed-Kts	70	90	100	120	140	160	ALSF-II 3000'	PAPI	↑ on 015 [^] course	LAINO
GS	3.00 [^]	372	478	531	637	743				

STRAIGHT-IN LANDING RWY 01L
Missed APCH climb gradient mim 4.0% to 1000'
CAT II ILS
RA 100'
1 DA(H) 105' (100')

RVR 350m

PANS OPS

1 Procedure requires a missed approach climb gradient of 4.0% (243' /NM) until passing 1000'.
For aircraft which only achieve a 2.5% (152' /NM) climb gradient, the CAT II DA(H) is 295' (290').

VTBS/BKK
SUVARNABHUMI INTL

JEPESEN
5 FEB 21 **(21-2)**

BANGKOK, THAILAND
ILS or LOC Y Rwy 01L

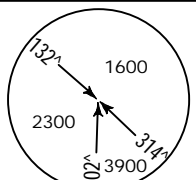
D-ATIS Arrival 133.6	SUVARNABHUMI Arrival (R) 121.1 126.3	BANGKOK Approach (R) 119.1 120.3 122.35 124.35 125.2 128.95			SUVARNABHUMI Tower Rwy 01L/19R Rwy 01R/19L 119.0 118.2	Ground West Apron Main Apron East Apron 121.95 121.75 121.65			
LOC ISWS 109.1	Final Apch Crs 015[^]	LEVIN 2000' (1995')		ILS DA(H) Refer to Minimums	Apt Elev 5' Rwy 5'		 <p>MSA SVB VOR</p>		
<p>MISSED APCH: Climb outbound on SVB VOR R-015 to 3000' and hold at D10.0 SVB, or as directed by ATC. If unable to reach 3000' at SVB VOR R-015/D10.0 SVB, continue climb in the holding pattern. Refer to minimums for missed apch climb gradient.</p>									
<p>Alt Set: hPa Rwy Elev: 0 hPa Trans level: FL 130 Trans alt: 11000'</p>									
<p>Non-RADAR procedure: Aircraft will be cleared to BKK VOR then transition to LEVIN to carry out the ILS approach.</p>									

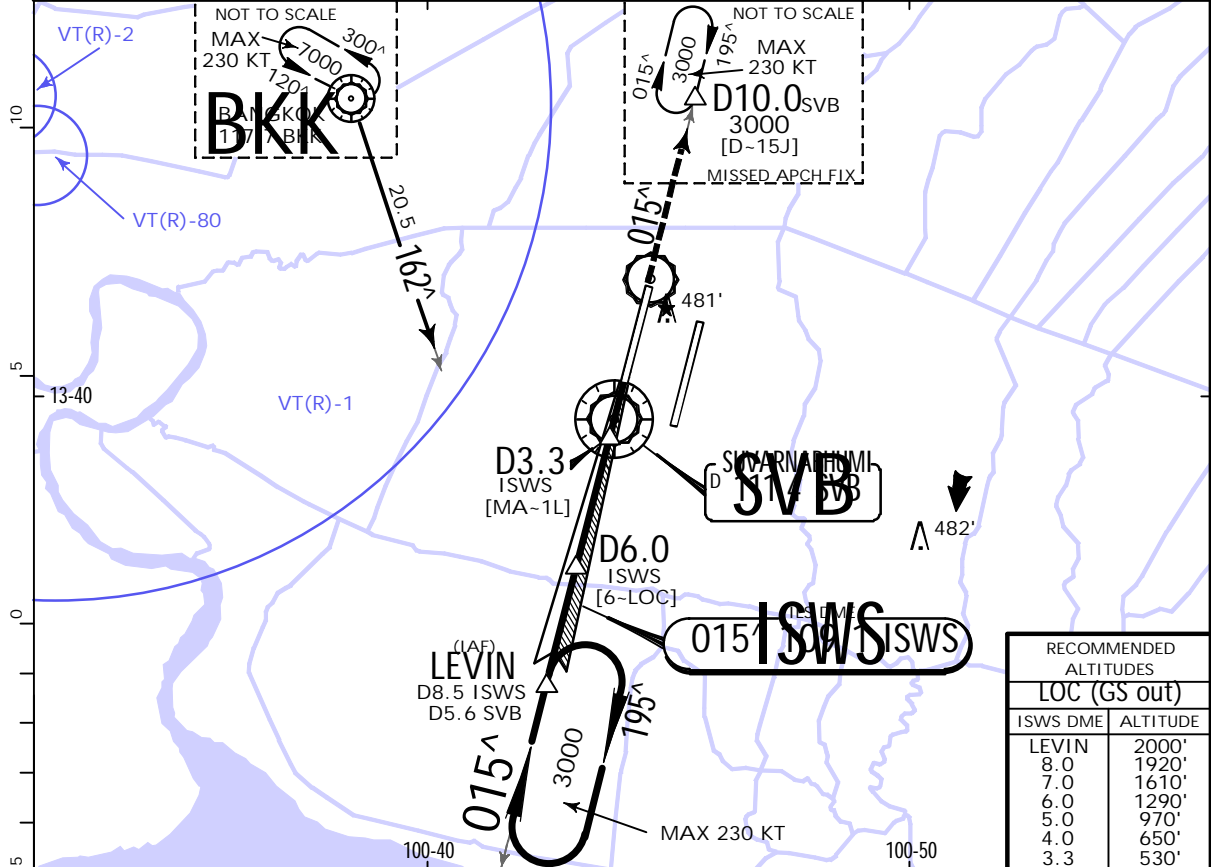

RECOMMENDED ALTITUDES	
LOC (GS out)	
ISWS DME	ALTITUDE
LEVIN	2000'
8.0	1920'
7.0	1610'
6.0	1290'
5.0	970'
4.0	650'
3.3	530'

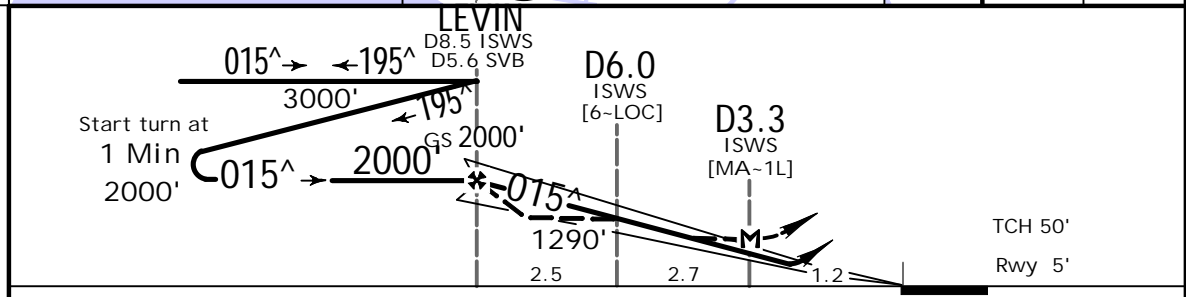

Gnd speed-Kts	70	90	100	120	140	160	 <p>3000' SVB on 111.4 R-015</p>	
ILS GS or LOC Descent Angle	3.00 [^]	372	478	531	637	743		849
MAP at D3.3 ISWS	5.2	4:27	3:28	3:07	2:36	2:14		1:57
FAF to MAP								

STRAIGHT-IN LANDING RWY 01L					CIRCLE-TO-LAND		
Missed apch climb gradient mim 5.0% to 1000'							
FULL		IDZ/CL out	ALS out	LOC (GS,out) MDA(H) 530' (525')	Max Kts	MDA(H)	
1 DA(H) 230' (225')					100	800' (795') -2200m	
A					135		
B	RVR 550m	RVR 720m	1200m	1400m	180	900' (895') -4400m	
C	vis 800m	vis 800m		1600m	205	900' (895') -4800m	
D				2000m			

Procedure requires a missed approach climb gradient of 5.0% (304'/NM) until passing 1000'. For aircraft which only achieve a 2.5% (152'/NM) climb gradient, the CAT I DA(H) is 370' (365'), ALL CATS VIS : 1000m, ALS out 1800m.

VTBS/BKK
SUVARNABHUMI INTL



BANGKOK, THAILAND
ILS Y Rwy 01L CAT II

D-ATIS Arrival	SUVARNABHUMI Arrival (R)	BANGKOK Approach (R)			SUVARNABHUMI Tower		Ground		
133.6	121.1 126.3	119.1	120.3	122.35	Rwy 01L/19R	Rwy 01R/19L	West Apron	Main Apron	East Apron
		124.35	125.2	128.95	119.0	118.2	121.95	121.75	121.65

BRIEFING STRIP™

LOC ISWS 109.1	Final Apch Crs 015^	LEVIN 2000' (1995')	CAT II ILS Refer to Minimums	Apt Elev 5' Rwy 5'
--------------------------	-------------------------------	-------------------------------	---------------------------------	-----------------------

MISSED APCH: Climb outbound on SVB VOR R-015 to 3000' and hold at D10.0 SVB, or as directed by ATC. If unable to reach 3000' at SVB VOR R-015/D10.0 SVB, continue climb in the holding pattern. Refer to minimums for missed apch climb gradient.

Alt Set: hPa Rwy Elev: 0 hPa Trans level: FL 130 Trans alt: 11000'

1. Special Aircrew and Aircraft Certification required. 2. Non-RADAR procedure: Aircraft will be cleared to BKK VOR then transition to LEVIN to carry out the ILS approach.

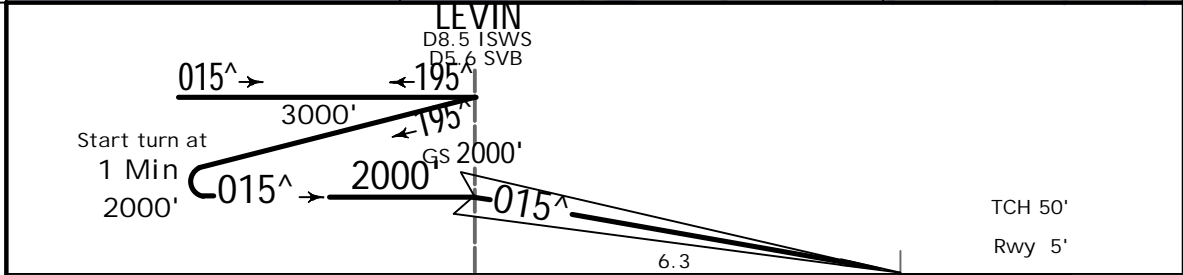
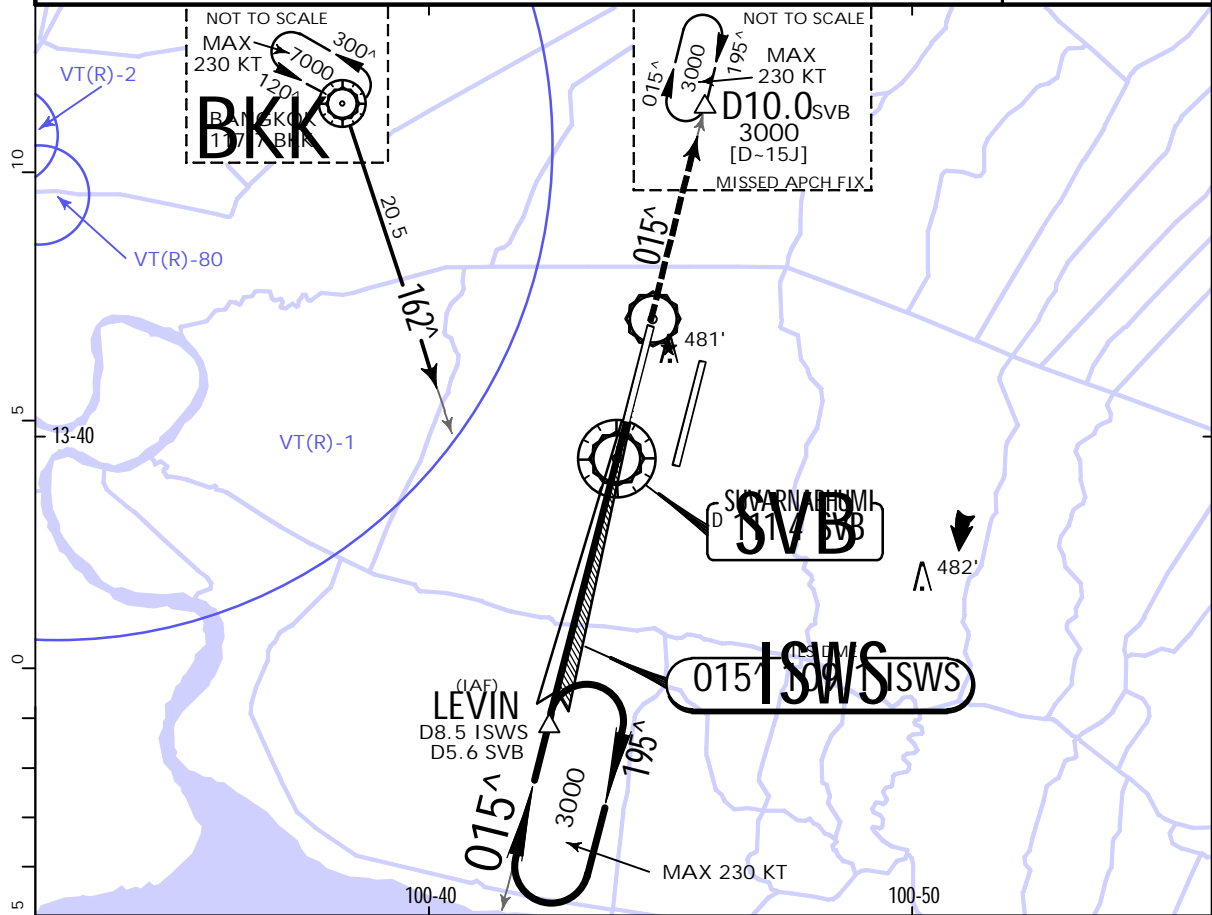
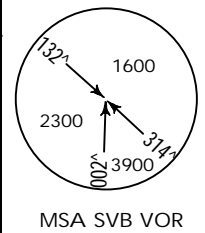

Gnd speed-Kts	70	90	100	120	140	160	ALSIF-II PAPI 3000' SVB ↑ on 111.4 R-015
Gs	3.00^	372	478	531	637	743	

STRAIGHT-IN LANDING RWY 01L
Missed APCH climb gradient mim 4.0% to 1000'
CAT II ILS
RA 100'
1 DA(H) 105' (100')

RVR 350m

PANS OPS

1 Procedure requires a missed approach climb gradient of 4.0% (243' /NM) until passing 1000'. For aircraft which only achieve a 2.5% (152' /NM) climb gradient, the CAT II DA(H) is 295' (290').

VTBS/BKK
SUVARNABHUMI INTL



BANGKOK, THAILAND
ILS or LOC Z Rwy 01R

5 FEB 21 (21-3)

D-ATIS Arrival	SUVARNABHUMI Arrival (R)	BANGKOK Approach (R)			SUVARNABHUMI Tower		Ground		
133.6	121.1 126.3	119.1	120.3	122.35	Rwy 01L/19R	Rwy 01R/19L	West Apron	Main Apron	East Apron
		124.35	125.2	128.95	119.0	118.2	121.95	121.75	121.65
LOC ISES 110.1		Final Apch Crs 015[^]		BS499 2000' (1995')	ILS DA(H) 205' (200')		Apt Elev 5' Rwy 5'		
MISSED APCH: Climb to 1000' on track 015 [^] , then climbing RIGHT turn direct to RENEX at 3000' and hold or as directed by ATC. If unable to reach 3000' at RENEX, continue climb in the holding pattern. No turn before MAP (for LOC only). Speed restricted to MAX 190 KT until after turn.									
Alt Set: hPa		Rwy Elev: 0 hPa		Trans level: FL 130		Trans alt: 11000'			
RNAV 1 required									
1. GNSS or DME/DME/IRU required. 2. RADAR required. 3. DME required.									

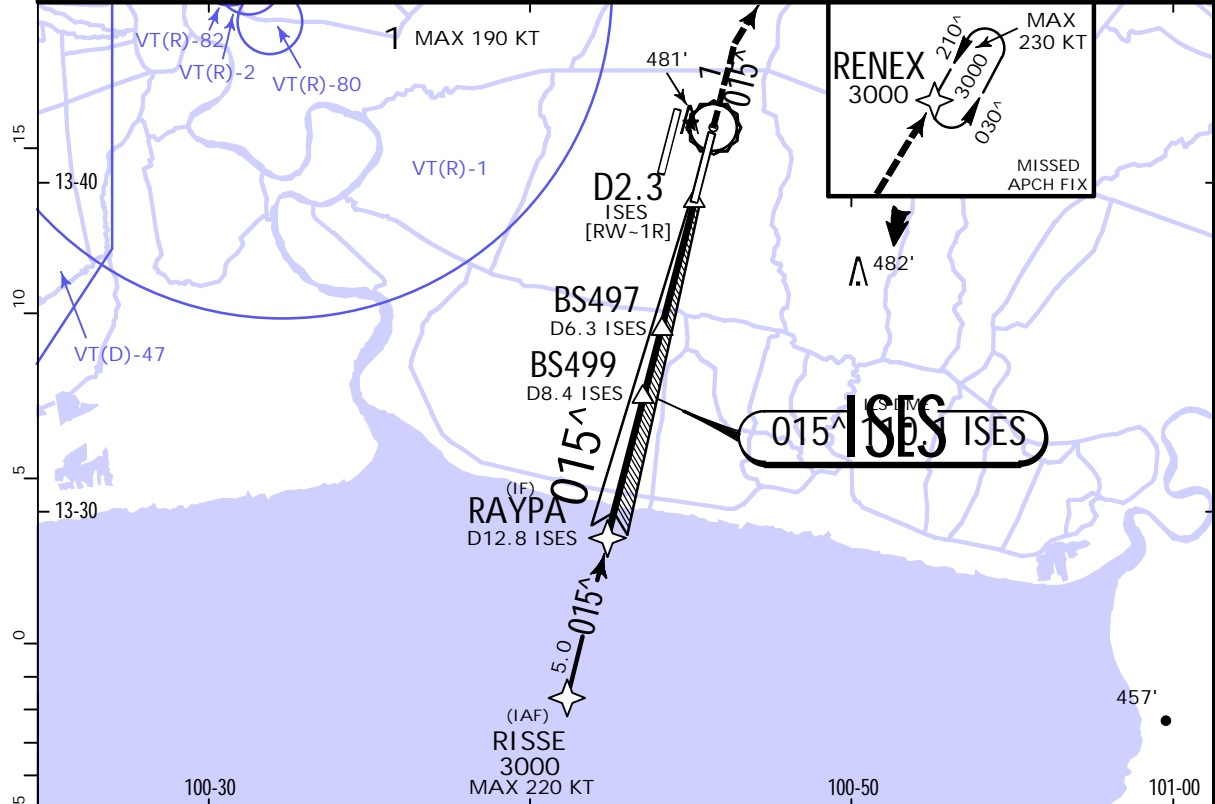
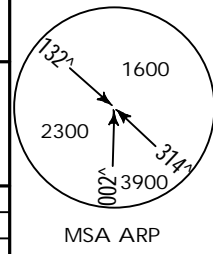

LOC (GS out)	ISES DME	BS499	8.0	7.0	6.0	5.0	4.0
	ALTITUDE	2000'	1855'	1540'	1225'	910'	600'

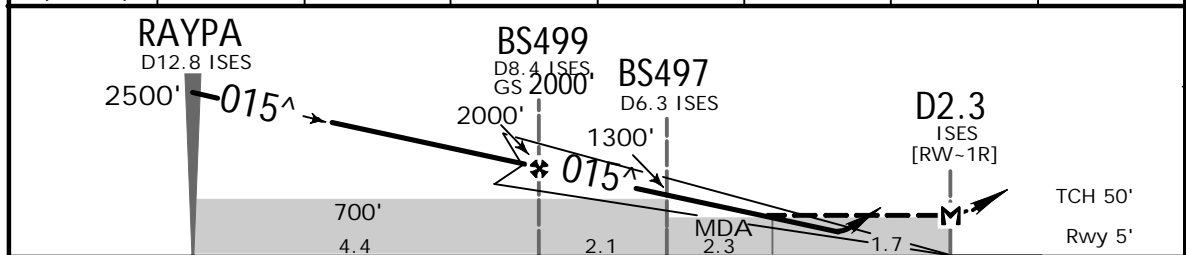

Gnd speed-Kts	70	90	100	120	140	160	ALSF-II PAPI 1000' on 015 [^] track RT RENEX	
ILS GS or LOC Descent Angle	3.00 [^]	372	478	531	637	743		849
MAP at D2.3 ISES								

STRAIGHT-IN LANDING RWY 01R				CIRCLE-TO-LAND			
ILS DA(H) 205' (200')			LOC (GS out) MDA(H) 600' (595')			Max Kts	
FULL		TDZ or CL out	ALS out	ALS out		MDA(H)	
A				800m	1600m	100	800' (795') - 1600m
B	RVR 550m	RVR 720m	1200m			135	800' (795') - 2000m
C	VIS 800m	VIS 800m		1600m	2400m	180	900' (895') - 4400m
D				2000m	2800m	205	900' (895') - 4800m

PANS OPS

VTBS/BKK
SUVARNABHUMI INTL

JEPPESSEN
5 FEB 21 (21-3A)

BANGKOK, THAILAND
ILS Z Rwy 01R CAT II

D-ATIS Arrival	SUVARNABHUMI Arrival (R)	BANGKOK Approach (R)			SUVARNABHUMI Tower		Ground		
133.6	121.1 126.3	119.1	120.3	122.35	Rwy 01L/19R	Rwy 01R/19L	West Apron	Main Apron	East Apron
		124.35	125.2	128.95	119.0	118.2	121.95	121.75	121.65

BRIEFING STRIP™

LOC ISES 110.1	Final Apch Crs 015[^]	BS499 2000' (1995')	CAT II ILS RA 100 DA(H) 105' (100')	Apt Elev 5' Rwy 5'
MISSED APCH: Climb to 1000' on track 015 [^] , then climbing RIGHT turn direct to RENEX at 3000' and hold or as directed by ATC. If unable to reach 3000' at RENEX, continue climb in the holding pattern. Speed restricted to MAX 190 KT until after turn.				
RNAV 1 required Alt Set: hPa Rwy Elev: 0 hPa Trans level: FL 130 Trans alt: 11000' 1. Special Aircrew and Aircraft Certification required. 2. GNSS or DME/DME/IRU required. 3. RADAR required. 4. DME required.				

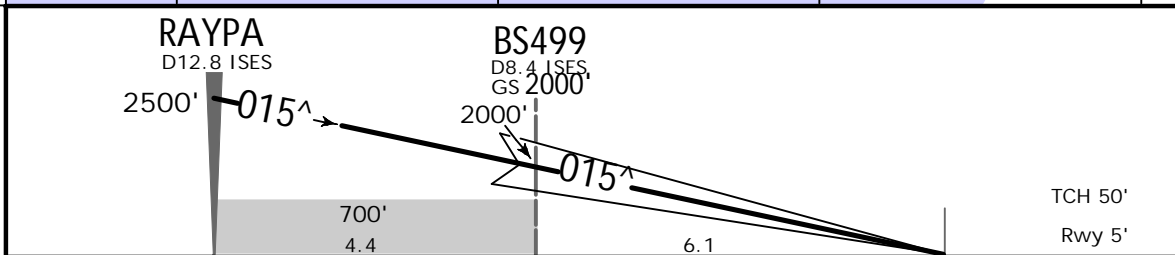
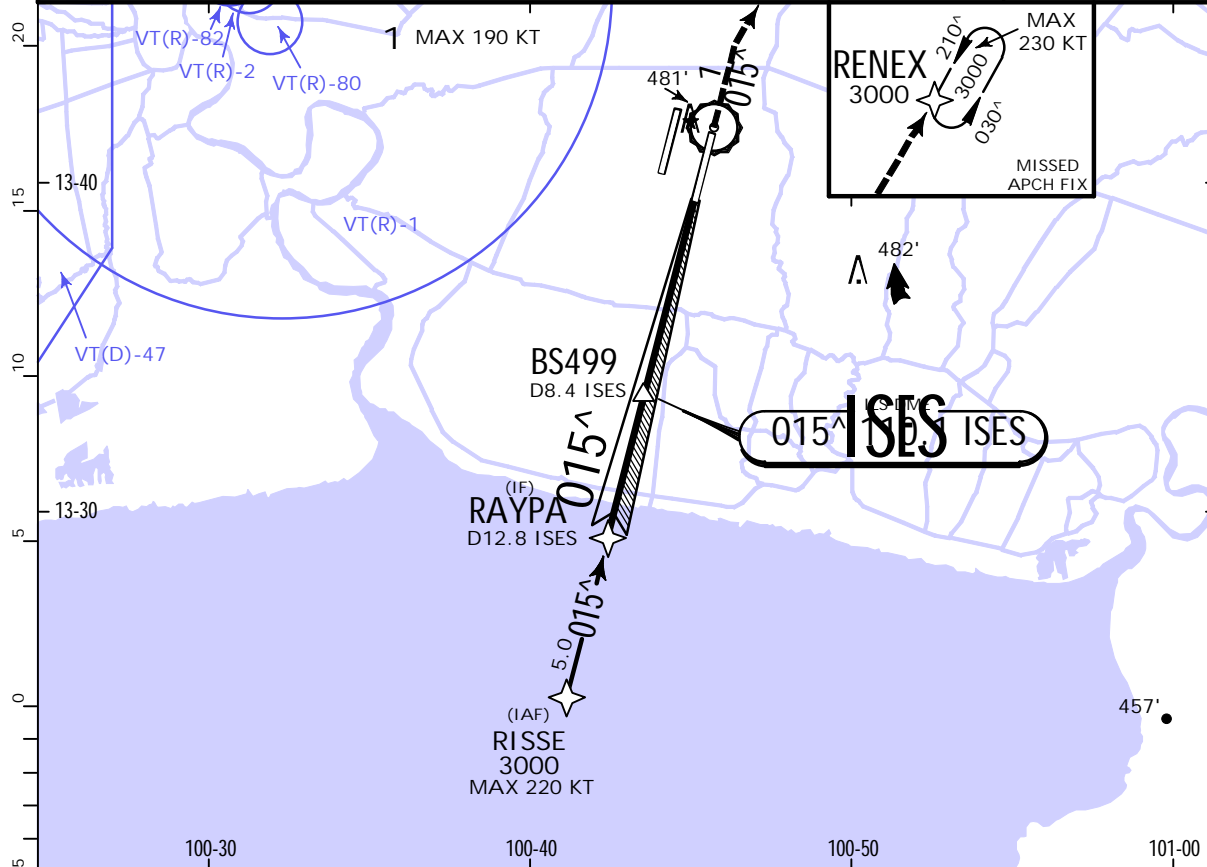
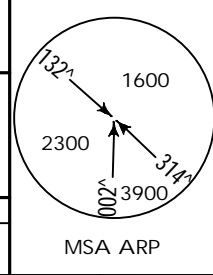

Gnd speed-Kts	70	90	100	120	140	160	ALSIF-II	1000' on 015 [^] track	RT	RENEX
GS	3.00 [^]	372	478	531	637	743				

STRAIGHT-IN LANDING RWY 01R

CAT II ILS
RA 100'
DA(H) 105' (100')

RVR 350m

PANS OPS

VTBS/BKK

SUVARNABHUMI INTL

JEPPESSEN
5 FEB 21 (21-4)

BANGKOK, THAILAND

ILS or LOC Y Rwy 01R

D-ATIS Arrival	SUVARNABHUMI Arrival (R)	BANGKOK Approach (R)			SUVARNABHUMI Tower		Ground		
133.6	121.1 126.3	119.1	120.3	122.35	Rwy 01L/19R	Rwy 01R/19L	West Apron	Main Apron	East Apron
		124.35	125.2	128.95	119.0	118.2	121.95	121.75	121.65

BRIEFING STRIP™

LOC ISES 110.1	Final Apch Crs 015^	ROMAN 2000' (1995')	ILS DA(H) 205' (200')	Apt Elev 5' Rwy 5'
MISSED APCH: Climb STRAIGHT AHEAD to intercept and proceed outbound on SVB VOR R-030 to 3000' and hold at D10.0 SVB or as directed by ATC. If unable to reach 3000' at SVB VOR R-030/D10.0 SVB continue climb in the holding pattern.				
Alt Set: hPa Rwy Elev: 0 hPa Trans level: FL 130 Trans alt: 11000'				
Non-RADAR procedure: Aircraft will be cleared to BKK VOR then transition to ROMAN to carry out the ILS approach.				

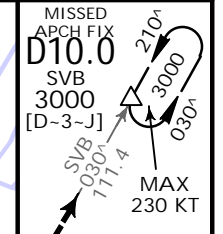
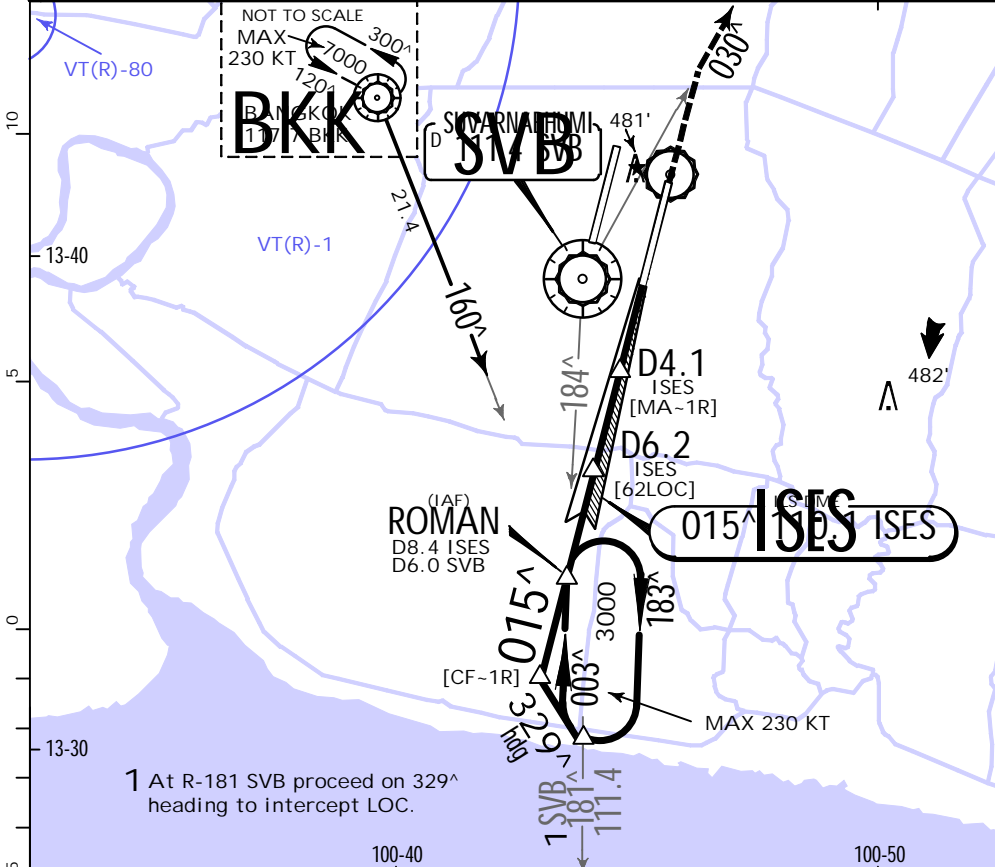
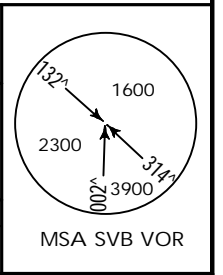

RECOMMENDED ALTITUDES	
LOC (GS out)	
ISES DME	ALTITUDE
ROMAN	2000'
8.0	1870'
7.0	1550'
6.0	1240'
5.0	920'
4.1	650'

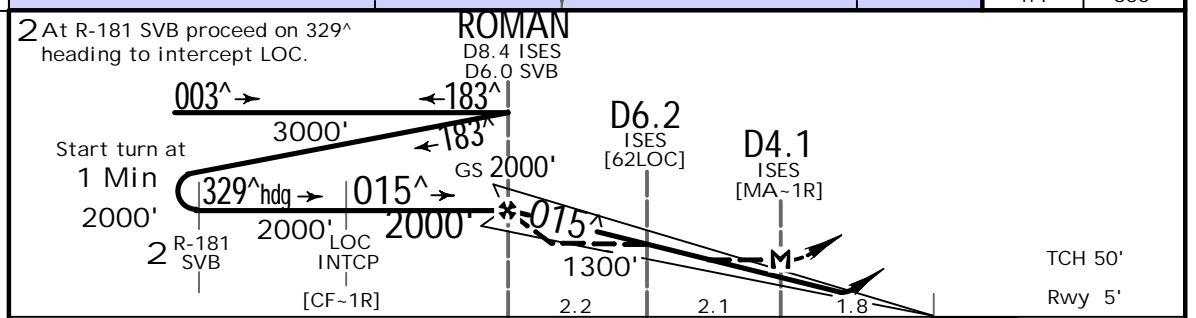

Gnd speed-Kts	70	90	100	120	140	160
ILS GS or LOC Descent Angle	3.00^	372	478	531	637	743
MAP at D4.1 ISES						
FAF to MAP	4.3	3:41	2:52	2:35	2:09	1:51

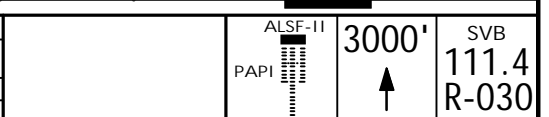

PANS OPS	STRAIGHT-IN LANDING RWY 01R				CIRCLE-TO-LAND	
	ILS 205' (200')		LOC (GS out) 650' (645')		CIRCLE-TO-LAND	
	FULL	TDZ/CL out	ALS out	ALS out	MDA(H)	
A					800' (795') - 3200m	
B	RVR 550m	RVR 720m	1200m	3200m	900' (895') - 4400m	
C	vis 800m	vis 800m			900' (895') - 4800m	
D						

CHANGES: Communications.

VTBS/BKK
SUVARNABHUMI INTL



BANGKOK, THAILAND
ILS Y Rwy 01R CAT II

5 FEB 21 (21-4A)

D-ATIS Arrival	SUVARNABHUMI Arrival (R)	BANGKOK Approach (R)			SUVARNABHUMI Tower		Ground		
133.6	121.1 126.3	119.1	120.3	122.35	Rwy 01L/19R	Rwy 01R/19L	West Apron	Main Apron	East Apron
		124.35	125.2	128.95	119.0	118.2	121.95	121.75	121.65

BRIEFING STRIP

LOC ISES	Final Apch Crs	ROMAN	CAT II ILS	Apt Elev
110.1	015 [^]	2000' (1995')	RA 100'	5'
			DA(H) 105' (100')	Rwy 5'

MISSED APCH: Climb STRAIGHT AHEAD to intercept and proceed outbound on SVB VOR R-030 to 3000' and hold at D10.0 SVB or as directed by ATC. If unable to reach 3000' at SVB VOR R-030/D10.0 SVB continue climb in the holding pattern.

Alt Set: hPa Rwy Elev: 0 hPa Trans level: FL 130 Trans alt: 11000'

1. Special Aircrew and Aircraft Certification required. 2. Non-RADAR procedure: Aircraft will be cleared to BKK VOR then transition to ROMAN to carry out the ILS approach.

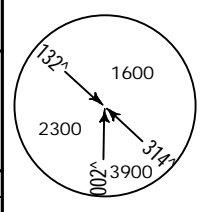

MSA SVB VOR

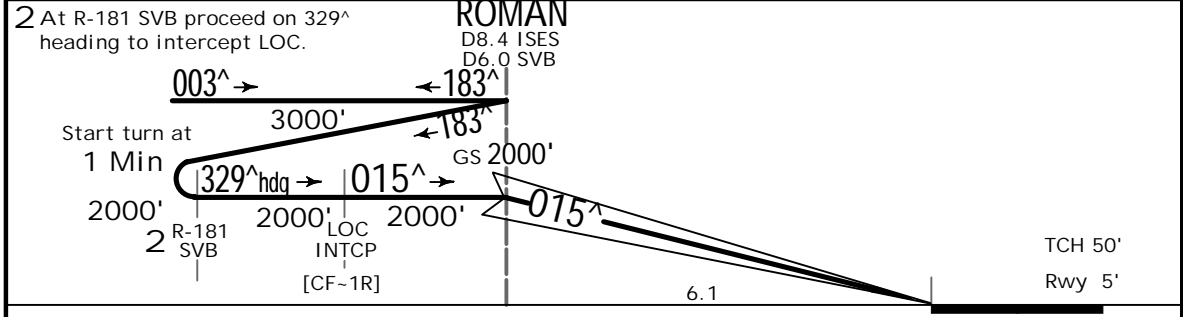
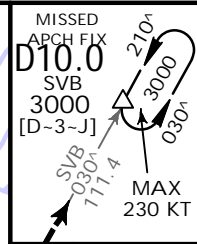
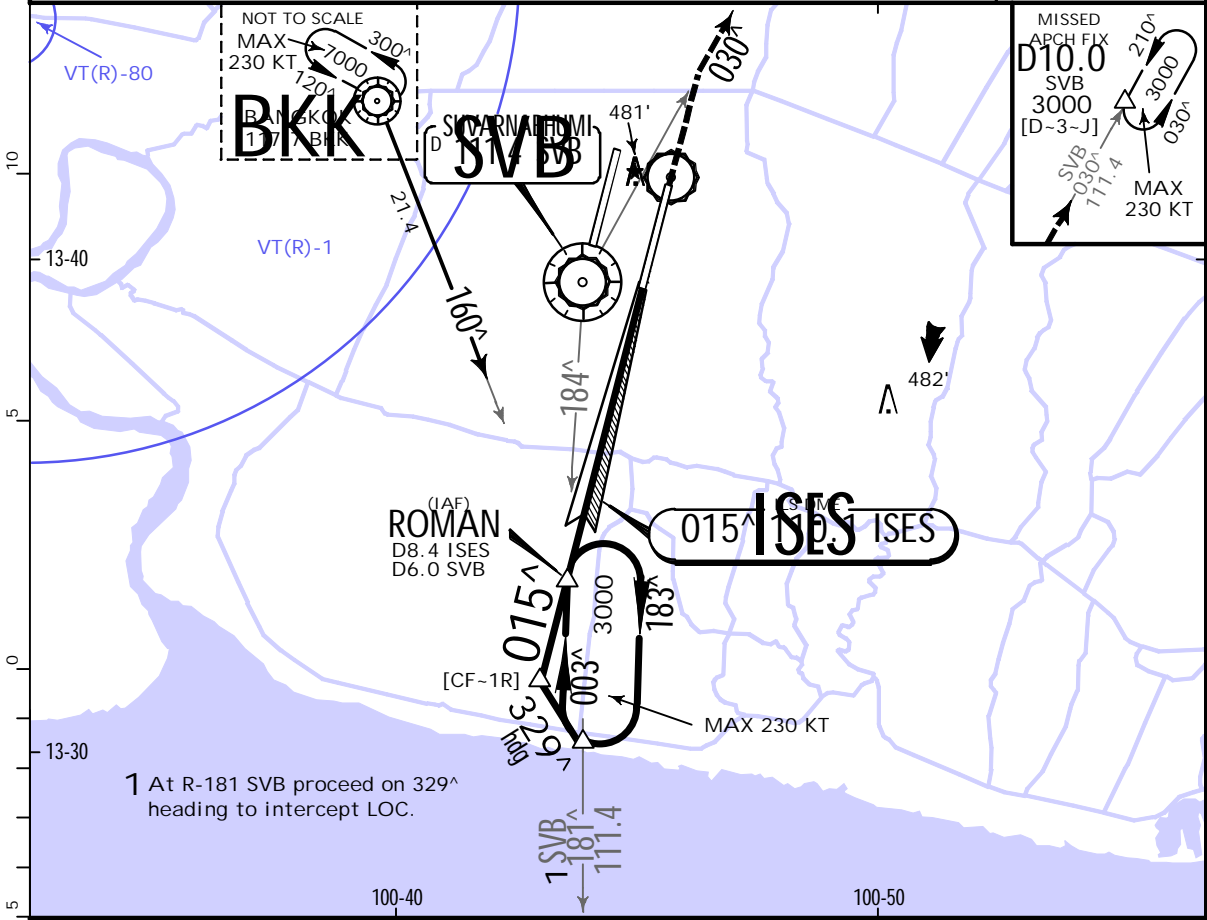

Gnd speed-Kts	70	90	100	120	140	160
GS	3.00 [^]	372	478	531	637	743

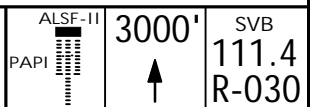

STRAIGHT-IN LANDING RWY 01R
CAT II ILS
RA 100'
DA(H) 105' (100')

RVR 350m

PANS OPS

VTBS/BKK
SUVARNABHUMI INTL



BANGKOK, THAILAND
ILS or LOC Z Rwy 19L

D-ATIS	SUVARNABHUMI Arrival (R)	BANGKOK Approach (R)			SUVARNABHUMI Tower		Ground		
133.6	121.1 126.3	119.1 120.3 122.35	124.35 125.2 128.95	Rwy 01L/19R	Rwy 01R/19L	West Apron	Main Apron	East Apron	
LOC ISEN 110.5		Final Apch Crs 195 [^]	GS BS599 (1995')	ILS DA(H) 205' (200')	Apt Elev 5' Rwy 5'				
MISSED APCH: Climb to 1000' on track 195 [^] , then climbing LEFT turn direct to LASON at 3000' and hold or as directed by ATC. If unable to reach 3000' at LASON, continue climb in the holding pattern. No turn before MAP (for LOC only). Speed restricted to MAX 190 KT until after turn.									
Alt Set: hPa		Rwy Elev: 0 hPa	Trans level: FL 130	Trans alt: 11000'					
RNAV 1 required									
1. GNSS or DME/DME/IRU required. 2. RADAR required. 3. DME required.									

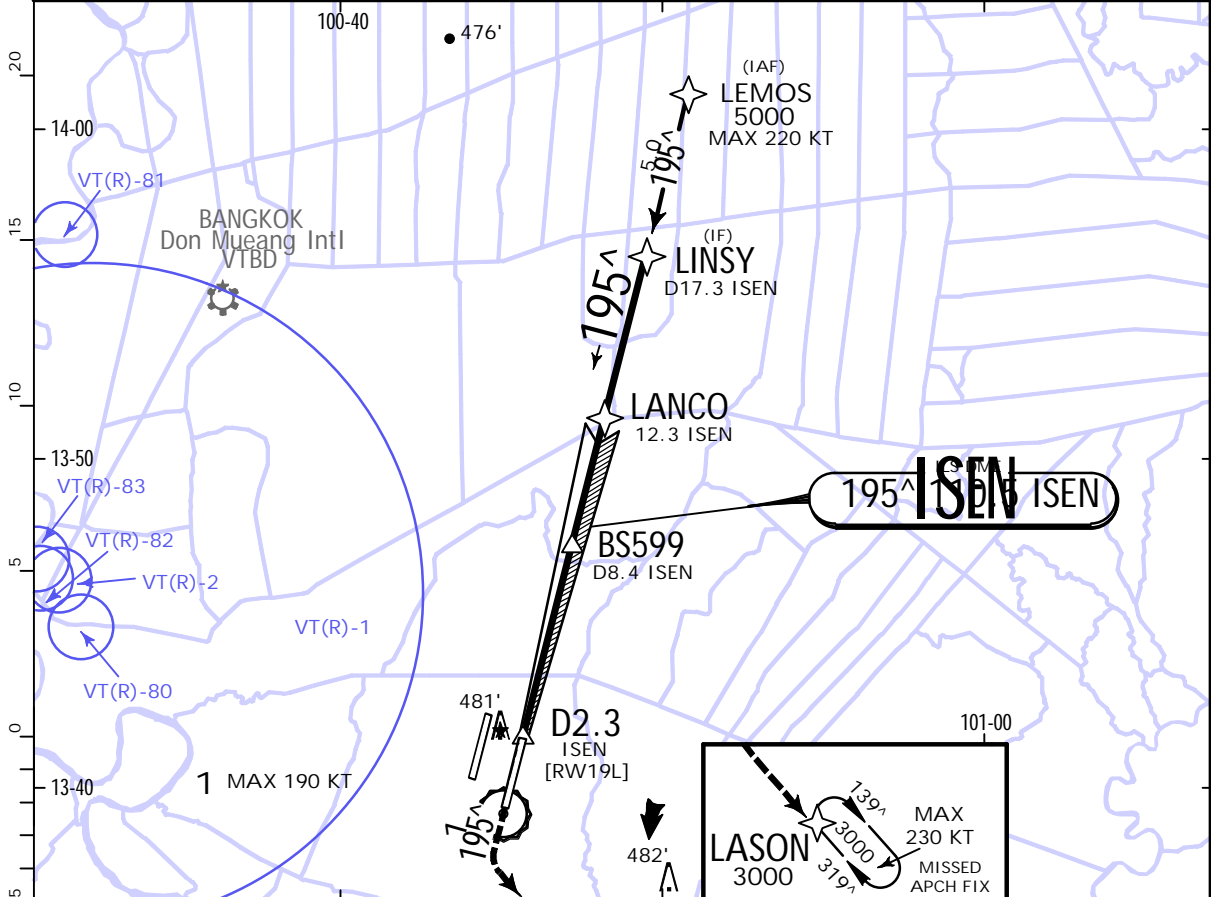

LOC (GS out)	ISEN DME	4.0	5.0	6.0	7.0	8.0	BS599
	ALTITUDE	590'	910'	1225'	1540'	1855'	2000'

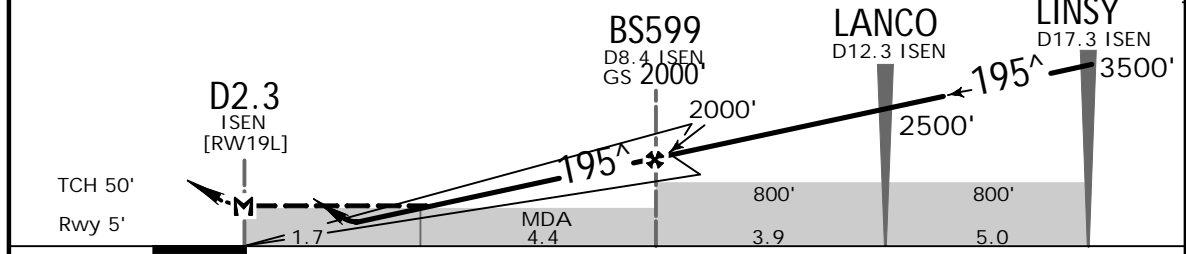

Gnd speed-Kts	70	90	100	120	140	160	ALSF-II PAPI 1000' on 195 [^] track LT D → LASON
GS	3.00 [^]	372	478	531	637	743	
MAP at D2.3 ISEN or FAF to MAP	6.1	5:14	4:04	3:40	3:03	2:37	

STRAIGHT-IN LANDING RWY 19L					CIRCLE-TO-LAND		
ILS DA(H) 205' (200')			LOC (GS out) MDA(H) 590' (585')			Max Kts	MDA(H)
FULL	IDZ or CL out	ALS out	ALS out			100	800' (795') -1600m
A			800m	1600m		135	800' (795') -2000m
B	RVR 550m	RVR 720m	1200m	1600m	2400m	180	900' (895') -4400m
C	VIS 800m	VIS 800m		2000m	2800m	205	900' (895') -4800m
D							

PANS OPS

VTBS/BKK
SUVARNABHUMI INTL



BANGKOK, THAILAND
ILS Z Rwy 19L CAT II

5 FEB 21 (21-5A)

D-ATIS	SUVARNABHUMI Arrival (R)	BANGKOK Approach (R)	SUVARNABHUMI Tower Rwy 01L/19R Rwy 01R/19L	Ground West Apron Main Apron East Apron
133.6	121.1 126.3	119.1 120.3 122.35 124.35 125.2 128.95	119.0 118.2	121.95 121.75 121.65

BRIEFING STRIP™

LOC ISEN 110.5	Final Apch Crs 195[^]	GS BS599 2000' (1995')	CAT II ILS RA 100 DA(H) 105' (100')	Apt Elev 5' Rwy 5'
--------------------------	--	-------------------------------------	--	-----------------------

MISSED APCH: Climb to 1000' on track 195[^], then climbing LEFT turn direct to LASON at 3000' and hold or as directed by ATC. If unable to reach 3000' at LASON, continue climb in the holding pattern. Speed restricted to MAX 190 KT until after turn.

RNAV 1 required Alt Set: hPa Rwy Elev: 0 hPa Trans level: FL 130 Trans alt: 11000'

1. Special Aircrew and Aircraft Certification required. 2. GNSS or DME/DME/IRU required. 3. RADAR required. 4. DME required.

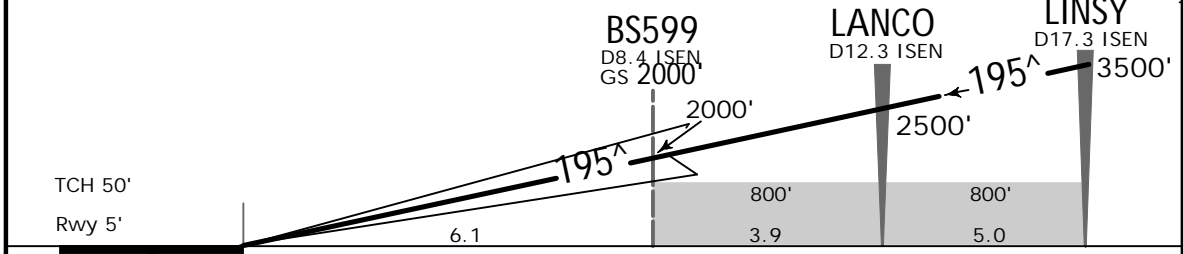
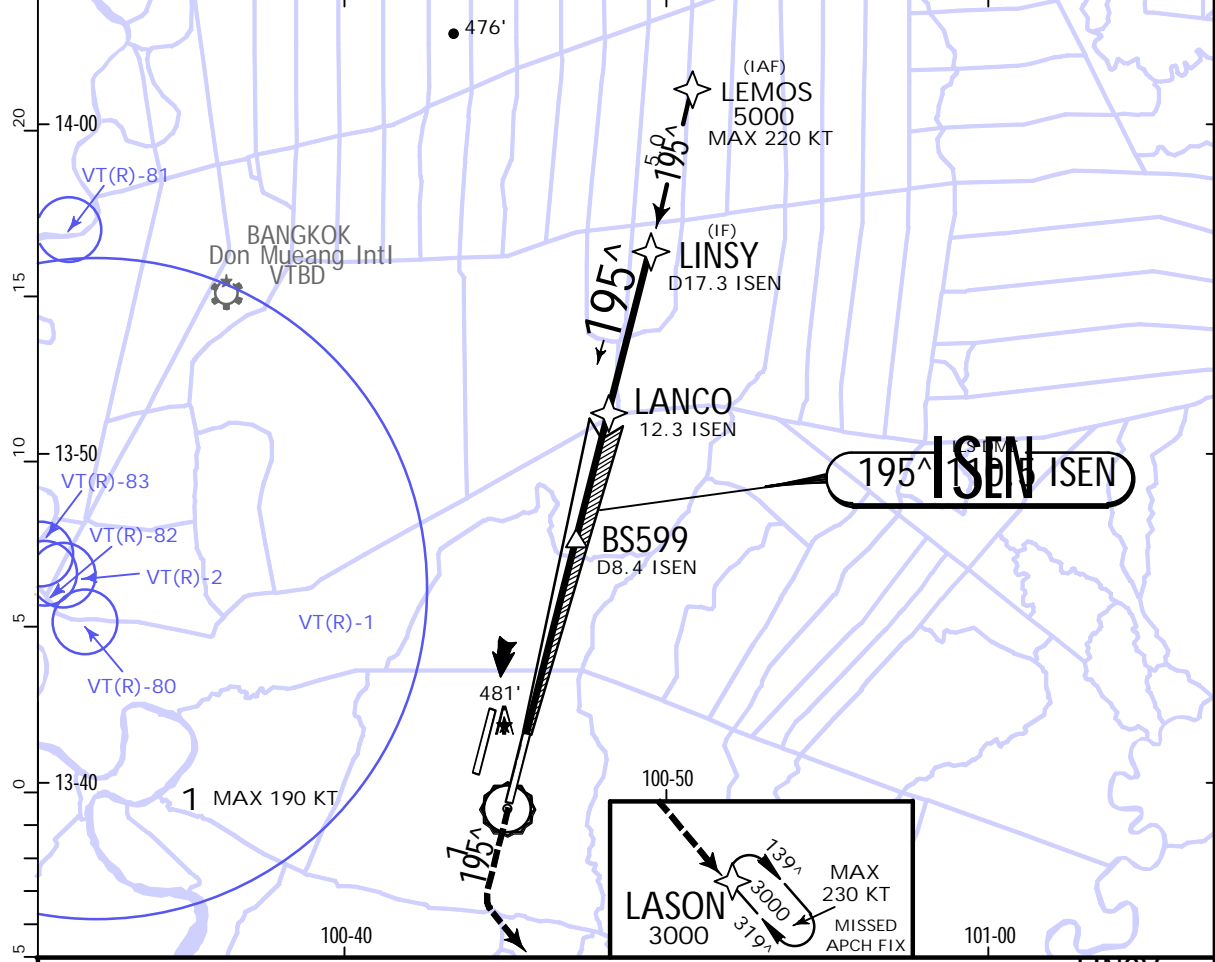
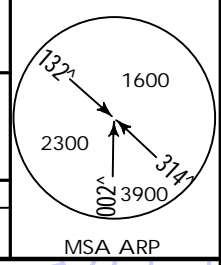

Gnd speed-Kts	70	90	100	120	140	160
GS	3.00 [^]	372	478	531	637	743

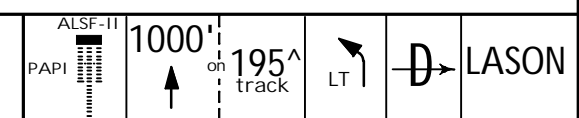

STRAIGHT-IN LANDING RWY 19L
CAT II ILS
RA 100'
DA(H) 105' (100')

RVR 350m

PANS OPS

VTBS/BKK
SUVARNABHUMI INTL



BANGKOK, THAILAND
ILS or LOC Y Rwy 19L

D-ATIS	SUVARNABHUMI Arrival (R)	BANGKOK Approach (R)	SUVARNABHUMI Tower	Ground
133.6	126.3 121.1	119.1 120.3 122.35 124.35 125.2 128.95	Rwy 01R/19L Rwy 01L/19R 118.2 119.0	West Apron Main Apron East Apron 121.95 121.75 121.65
LOC ISEN 110.5	Final Apch Crs 195[^]	GS LEMON 2000 (1995')	ILS DA(H) 205 (200')	Apt Elev 5' Rwy 5'
<p>MISSED APCH: Climb straight ahead to intercept and proceed outbound on SVB VOR R-139 to 3000' and hold at D8.0 SVB, or as directed by ATC. If unable to reach 3000' at SVB VOR R-139/D8.0 SVB, continue climb in the holding pattern.</p>				<p>MSA SVB VOR</p>
<p>Alt Set: hPa Rwy Elev: 0 hPa Trans level: FL 130 Trans alt: 11000'</p>				
<p>1. Non-RADAR procedure: Aircraft will be cleared to BKK VOR then transition to LEMON to carry out the ILS approach.</p>				

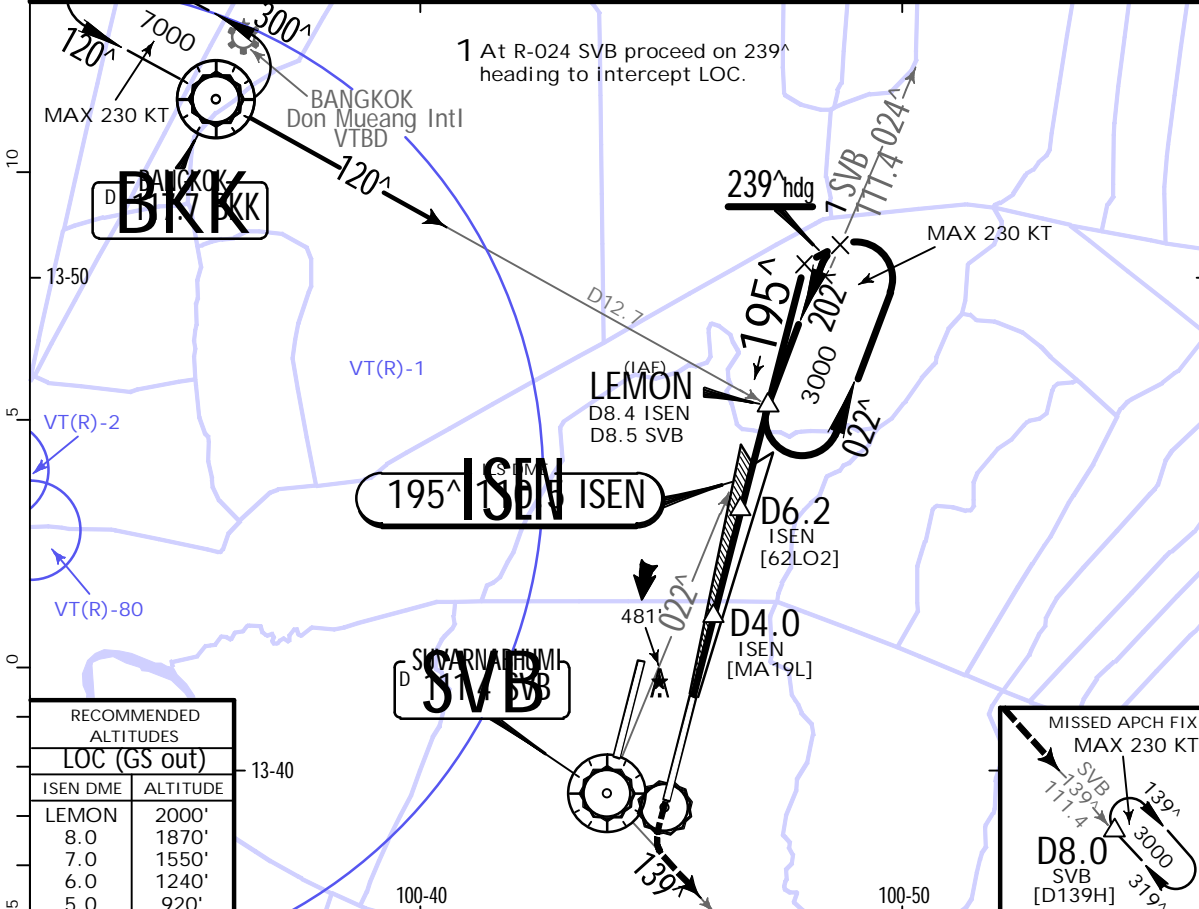

RECOMMENDED ALTITUDES	
LOC (GS out)	
ISEN DME	ALTITUDE
LEMON	2000'
8.0	1870'
7.0	1550'
6.0	1240'
5.0	920'

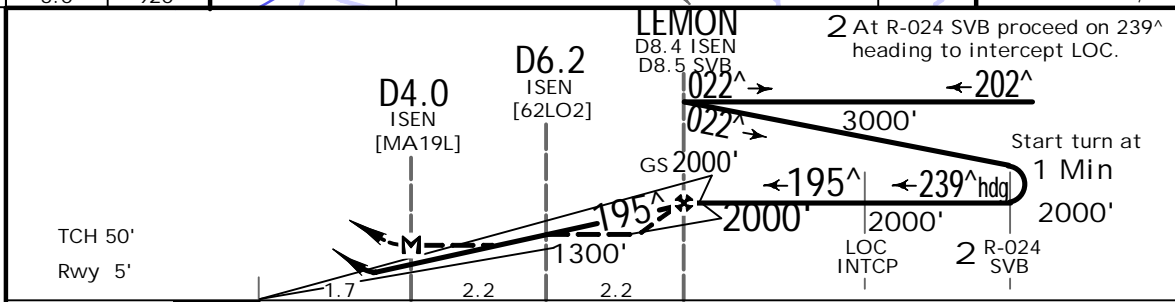
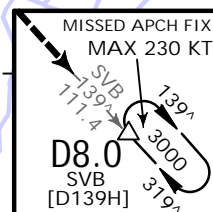

Gnd speed-Kts	70	90	100	120	140	160	
ILS GS or	3.00 [^]	372	478	531	637	743	
LOC Descent Angle							
MAP at D4.0 ISEN or LEMON to MAP	4.4	3:46	2:56	2:38	2:12	1:53	<p>3000' SVB on 111.4 R-139</p>

STRAIGHT-IN LANDING RWY 19L				CIRCLE-TO-LAND			
ILS DA(H) 205 (200')		LOC (GS out) MDA(H) 590 (585')		Max Kts		MDA(H)	
FULL	IDZ or CL out	ALS out	ALS out	100	800' (795') -3200m		
A				135			
B	RVR 550m	RVR 720m	1200m	180	900' (895') -4400m		
C	VIS 800m	VIS 800m	2400m	205	900' (895') -4800m		
D			3200m				

PANS OPS

VTBS/BKK
SUVARNABHUMI INTL



BANGKOK, THAILAND
ILS Y Rwy 19L CAT II

5 FEB 21 (21-6A)

D-ATIS	SUVARNABHUMI Arrival (R)	BANGKOK Approach (R)			SUVARNABHUMI Tower		Ground		
133.6	126.3 121.1	119.1 120.3 122.35	124.35 125.2 128.95	118.2	119.0	121.95	121.75	121.65	
				Rwy 01R/19L	Rwy 01L/19R	West Apron	Main Apron	East Apron	

BRIEFING STRIP™

LOC ISEN 110.5	Final Apch Crs 195^	GS LEMON 2000' (1995')	CAT II ILS RA 100' DA(H) 105'(100')	Apt Elev 5' Rwy 5'
--------------------------	-------------------------------	----------------------------------	--	-----------------------

MISSED APCH: Climb straight ahead to intercept and proceed outbound on SVB VOR R-139 to 3000' and hold at D8.0 SVB, or as directed by ATC. If unable to reach 3000' at SVB VOR R-139/D8.0 SVB, continue climb in the holding pattern.

Alt Set: hPa Rwy Elev: 0 hPa Trans level: FL 130 Trans alt: 11000'

1. Special Aircrew and Aircraft Certification required. 2. Non-RADAR procedure: Aircraft will be cleared to BKK VOR then transition to LEMON to carry out the ILS approach.

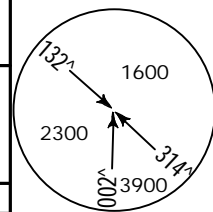

MSA SVB VOR

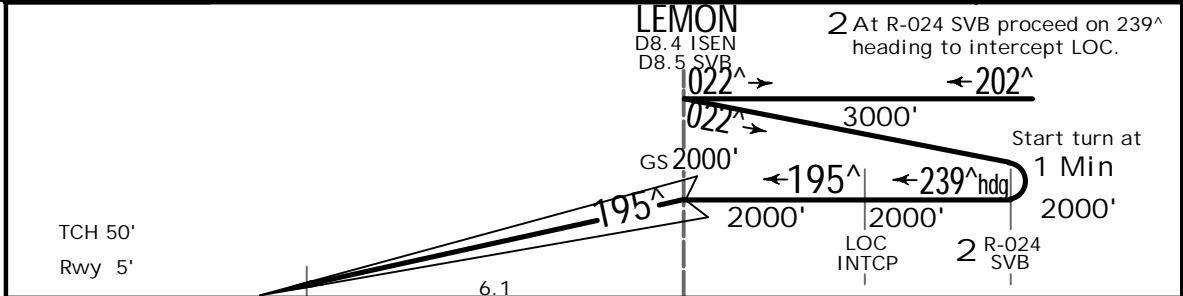
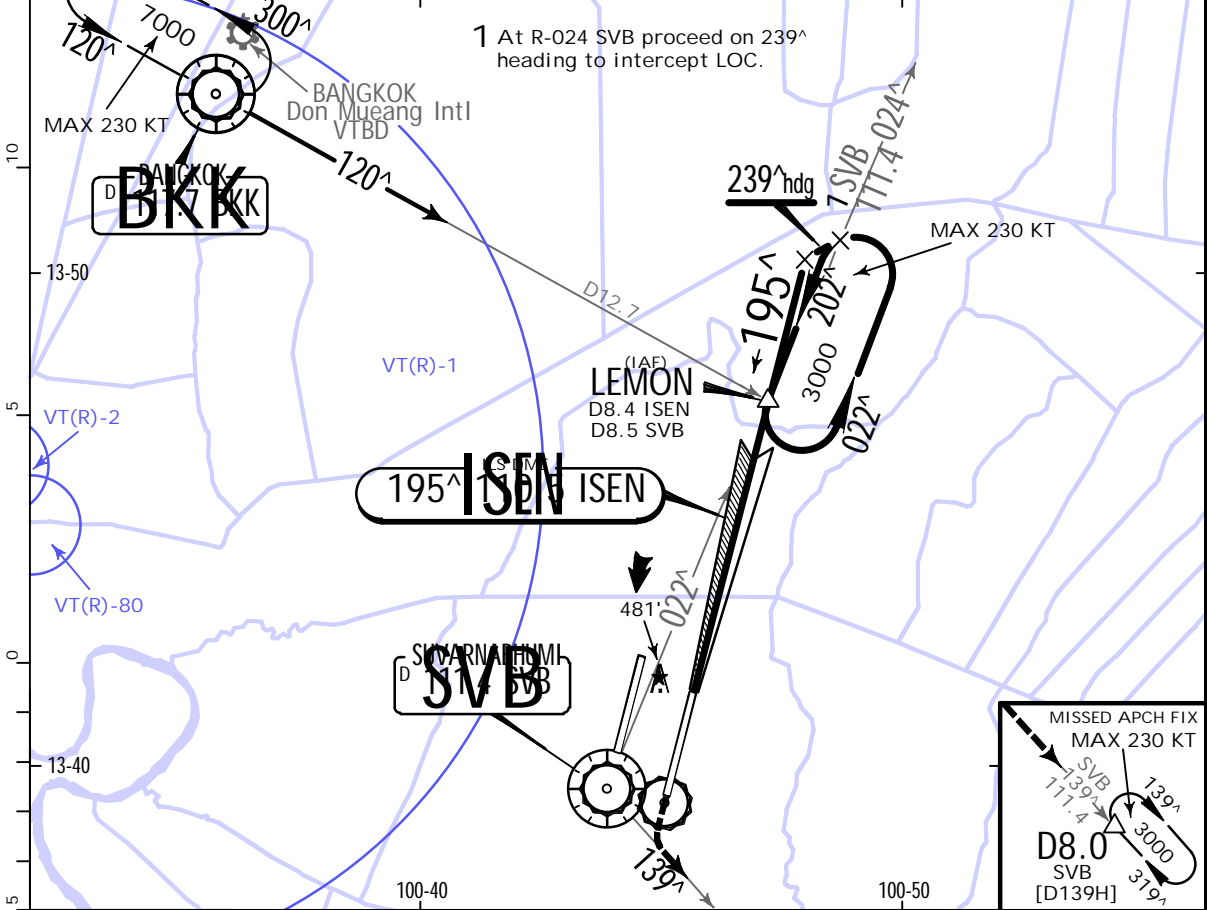

Gnd speed-Kts	70	90	100	120	140	160	ALSF-II PAPI	3000' SVB on 111.4 R-139
GS	3.00^	372	478	531	637	849		

STRAIGHT-IN LANDING RWY 19L
CAT II ILS
RA 100'
DA(H) 105'(100')

PANS OPS

RVR 350m

VTBS/BKK
SUVARNABHUMI INTL



BANGKOK, THAILAND
ILS OR LOC Z Rwy 19R

5 FEB 21 **(21-7)**

D-ATIS 133.6	SUVARNABHUMI Arrival (R) 121.1 126.3	BANGKOK Approach (R) 119.1 120.3 122.35 124.35 125.2 128.95			SUVARNABHUMI Tower Rwy 01L/19R Rwy 01R/19L 119.0 118.2		Ground West Apron Main Apron East Apron 121.95 121.75 121.65				
LOC ISWN 109.5	Final Apch Crs 195^	GS BS588 2000' (1995')	ILS DA(H) 205' (200')	Apt Elev 5' Rwy 5'			<p>MSA ARP</p>				
<p>MISSED APCH: Climb to 1000' on track 195^, then climbing RIGHT turn direct to RIPSO at 3000' and hold or as directed by ATC. If unable to reach 3000' at RIPSO, continue climb in the holding pattern. No turn before MAP (for LOC only). Speed restricted to MAX 190 KT until after turn.</p>											
Alt Set: hPa			Rwy Elev: 0 hPa		Trans level: FL 130					Trans alt: 11000'	
RNAV 1 Required			1. GNSS or DME/DME/IRU required. 2. Radar required. 3. DME required.								

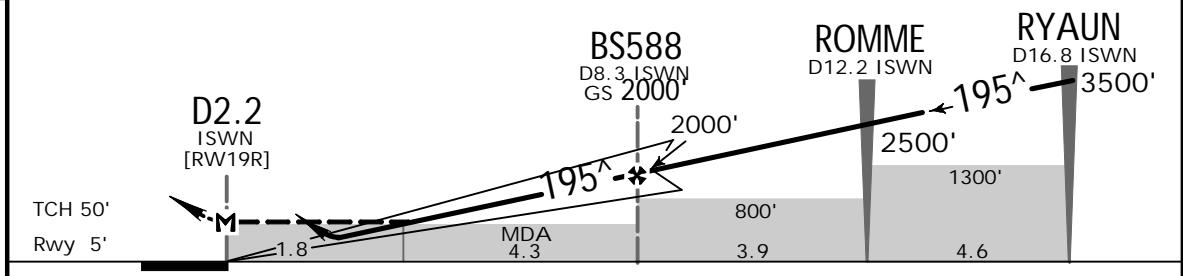
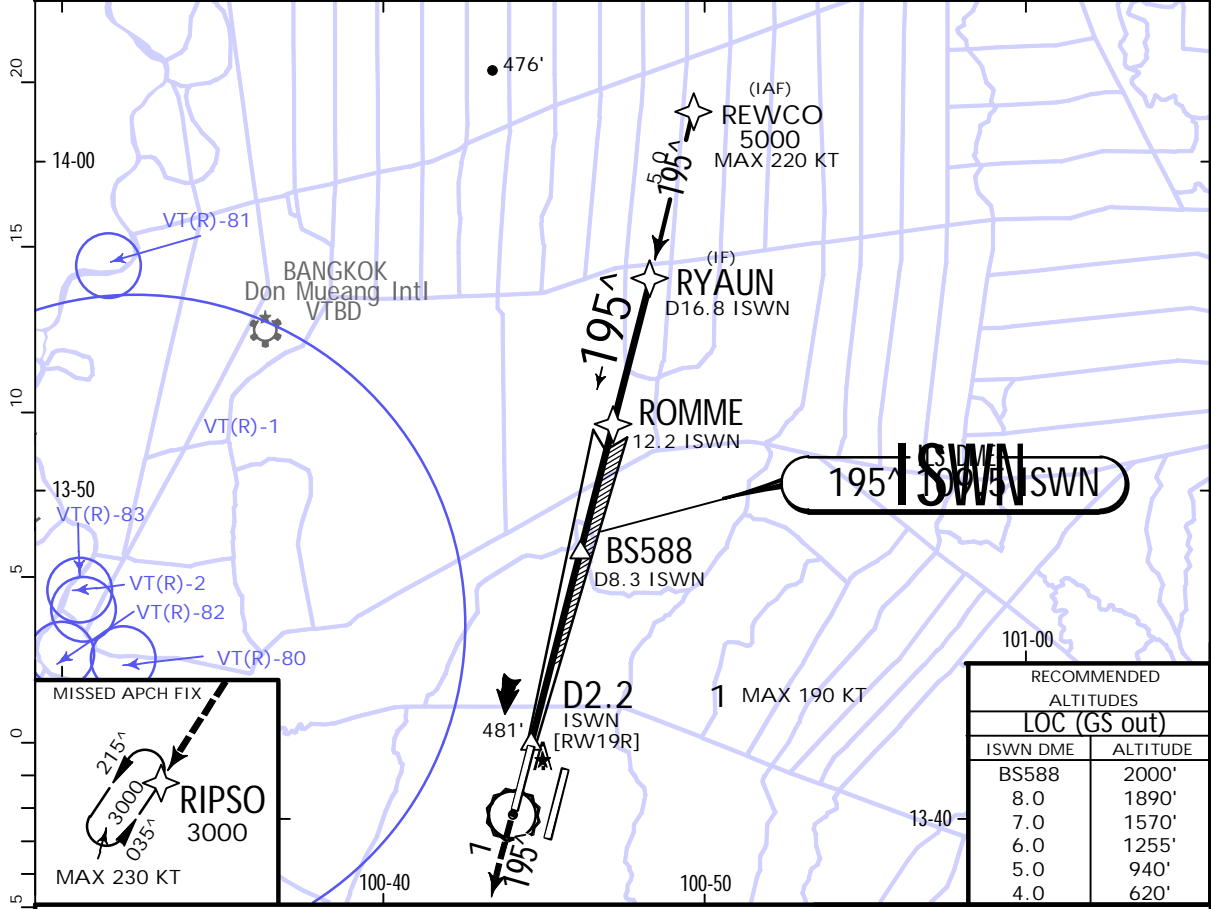

Gnd speed-Kts	70	90	100	120	140	160
GS 3.00^	372	478	531	637	743	849
MAP at D2.2 ISWN or						
FAF to MAP	6.1	5:14	4:04	3:40	3:03	2:37

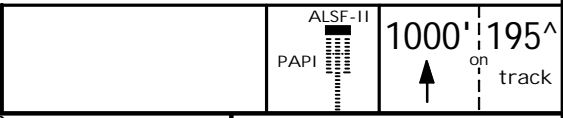

PANS OPS	STRAIGHT-IN LANDING RWY 19R				CIRCLE-TO-LAND	
	ILS DA(H) 205' (200')		LOC (GS out) MDA(H) 620' (615')		Max Kts	MDA(H)
	FULL	IDZ or CL out	ALS out	ALS out		
A					100	800' (795') -1600m
B				800m	135	800' (795') -2000m
C	RVR 550m VIS 800m	RVR 720m VIS 800m	1200m	1600m	180	900' (895') -4400m
D				2000m	205	900' (895') -4800m

CHANGES: Communications.

VTBS/BKK
SUVARNABHUMI INTL

JEPPESSEN
5 FEB 21 (21-7A)

BANGKOK, THAILAND
ILS Z Rwy 19R CAT II

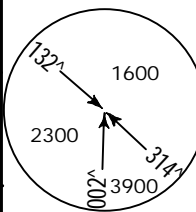
D-ATIS 133.6	SUVARNABHUMI Arrival (R) 121.1 126.3	BANGKOK Approach (R) 119.1 120.3 122.35 124.35 125.2 128.95			SUVARNABHUMI Tower Rwy 01L/19R Rwy 01R/19L 119.0 118.2		Ground West Apron Main Apron East Apron 121.95 121.75 121.65			
LOC ISWN 109.5	Final Apch Crs 195 [^]	GS 2000' (1995')	CAT II ILS RA 100' DA(H) 105' (100)		Apt Elev 5' Rwy 5'		 <p>MSA ARP</p>			
<p>MISSED APCH: Climb to 1000' on track 195[^], then climbing RIGHT turn direct to RIPSO at 3000' and hold or as directed by ATC. If unable to reach 3000' at RIPSO, continue climb in the holding pattern. Speed restricted to MAX 190 KT until after turn.</p>										
<p>RNAV 1 Required Alt Set: hPa Rwy Elev: 0 hPa Trans level: FL 130 Trans alt: 11000'</p> <p>1. Special Aircrew and Aircraft Certification required. 2. GNSS or DME/DME/IRU required. 2. Radar required. 3. DME required.</p>										

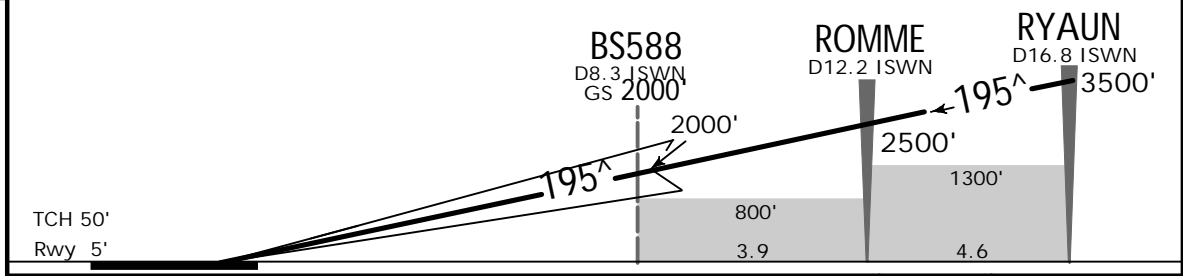
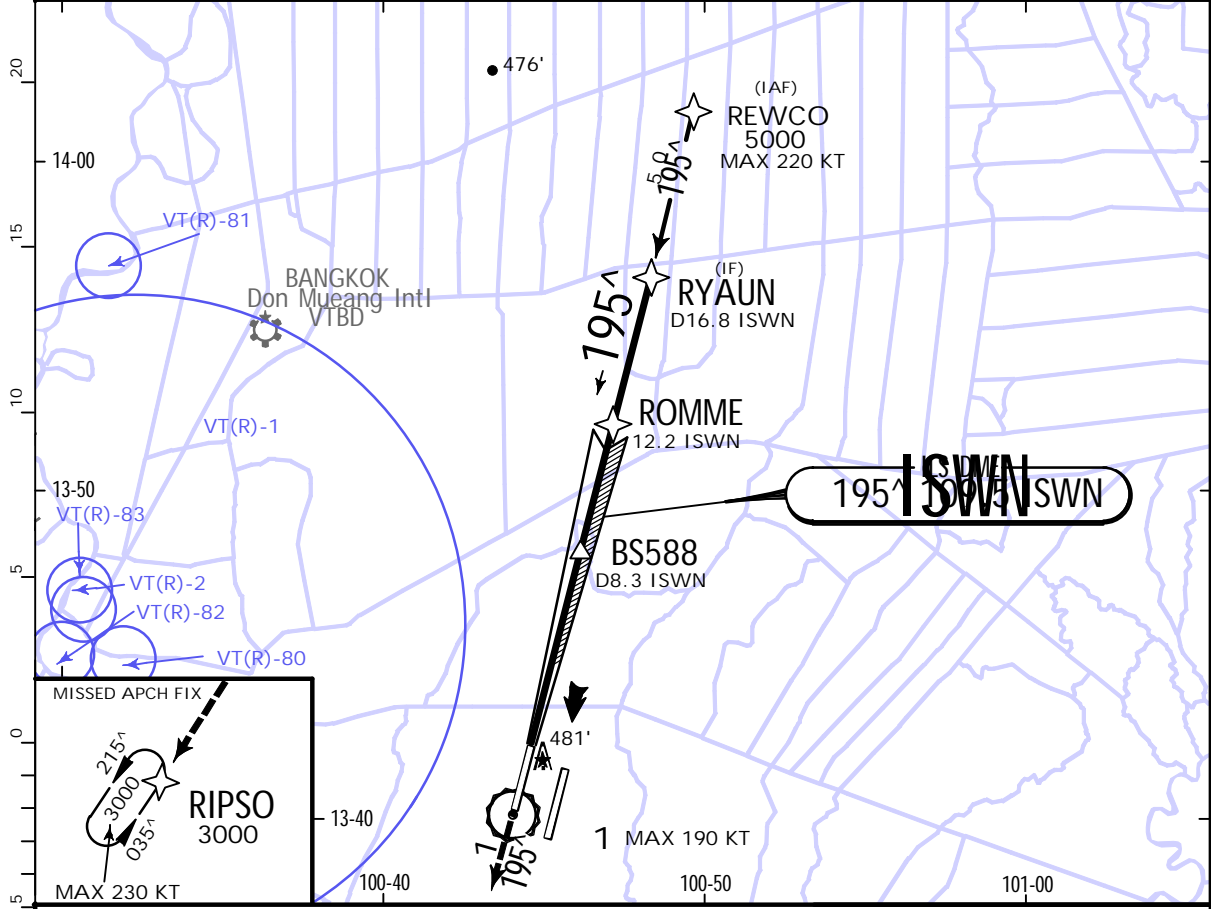

Gnd speed-Kts	70	90	100	120	140	160	
GS	3.00 [^]	372	478	531	637	743	849

ALSIF-II
PAPI
1000' | 195[^]
↑ on track

STRAIGHT-IN LANDING RWY 19R
CAT II ILS
RA 100'
DA(H) 105' (100')

PANS OPS
RVR 350m

VTBS/BKK
SUVARNABHUMI INTL



5 FEB 21 (21-8)

BANGKOK, THAILAND
ILS or LOC Y Rwy 19R

D-ATIS 133.6	SUVARNABHUMI Arrival (R) 126.3 121.1	BANGKOK Approach (R) 119.1 120.3 122.35 124.35 125.2 128.95			SUVARNABHUMI Tower Rwy 01L/19R 119.0 Rwy 01R/19L 118.2		Ground West Apron 121.95 Main Apron 121.75 East Apron 121.65			
LOC ISWN 109.5	Final Apch Crs 195 [^]	GS ROBBY 2000' (1995')	ILS DA(H) 205' (200')	Apt Elev 5' Rwy 5'		<p>MSA SVB VOR</p>				
<p>MISSED APCH: Climb straight ahead to SVB VOR, turn RIGHT on SVB VOR R-215 to 3000' and hold at D7.0 SVB, or as directed by ATC. If unable to reach 3000' at SVB VOR R-215/D7.0 SVB, continue climb in the holding pattern.</p>										
<p>Alt Set: hPa Rwy Elev: 0 hPa Trans level: FL 130 Trans alt: 11000'</p> <p>1. Non-RADAR procedure: Aircraft will be cleared to BKK VOR then transition to ROBBY to carry out the ILS approach.</p>										

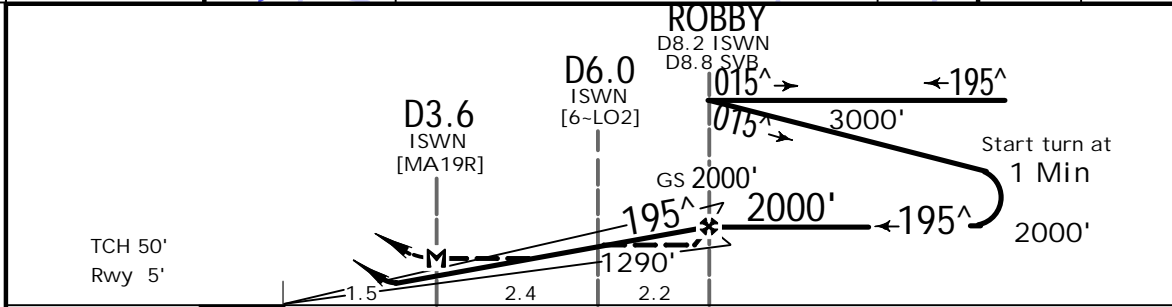
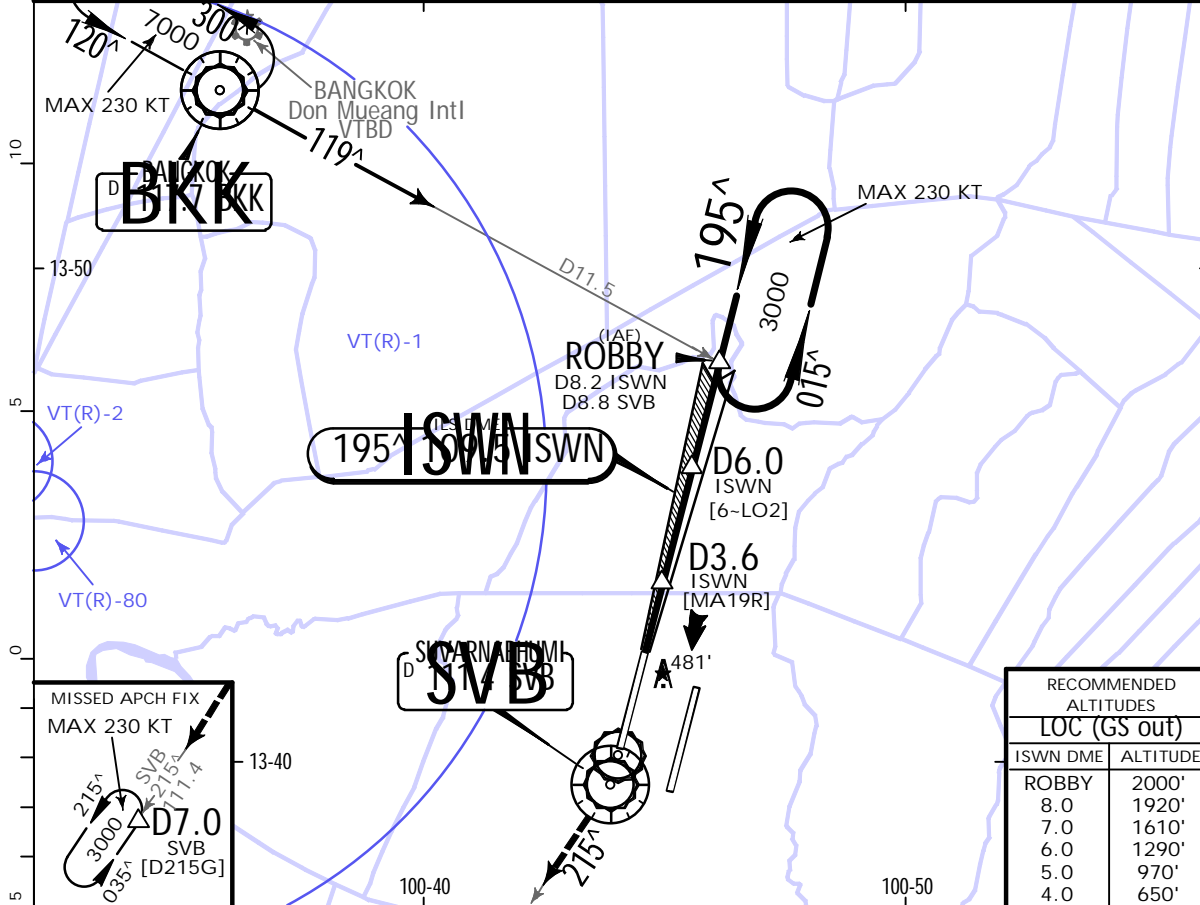

Gnd speed-Kts	70	90	100	120	140	160		SVB 111.4
ILS GS or	3.00 [^]	372	478	531	637	849		
LOC Descent Angle	4.6	3:57	3:04	2:46	2:18	1:58		
MAP at D3.6 ISWN or ROBBY to MAP	4.6	3:57	3:04	2:46	2:18	1:58	1:43	

STRAIGHT-IN LANDING RWY 19R					CIRCLE-TO-LAND			
FULL ILS DA(H) 205' (200')		LOC (GS out) MDA(H) 620' (615')			Max Kts			
ALS out		ALS out			MDA(H)			
A	RVR 550m	RVR 720m	1200m	2000m	2800m	800' (795') -2800m		
B						135		
C	vis 800m	vis 800m	1200m	2000m	2800m	180 900' (895') -4400m		
D						205 900' (895') -4800m		

VTBS/BKK
SUVARNABHUMI INTL



BANGKOK, THAILAND
ILS Y Rwy 19R CAT II

5 FEB 21

(21-8A)

D-ATIS	SUVARNABHUMI Arrival (R)	BANGKOK Approach (R)			SUVARNABHUMI Tower		Ground		
	133.6	126.3 121.1	119.1 120.3 122.35	124.35 125.2 128.95	119.0	118.2	121.95	121.75	121.65
LOC ISWN	Final Apch Crs	GS ROBBY	CAT II ILS RA 100'		Apt Elev 5'				
	109.5	195^	2000' (1995')	DA(H) 105'(100')	Rwy 5'				
<p>MISSED APCH: Climb straight ahead to SVB VOR, turn RIGHT on SVB VOR R-215 to 3000' and hold at D7.0 SVB, or as directed by ATC. If unable to reach 3000' at SVB VOR R-215/D7.0 SVB, continue climb in the holding pattern.</p>									
<p>Alt Set: hPa Rwy Elev: 0 hPa Trans level: FL 130 Trans alt: 11000'</p>									
<p>1. Special Aircrew and Aircraft Certification required. 2. Non-RADAR procedure: Aircraft will be cleared to BKK VOR then transition to ROBBY to carry out the ILS approach.</p>									

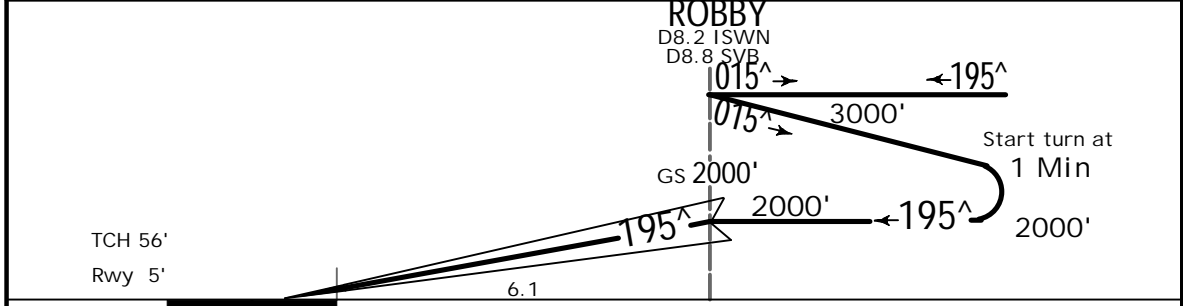
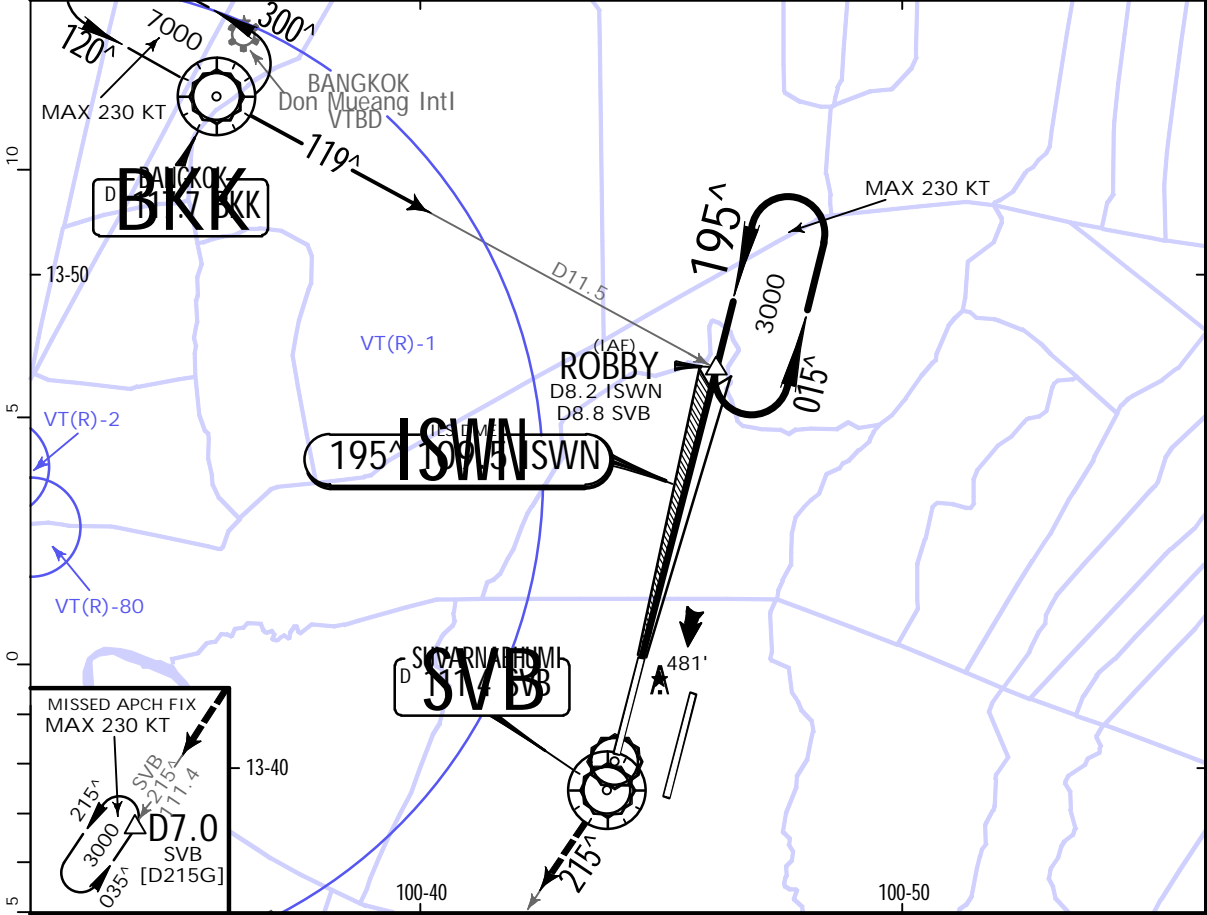

Gnd speed-Kts	70	90	100	120	140	160	ALSIF-II	SVB
GS	3.00^	372	478	531	637	743		

STRAIGHT-IN LANDING RWY 19R
CAT II ILS
RA 100'
DA(H) 105'(100')

PANS OPS
RVR 350m

VTBS/BKK
SUVARNABHUMI INTL

JEPPESEN
1 OCT 21 (22-1) Eff. 7.Oct.

BANGKOK, THAILAND
RNP Rwy 01L

D-ATIS Arrival	SUVARNABHUMI Arrival (R)	BANGKOK Approach (R)				SUVARNABHUMI Tower		Ground		
		119.1	120.3	122.35	119.0	Rwy 01L/19R	Rwy 01R/19L	West Apron	Main Apron	East Apron
133.6	126.3 121.1	124.35	125.2	128.95	119.0	118.2	121.95	121.75	121.65	
RNAV	Final Apch Crs	BS488		LNAV/VNAV DA(H)	Apt Elev 5'					
	015^	2000' (1995')		400' (395')	Rwy 5'					
MISSED APCH: Climb to 3000' on course 015^ to LAINO and hold, or as directed by ATC. If unable to reach 3000' at LAINO, continue climb in the holding pattern. No turn before MAP. Speed restricted to MAX 210 KT.										
RNP Apch	Alt Set: hPa	Rwy Elev: 0 hPa	Trans level: FL 130		Trans alt: 11000'					
Baro-VNAV not authorized below 15^C.										



NM to NEXT WPT	BS488	6.0	5.0	4.0	3.0	2.0	1.7
ALTITUDE	2000'	1950'	1635'	1320'	1005'	690'	600'

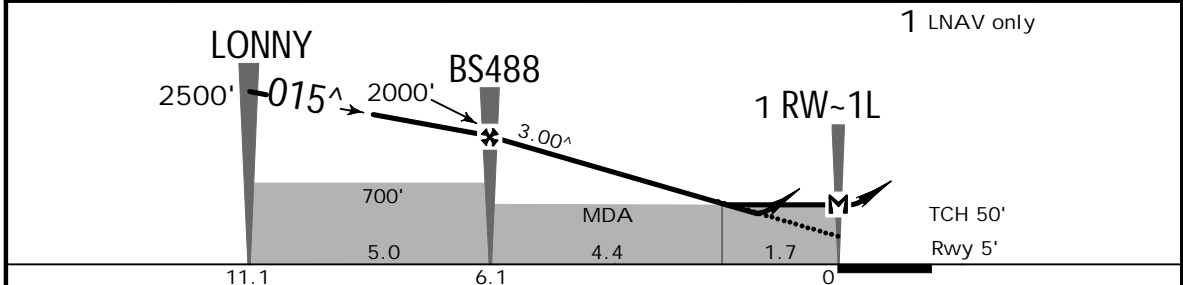

Gnd speed-Kts	70	90	100	120	140	160	ALSF-II PAPI 3000' on 015^ LAINO	
Descent Angle	3.00^	372	478	531	637	743		849
MAP at RW-1L								

STRAIGHT-IN LANDING RWY 01L				CIRCLE-TO-LAND			
LNAV/VNAV DA(H) 400' (395')		LNAV MDA(H) 600' (595')					
ALS out		ALS out		Max Kts		MDA(H)	
A				100	800' (795')-1600m		
B	800m	1600m		135	800' (795')-2000m		
C			1600m	180	900' (895')-4400m		
D	1600m	2000m	2000m	205	900' (895')-4800m		

VTBS/BKK

SUVARNABHUMI INTL

JEPPESEN
1 OCT 21 (22-2) Eff. 7.Oct.

BANGKOK, THAILAND

RNP Rwy 01R

D-ATIS Arrival	SUVARNABHUMI Arrival (R)	BANGKOK Approach (R)			SUVARNABHUMI Tower		Ground		
		119.1	120.3	122.35	Rwy 01L/19R	Rwy 01R/19L	West Apron	Main Apron	East Apron
133.6	126.3 121.1	124.35	125.2	128.95	119.0	118.2	121.95	121.75	121.65
RNAV	Final Apch Crs	BS499	LNNAV/VNAV DA(H)	Apt Elev 5'					
015^	2000' (1995')	540' (535')	Rwy 5'						
<p>MISSED APCH: Climb to 1500' on track 015^, then climbing turn RIGHT direct to RENEX at 3000' and hold or as directed by ATC. If unable to reach 3000' at RENEX, continue climb in the holding pattern. No turn before MAP. Speed restricted to MAX 210 KT until after turn.</p>									
RNP Apch	Alt Set: hPa	Rwy Elev: 0 hPa	Trans level: FL 130	Trans alt: 11000'	MSA ARP				
Baro-VNAV not authorized below 15°C.									

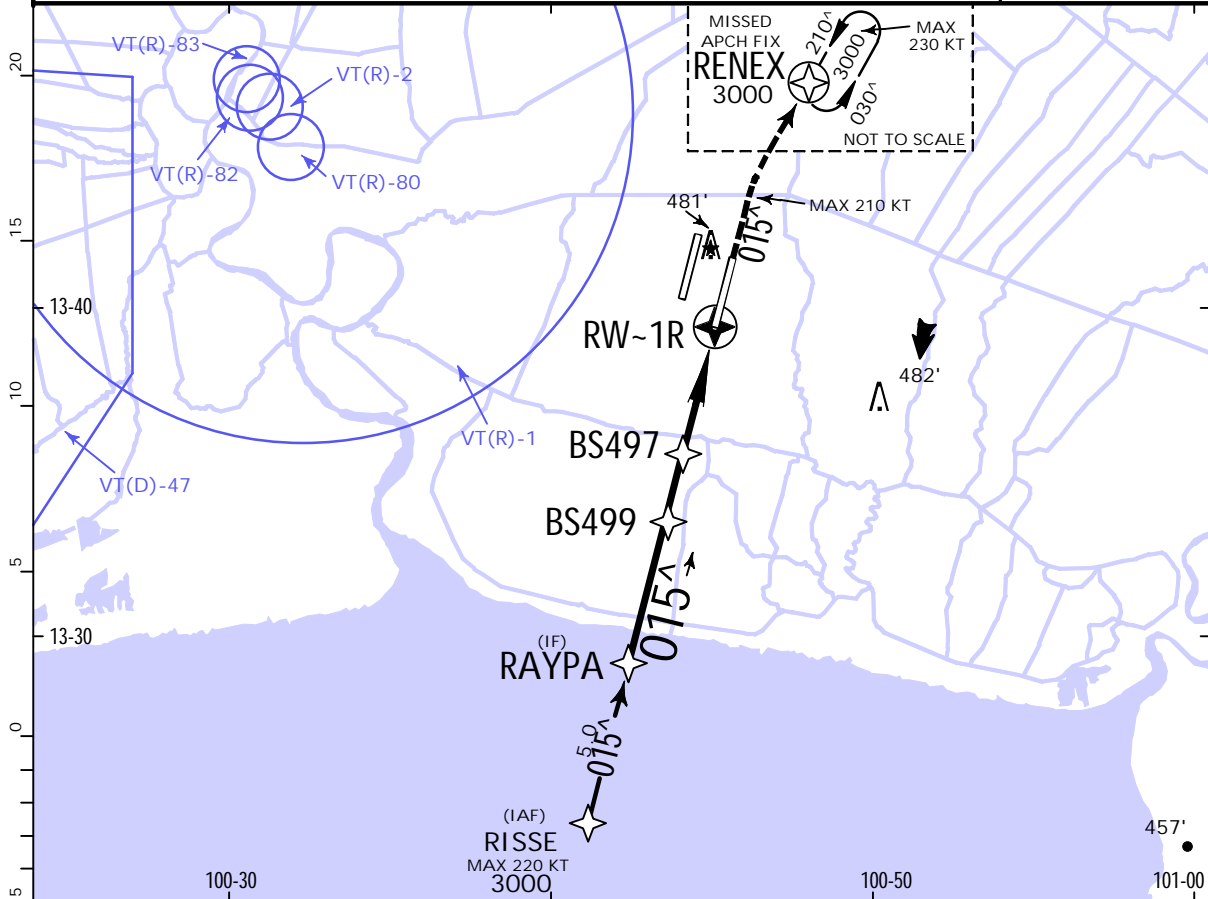

NM to NEXT WPT	BS499	6.0	5.0	4.0	3.0	2.0	1.7
ALTITUDE	2000'	1950'	1635'	1320'	1005'	690'	600'

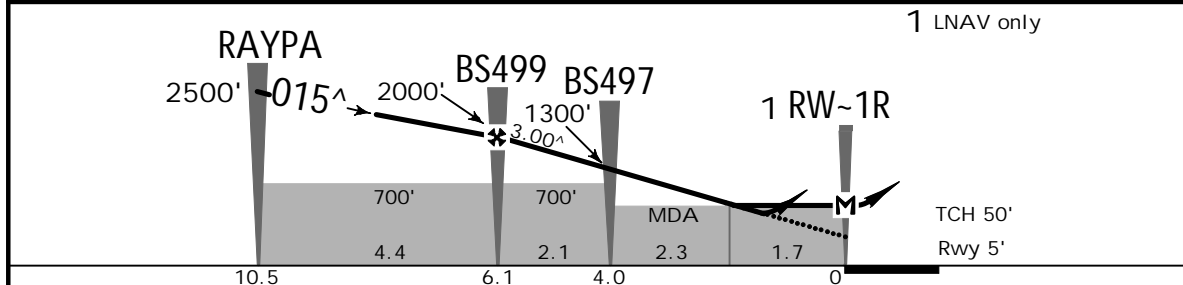

Gnd speed-Kts	70	90	100	120	140	160	ALSF-II PAPI	1500'	on 015^ track	3000'	D → RENEX
Descent Angle	3.00^	372	478	531	637	743					
MAP at RW-1R											

PANS OPS	STRAIGHT-IN LANDING RWY 01R				CIRCLE-TO-LAND	
	LNNAV/VNAV DA(H)	ALS out	LNNAV MDA(H)	ALS out	Max Kts	MDA(H)
A	800m	1600m	600' (595')	1600m	100	800' (795')-1600m
B	1600m	2400m	600' (595')	2400m	135	800' (795')-2000m
C	1600m	2400m	600' (595')	2400m	180	900' (895')-4400m
D	2000m	2800m	600' (595')	2800m	205	900' (895')-4800m

VTBS/BKK
SUVARNABHUMI INTL

JEPPESEN
1 OCT 21 (22-3) Eff. 7.Oct.

BANGKOK, THAILAND
RNP Rwy 19L

D-ATIS Arrival	SUVARNABHUMI Arrival (R)		BANGKOK Approach (R)			SUVARNABHUMI Tower		Ground		
	133.6	126.3	121.1	119.1	120.3	122.35	Rwy 01L/19R	Rwy 01R/19L	West Apron	Main Apron
RNAV	Final Apch Crs		BS599		LNAV/VNAV DA(H)		Apt Elev 5'			
	195 [^]		2000' (1995')		600' (595')		Rwy 5'			
MISSED APCH: Climb to 1500' on track 195 [^] , then climbing turn LEFT direct to LASON at 3000' and hold or as directed by ATC. If unable to reach 3000' at LASON, continue climb in the holding pattern. No turn before MAP. Speed restricted to MAX 210 KT until after turn.										<p>MSA ARP</p>
RNP Apch		Alt Set: hPa		Rwy Elev: 0 hPa		Trans level: FL 130		Trans alt: 11000'		
Baro-VNAV not authorized below 15 [^] C.										



NM to NEXT WP	2.1	3.0	4.0	5.0	6.0	BS599
ALTITUDE	730'	1005'	1320'	1635'	1950'	2000'

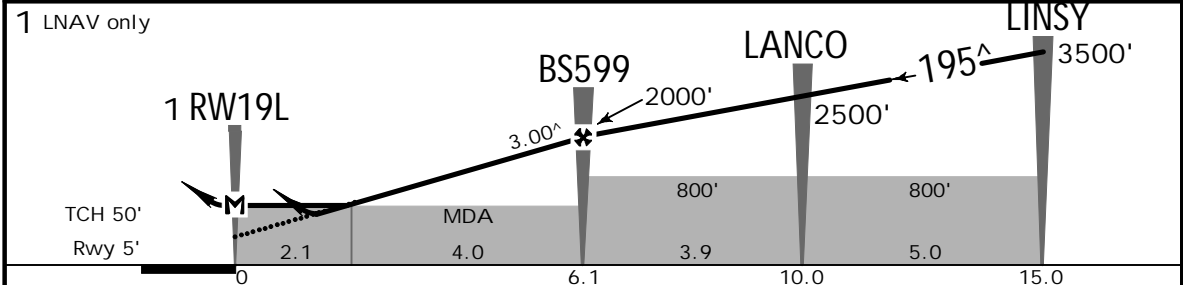

Gnd speed-Kts	70	90	100	120	140	160	ALSF-II PAPI 1500' ↑ on 195 [^] track 3000' LT → LASON
Descent Angle	3.00 [^]	372	478	531	637	849	
MAP at RW19L							

PANS OPS	STRAIGHT-IN LANDING RWY 19L				Max Kts	CIRCLE-TO-LAND	
	LNAV/VNAV DA(H) 600' (595')		LNAV MDA(H) 730' (725')			MDA(H)	
	ALS out	ALS out	ALS out	ALS out	100	800' (795')-1600m	
A	800m	1600m	800m	1600m	100	800' (795')-1600m	
B					135	800' (795')-2000m	
C	1600m	2400m	2400m	3200m	180	900' (895')-4400m	
D	2000m	2800m	2800m	3600m	205	900' (895')-4800m	

VTBS/BKK
SUVARNABHUMI INTL

JEPPESEN
1 OCT 21 (22-4) .Eff.7.Oct.

BANGKOK, THAILAND
RNP Rwy 19R

D-ATIS Arrival 133.6	SUVARNABHUMI Arrival (R) 126.3 121.1	BANGKOK Approach (R) 119.1 120.3 122.35 124.35 125.2 128.95			SUVARNABHUMI Tower Rwy 01L/19R Rwy 01R/19L 119.0 118.2		Ground West Apron Main Apron East Apron 121.95 121.75 121.65				
RNAV	Final Apch Crs 195^	BS588 2000' (1995')	LNAV/VNAV DA(H) 600' (595')	Apt Elev 5' Rwy 5'							
MISSED APCH: Climb to 1500' on track 195^, then climbing turn RIGHT direct to RIPS0 at 3000' and hold or as directed by ATC. If unable to reach 3000' at RIPS0, continue climb in the holding pattern. No turn before MAP. Speed restricted to MAX 210 KT until after turn.											
RNP Apch	Alt Set: hPa	Rwy Elev: 0 hPa	Trans level: FL 130	Trans alt: 11000'						MSA ARP	
Baro-VNAV not authorized below 15°C.											

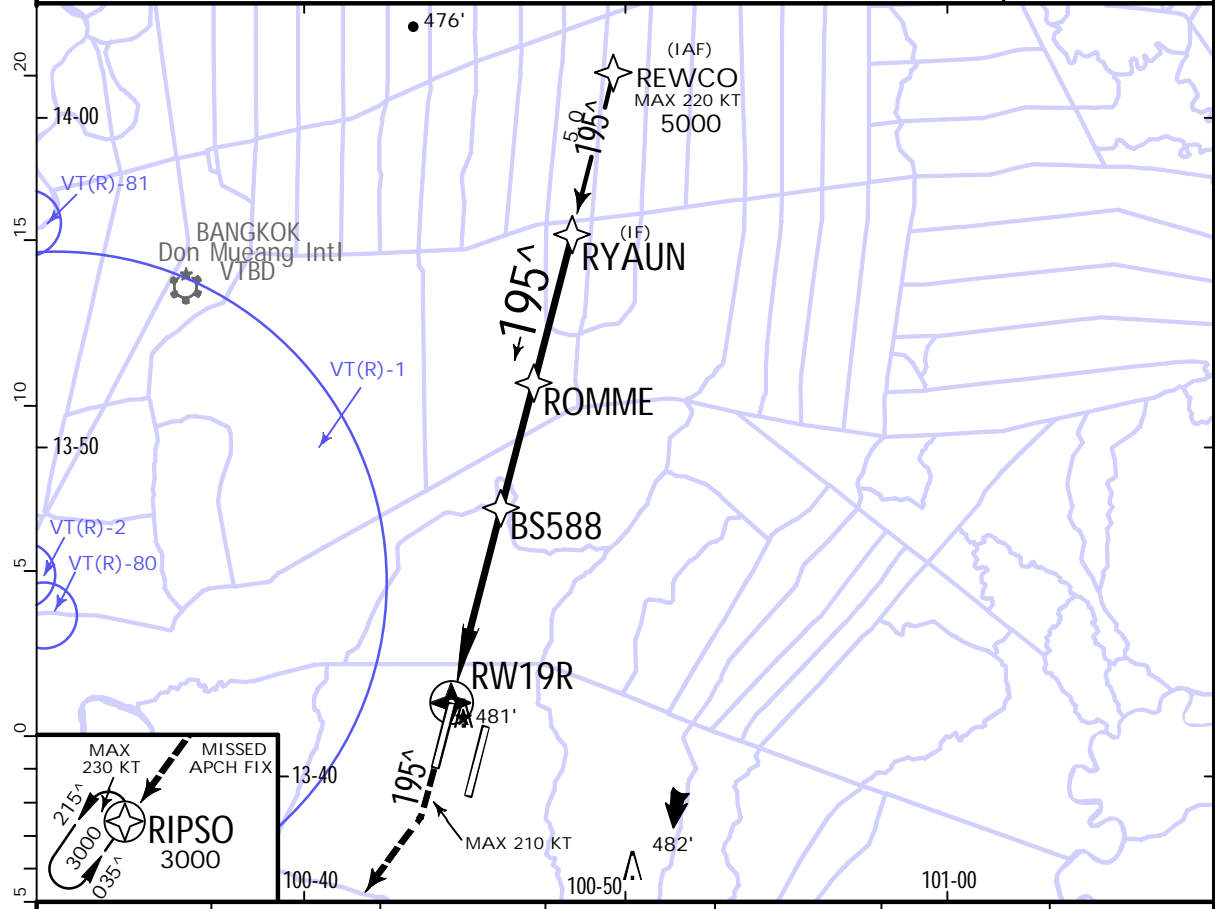

NM to NEXT WPT	2.1	3.0	4.0	5.0	6.0	BS588
ALTITUDE	730'	1005'	1320'	1635'	1950'	2000'

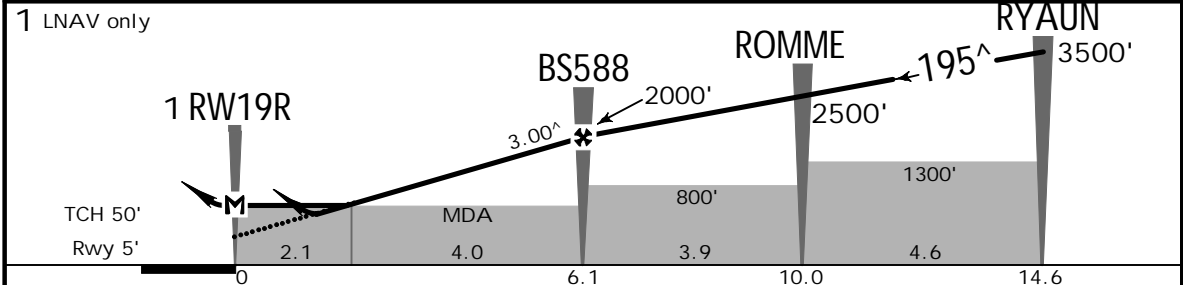

Gnd speed-Kts	70	90	100	120	140	160	ALSF-II PAPI	1500'	195^ on track	3000'	D → RIPS0
Descent Angle	3.00^	372	478	531	637	849					
MAP at RW19R											

PANS OPS	STRAIGHT-IN LANDING RWY 19R				Max Kts	CIRCLE-TO-LAND	
	LNAV/VNAV DA(H) 600' (595')	ALS out	LNAV MDA(H) 730' (725')	ALS out		MDA(H)	
A	800m	1600m	800m	1600m	100	800' (795')-1600m	
B					135	800' (795')-2000m	
C	1600m	2400m	2400m	3200m	180	900' (895')-4400m	
D	2000m	2800m	2800m	3600m	205	900' (895')-4800m	

CHANGES: Procedure title.

VTBS/BKK

SUVARNABHUMI INTL

JEPPESSEN
19 FEB 21 (23-1)

BANGKOK, THAILAND

VOR Rwy 01L

D-ATIS Arrival	SUVARNABHUMI Arrival (R)	BANGKOK Approach (R)			SUVARNABHUMI Tower		Ground		
133.6	126.3 121.1	119.1	120.3	122.35	Rwy 01L/19R	Rwy 01R/19L	West Apron	Main Apron	East Apron
		124.35	125.2	128.95	119.0	118.2	121.95	121.75	121.65

BRIEFING STRIP™

VOR SVB 111.4	Final Apch Crs 015^	LEVIN 2000' (1995')	MDA(H) 600' (595')	Apt Elev 5' Rwy 5'
-------------------------	-------------------------------	-------------------------------	------------------------------	-----------------------

MISSED APCH: Climb straight ahead to 3000' within D16.0 SVB VOR, then turn RIGHT with IAS not above 230 kt to RATLE and hold, or as directed by ATC.

Alt Set: hPa Rwy Elev: 0 hPa Trans level: FL 130 Trans alt: 11000'

In Case of Radar Failure: Aircraft will be cleared to BKK VOR then transition to LEVIN to carry out the VOR approach.

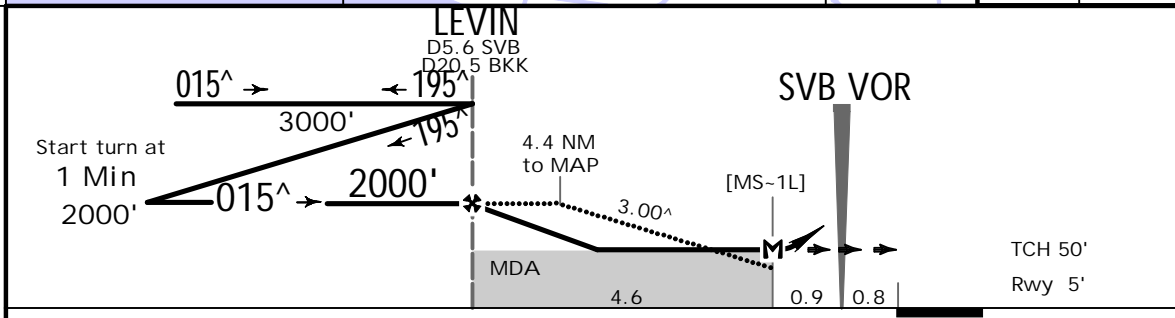
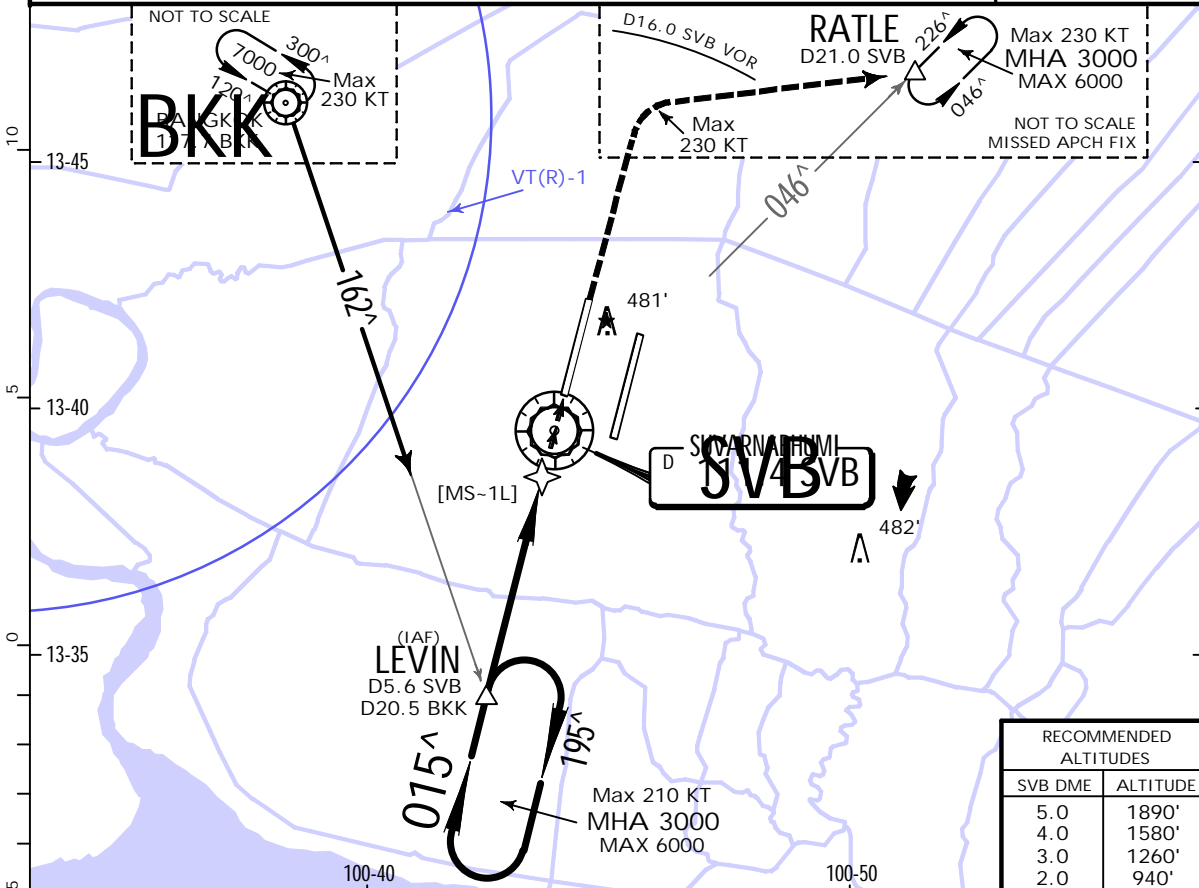
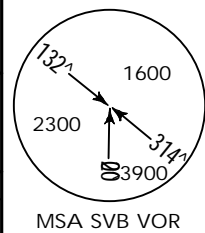

Gnd speed-Kts	70	90	100	120	140	160	ALSIF-II PAPI	3000' within SVB	RT	RATLE	
Descent Angle	3.00^	372	478	531	637	743					849
FAF to MAP	4.6	3:57	3:04	2:46	2:18	1:58					1:43

STRAIGHT-IN LANDING RWY 01L			CIRCLE-TO-LAND		
MDA(H) 600' (595')			MDA(H)		
ALS out			Max Kts		
A			100	800' (795') - 3200m	
B			135		
C	2400m	3200m	180	900' (895') - 4400m	
D			205	900' (895') - 4800m	

PANS OPS

CHANGES: Missed approach.

JEPPESSEN, 2010, 2021. ALL RIGHTS RESERVED.

VTBS/BKK
SUVARNABHUMI INTL

JEPPESEN
19 FEB 21 (23-2)

BANGKOK, THAILAND
VOR Rwy 19R

D-ATIS Arrival 133.6	SUVARNABHUMI Arrival (R) 126.3 121.1	BANGKOK Approach (R) 119.1 120.3 122.35 124.35 125.2 128.95			SUVARNABHUMI Tower Rwy 01L/19R Rwy 01R/19L 119.0 118.2		Ground West Apron Main Apron East Apron 121.95 121.75 121.65		
VOR SVB 111.4	Final Apch Crs 195 [^]	ROBBY 2000' (1995')	MDA(H) 730' (725')	Apt Elev 5' Rwy 5'					
MISSED APCH: Climb straight ahead to 3000', then turn LEFT with IAS not above 230 kts to COBRA and hold, or as directed by ATC.									
Alt Set: hPa		Rwy Elev: 0 hPa		Trans level: FL 130		Trans alt: 11000'			
In Case of Radar Failure: Aircraft will be cleared to BKK VOR then transition to ROBBY to carry out the VOR approach.									

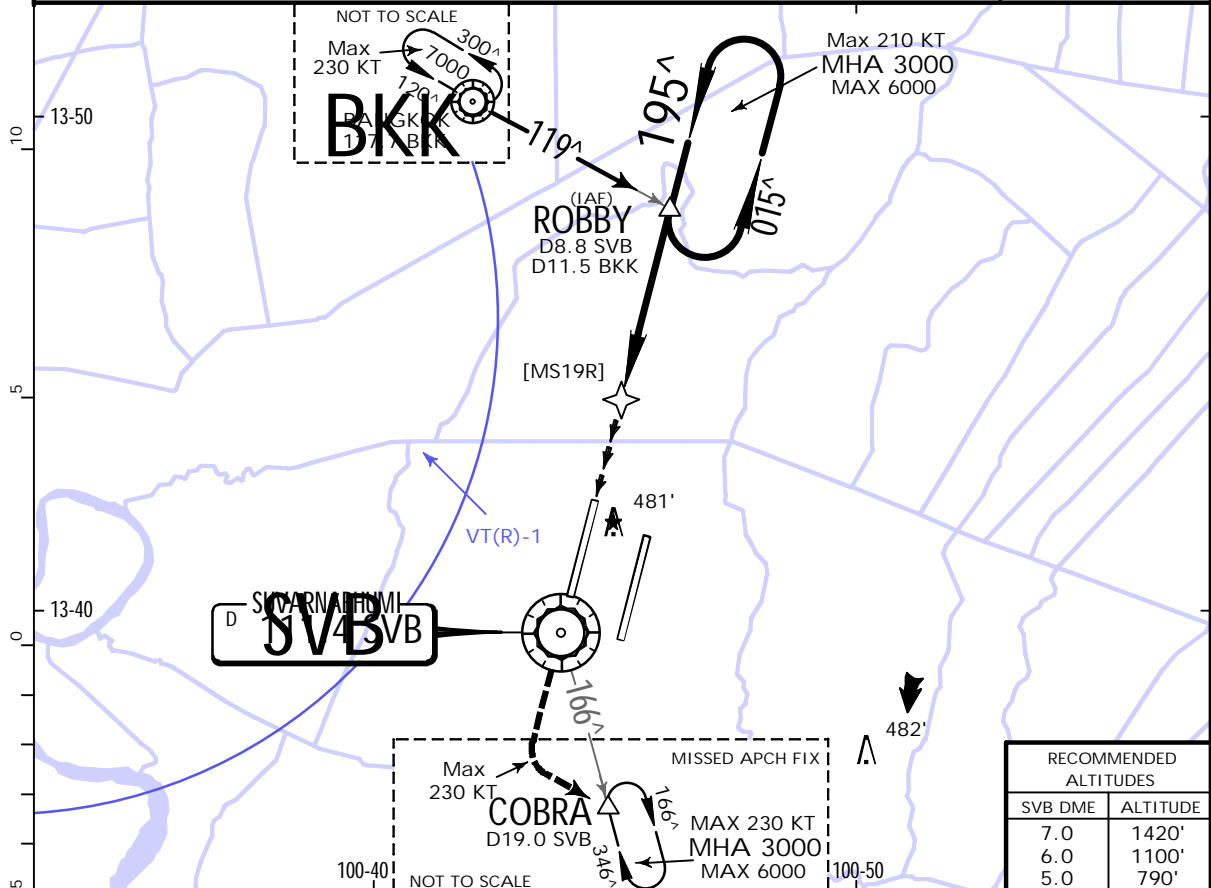

RECOMMENDED ALTITUDES	
SVB DME	ALTITUDE
7.0	1420'
6.0	1100'
5.0	790'

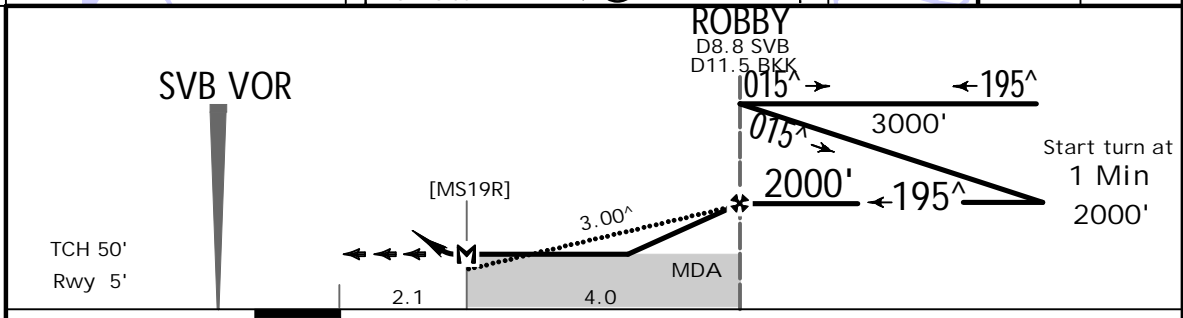

Gnd speed-Kts	70	90	100	120	140	160		3000' ↑ LT COBRA	
Descent angle	3.00 [^]	372	478	531	637	743			849
FAF to MAP	4.0	3:26	2:40	2:24	2:00	1:43			1:30

STRAIGHT-IN LANDING RWY 19R			CIRCLE-TO-LAND		
MDA(H) 730' (725')			MDA(H)		
ALS out			Max Kts		
A			100	800' (795') -3200m	
B	2400m	3200m	135		
C			180	900' (895') -4400m	
D	2800m	3600m	205	900' (895') -4800m	

PANS OPS

Chart changes since cycle 06-2023

ADD = added chart, REV = revised chart, DEL = deleted chart.

ACT PROCEDURE IDENT

INDEX

REV DATE

EFF DATE

BANGKOK, (SUARNABHUMI INTL - VTBS)

TERMINAL CHART CHANGE NOTICES

No Chart Change Notices for Airport VTBS